

# **Enactive Architecture**

**Considering the Role of  
Architectural Movement in  
Building Cognition.**

**Hugo Mulder**

IT UNIVERSITY OF COPENHAGEN



# Enactive Architecture

## Considering the Role of Architectural Movement in Building Cognition.

Doctoral Thesis by Hugo Mulder

Supervisor: Kjell Yngve Petersen

Submitted: July 2018

This research was supported in part by a grant from Arup.

**ARUP**

IT UNIVERSITY OF COPENHAGEN

# Table of Contents

	Abstract	4
	Resumé	6
<b>1.</b>	<b>Introduction: Move, Think, Act</b>	<b>8</b>
1.1	Research Approach	15
1.2	Structure of the Thesis	18
<b>2.</b>	<b>Start and Direction</b>	<b>20</b>
2.1	Cognitive Built Environment	23
	2.1.1. Intelligence in Design	24
	2.1.2. Artificial Intelligence in the Built Environment	25
	2.1.3. Junctures	28
2.2	From Cognitivism to Enactivism	36
	2.2.1. Three Problems in AI	37
	2.2.2. Three problems in Philosophy of Mind	38
	2.2.3. Enactivism	45
2.3	Dynamic Built Environment	54
	2.3.1. Human Movement	55
	2.3.2. Representation of Movement	56
	2.3.3. Design and Virtual Movement	57
	2.3.4. Actual Movement	63
	2.3.5. Identifying Structurised Movement	71
2.4	Taking stock	78

<b>3.</b>	<b>Prototyping</b>	<b>82</b>
3.1.	Research by Prototyping	85
3.1.1.	The Research Prototype as a Tool for Thinking	86
3.1.2.	Design Drivers	89
3.2.	Process Description	93
3.2.1.	Vertical slats	94
3.2.2.	Emergence	95
3.2.3.	Mobile Architecture	98
3.2.4.	Bending and Twisting	98
3.2.5.	Two Types of Movement	101
3.2.6.	Transparency	102
3.2.7.	Assembly	108
3.3.	Associated Hypomnesic Milieu	126
3.3.1.	Mnemotechniques and Literal Annotation	127
3.3.2.	Stepping Stone	128
3.3.3.	Digitisation of Fabrication	128
3.3.4.	Communication	130
3.4.	Prototyping: Review	131
<b>4.</b>	<b>Nine Works</b>	<b>136</b>
4.1	329 prepared dc-motors, cotton balls, toluene tank (2013)	142
4.2	Aegis Hyposurface (2001)	152
4.3	Wacoal-Riccar Pavilion (1970)	162
4.4	Maison à Bordeaux (1998)	172
4.5	Blur Building (2002)	182
4.6	Institut du Monde Arabe: South Facade (1987)	192
4.7	Spazio elastico (1959)	200
4.8	RV (Room Vehicle) House Prototype (2012)	208
4.9	Envir( )nment (2017)	220
4.10	Enactive Works	230
<b>5.</b>	<b>Moving On</b>	<b>236</b>
	<b>References</b>	<b>249</b>
	<b>Figures</b>	<b>267</b>
	<b>Acknowledgements</b>	<b>277</b>

# Abstract

The built environment is increasingly reliant on information technology at all stages of its life cycle. Design is informed by large data sets and conducted with digital design tools. Design documentation in *building information models* (BIM) supports construction and during the operational phase of buildings, artificial intelligence in *building management systems* (BMS) optimises the building's performance. This infusion with information technology has led to notions of smart, intelligent and cognitive buildings that adapt to their users' needs and enhance sustainable building performance.

However, the use of artificial intelligence to operate a building has a limited effect on the overall building design. This is not surprising given that intelligence itself is an abstract notion, whereas building design deals with concrete aspects such as a building's materiality, geometry, and organisation. This thesis proposes a new theoretical position on artificial intelligence in buildings, based on theories of enactive cognition that have roots in 20<sup>th</sup> century phenomenology and in the development of embodied robotics. Based on the researcher's past experience as a design engineer of some of the world's most complex movable building structures, the specific lens of kinetic architecture is chosen for investigating this position.

Navigating the physical forces that drive and constrain architectural motion through an active process of design and making has yielded the methods for engaging theoretically with the dynamics of cognition. The tools of engagement in this research are organised as a triptych of (1) scholarly involvement with the literature, (2) the design and making of a speculative research prototype, and (3) the descriptive analysis of historic and recent works of architecture and art.

The research is placed in a context referred to as the *cognitive built environment*—a collection of ideas about memory, perception, and intelligence and their technological implementation in the hardware that forms the built environment. As a counterpoint to forms of generic artificial cognitive abilities, the research traces a constructive and directed path through the literature in order to establish a notion of highly specific building intelligence that is underpinned by a building's physical manifestation and its capacity for movement. Two vectors are outlined to work as productive forces in this research. The first is a position that is taken in enactive cognition, based on the concepts of coupling, acting out, and exteriorisation. The second is a set of qualifiers brought together to identify *structured movement*—a form of essential architectural movement that is intentional, actual, and beyond utility.

A design process has been undertaken that responds to the speculative question: What if a building was made of movement? By making movement the central concern for the design and making of an architectural installation, the work has become an investigative filter that explores the capacity of architectural

movement to create a sense of space. This prototyping as a design process in a research context instrumentalises the prototype for enabling a particular way of thinking. The process of design and making has evolved and particularised the vectors of enaction and structured movement, while the physical manifestation of the prototype served as a technological externalisation of memory. This externalisation is framed as a *hypomnesic milieu* that structures thought by accommodating memory aids and stepping stones, through a process of *grammatisation*, and by enabling communication.

Nine works of art and architecture have been analysed that exemplify, each in its own way, how movement can be constitutive of architecture. In describing these nine works, a rich understanding is developed of movement in architecture and how it brings about enactive cognitive abilities. Conforming to the qualifiers for structured movement, the works selected are *329 prepared dc-motors, cotton balls, toluene tank* (2013), *Aegis Hyposurface* (1999), *Wacoal-Riccar Pavilion* (1970), *Maison à Bordeaux* (1998), *Blur Building* (2002), the southern facade of the *Institut du Monde Arabe* (1987), *Spazio elastico* (1959), *Room Vehicle* (2012) and *Envir(onnement)* (2017). The last work was conducted as part of this research.

Through a combination of case study analysis and research by design, a framework is presented that interprets movement in buildings as a critical aspect of cognition. The contribution challenges current ideas of how IT infrastructures, services, and building functionality in intelligent buildings can be understood, and presents a complementary view that promotes a form of intelligence that is specific for buildings. The implication is that artificial intelligence becomes concretised as a tangible aspect that can be added to the palette of engineers and architects involved in integrative design of buildings.

# Resumé

Det byggede miljø forlader sig i stigende grad på informationsteknologi inden for samtlige stadier af dets livscyklus. Designprocessen baseres på store datasæt og finder sted ved hjælp af digitale værktøjer. Designdokumentation med Bygnings Informations Modeller (BIM) understøtter konstruktionsfasen og i den operationelle fase optimerer kunstig intelligens, i form af Bygnings Management Systemer (BMS), bygningens præstation. Den gennemtrængende rolle informationsteknologi er begyndt at spille i arkitektur har ført til begreber såsom smarte, intelligente og kognitive bygninger, der tilpasser sig deres brugeres behov og forbedrer bæredygtig drift.

Brugen af kunstig intelligens til bygningsdrift har dog haft en begrænset indflydelse på bygningers overordnede design. Dette er ikke overraskende, da intelligens i sig selv er et abstrakt begreb, og bygningsdesign beskæftiger sig med konkrete aspekter såsom en bygnings materialitet, geometri og organisering. Denne afhandling foreslår en ny teoretiske position i forhold til kunstig intelligens i bygninger baseret på teorier om *enactive cognition*, der har rødder i det 20. århundredes fænomenologi og udviklingen af *embodied intelligence* indenfor robotteknologi. Med udgangspunkt i min baggrund som designingeniør på nogle af verdens mest komplekse bevægelige bygninger, er kinetisk arkitektur valgt som den konkrete linse hvorigennem denne position undersøges.

Erfaringer med de fysiske kræfter, der driver og indskrænker arkitektonisk bevægelse, i en aktiv praksis-baseret designproces har affødt metoderne til en teoretisk behandling af kognitionens dynamikker. Værktøjerne hertil er organiseret som et triptykon, der består af (1) videnskabelig behandling af faglitteraturen, (2) design og fremstilling af en spekulativ forsknings-prototype og (3) beskrivende analyse af historiske og samtidige arkitektur- og kunstværker.

Forskningen placerer sig inden for hvad, der refereres til som det kognitive byggede miljø—en samling af idéer om hukommelse, perception og intelligens og deres teknologiske implementering i den "hardware", der udgør det byggede miljø. Som et kontrapunkt til begreber om generelle kunstige kognitive evner, optegner forskningen en konstruktiv og dirigeret sti gennem litteraturen, for at etablere idéen om en særegen bygningsintelligens, der understøttes af en bygnings fysiske manifestation og dens evne til at bevæge sig. To vektorer skitseres, der agerer som generative kræfter herfor. Den første position er funderet i *enactive cognition* og baserer sig på begreberne om *coupling*, *acting out* og *exteriorisation*. Den anden består af et sæt bestemmende ord, der er sammenbragt for at identificere *structured movement*—en essentiel form for arkitektonisk bevægelse, der er intenderet, virkelig og hinsides nytte.

En designproces er gennemført, der responderer på det spekulative spørgsmål: Hvad nu hvis en bygning bestod af bevægelse? I kraft af at bevægelse gøres til det centrale anliggende for designet



og konstruktionen af en arkitektonisk installation har dette arbejde fungeret som et undersøgende filter, der udforsker arkitektonisk bevægelses evne til at skabe rumfølelse. Denne prototypeudvikling som designproces i forskningsregi instrumentaliserer prototypen for at muliggøre en bestemt tænkning. Design- og konstruktionsprocesserne har udfoldet og konkretiseret vektorerne *enaction* og *structured movement*, alt imens prototypens fysiske manifestation tjener som en eksternalisering af hukommelse. Denne eksternalisering rammesættes som et hypomnesisk milieu, der strukturerer tænkning ved at indpasse hukommelseshjælpemidler og -trædesten, gennem en grammatiserings-process og ved at muliggøre kommunikation.

Ni kunstværker og arkitektoniske værker analyseres, der hver især eksemplificerer hvordan bevægelse kan være essentiel for arkitektur. Gennem beskrivelserne af disse udvikles en righoldig forståelse af bevægelse i arkitektur og hvordan denne afstedkommer enaktive kognitive egenskaber. I overensstemmelse med de bestemmende ord for *structured movement* er følgende værker valgt som analyseobjekter: *329 prepared dc-motors, cotton balls, toluene tank* (2013), *Aegis Hyposurface* (1999), *Wacoal-Riccar Pavilion* (1970), *Maison à Bordeaux* (1998), *Blur Building* (2002), den sydvendte facade af *Institut du Monde Arabe* (1987), *Spazio elastico* (1959), *Room Vehicle* (2012) og *EnvirOnment* (2017). Sidstnævnte værk er skabt som en del af denne afhandling.

Gennem en kombination af analytiske case-studier og designforskning (research by design) præsenteres et metodeapparat, der fortolker bevægelse i bygninger som et kritisk aspekt af kognition. Forskningsbidraget udfordrer samtidige idéer om hvordan IT-infrastrukturer, services og bygningsfunktionalitet i intelligente bygninger kan forstås og præsenterer et komplementært synspunkt, der plæderer for en type intelligens, der er specifik for bygninger. Implikationerne heraf er, at kunstig intelligens konkretiseres som et håndgribeligt aspekt, der kan føjes til ingeniører og arkitekters repertoire i integrative bygningsdesign.

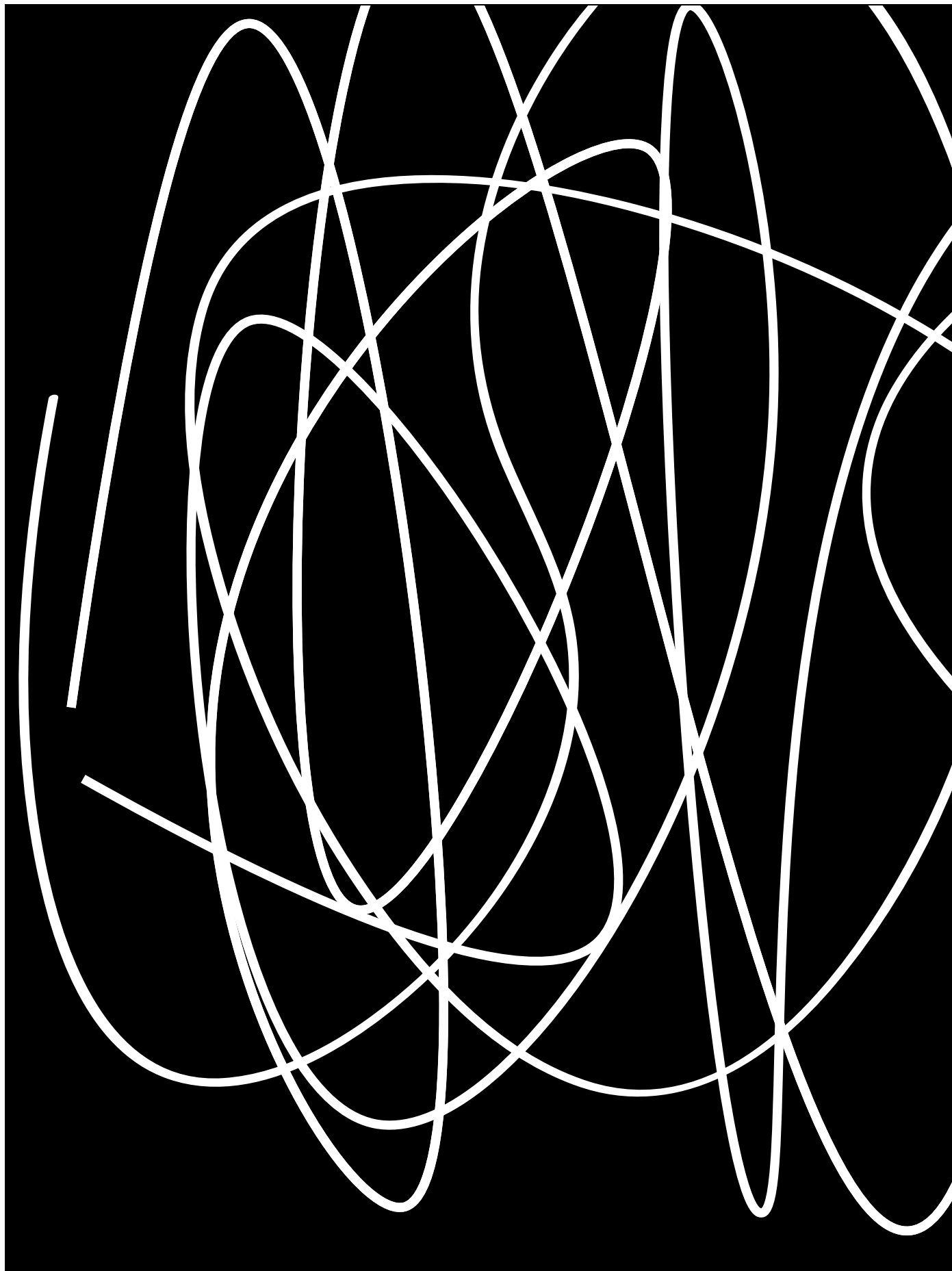

**1.**

**Introduction:**

**Move, Think, Act**

This thesis investigates the capacity for cognitive agency of architecture, promoted by the impact of the digitisation of the built environment. The research employs the lens of actual movement of architecture to establish an understanding of cognition that is specific to buildings. It examines architectural space that is defined by movement and speculates about movement that is constitutive of architecture, in order to describe architecture as *enactive*.



1.1 Constant Nieuwenhuys, Mobiel Ladder Labyrinth (1967). Constant's New Babylon was a vision for a network of future cities that were frameworks for change.

Movement of architecture has been a personal fascination for many years, and has been the subject of most of my professional life as an engineer with Arup. Movement in the built environment is typically the domain of mechanical and structural engineers designing movable bridges, sluices or industrial cranes. However, in my role at Arup, I designed and specified movable building parts, including the mechanisms that would drive them into motion.

Movement that transforms buildings has long been, and still is, an oddity. It has been the realm of speculation about possible futures for the built environment (figure 1.1), but relatively few buildings have been realised with the capacity for transformation (figure 1.2). This is perhaps no surprise, given the additional complexity that movable elements bring to the design and realisation of a building. It requires the need for yet another specialist and demands an ongoing commitment to maintenance. But when movement does successfully become part of architecture, and when it transcends the state of merely being useful, it lifts the architecture to another dimension. The ability to take on different states, the gracious change of form, or the rhythmic shifts in patterns—actualise a potential of architecture for structural change, which can be so significant that it becomes a defining characteristic. We could say that such architecture acts itself out.

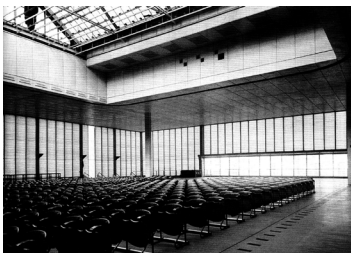

1.2 Jean Prouvé, Marcel Lods, Eugène Beaudouin, Vladimir Bodiansky; Maison du Peuple in Clichy. The building featured a retractable roof, a movable curtain wall, and an ingenious retractable floor system.

A development I have found myself in the midst of, perhaps inescapably, is that of the digitisation of the design process, of the processes that lead design to production, and of the physical manifestation of architecture. The particular aspect that I found myself drawn to was the boundary between the digital and physical realms, which has become increasingly blurred, perhaps even irrelevant to some. This aspect has been the topic of a transdisciplinary exploration over a number of years that I have been especially close to as a participant and organiser of several Smartgeometry conferences and workshops. As a meeting place of academics and practitioners, Smartgeometry is especially attuned to the currents that motivate both expert practices, establishing a condition of productive urgency. This was the case also when Smartgeometry workshops began to require the alignment of computational design with digital fabrication, from 2010 onwards, and the question of the digital–physical boundary became particularly pertinent. Not only would this alignment address the gap between the peculiarities of physical reality and the digital model world, but it would lead to a fusion of digital infrastructures with the traditional materiality of architecture. Initially at Smartgeometry, the fusion tended to be directed digitally inwards, informing the design process. But progressively it would facilitate the continuation into architecture of the transformative capacities of digital technology.

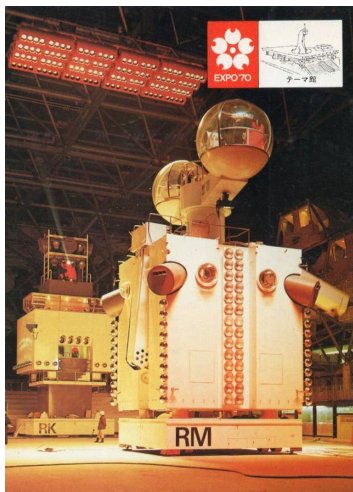

1.3 Arata Isozaki, Deme and Deku performing robots. The robots provided a stage for human performers and housed a manned control room.

The digital continuation into architecture would also see the potential transfer of knowledge into a living building. Intimate knowledge about the operations of a building was traditionally locked in the design as a virtual potential for unfolding futures. But the digital persistence in the actual building would allow for this know-how to become available as a cognitive ability in the form of building intelligence. The promise of such highly specific building intelligence has been betrayed by a reality of ubiquitous general intelligence being implemented at unprecedented scale. Although ideas of intelligent buildings are nothing new, the ready availability of the algorithms and hardware to implement intelligence in our current times have spawned whole new industries. One aspect of this rapid roll-out is that it takes place in a fragmented fashion, and without much consideration for the architecture in which it is incorporated. Such unspecific digitisation of the built environment may lead us to regard intelligence of buildings in terms of generic computer networks.

This thesis chooses a different perspective and hypothesises that in terms of its intellectual abilities, it would be much more potent to regard the building as a robot. Not perhaps as literally as Arata Isozaki's giant robots Deme and Deku, that roamed the festival plaza of Expo '70 in Osaka (figure 1.3), but as part of the idea that a building's physical makeup, and the way it moves, are constitutive of its cognitive agency. An *enactive* view of cognition, as this might be called, allows us to address cognition in a way that is specific for each building and could therefore be seen as a contribution to the current trend of implementing more generic artificial intelligence in the built environment.

This specific view of how the building is cognitive is framed in this thesis using the concepts of *coupling* and *acting out* that concern the moving building and its relation with its environment. The enactive view also lets us deal directly with the aspect of occupancy, which marks a critical difference between most robots and buildings. The concept of *exteriorisation*, understood within the enactive framework, allows us to describe the building as technically related to the occupant, and in that capacity, to mediate the relation between occupant and environment.

## Why this research now?

The need and the urge to conduct more research into movement of buildings is driven by a number of factors. To start, this research is only taken up by practitioners on a case-by-case basis. A personal observation while working as an engineer with architectural movement at Arup is that movable projects were often unique in the portfolio of the designing architects. This meant, in George Rickey's words, that the designs never quite left the explorative phase. Individual practices therefore would not get the chance to develop a refined language of movement. To use Hans Richter's term (Rickey, 1963; Selz, 1966), there has also been no *movement movement* in architecture, or a style that was characterised by movement so that architects could gradually build on the work of others. Where actual



1.4 soma, One Ocean Pavilion. 98 flexible louvers in the external facade open and close to control daylight influx.

movement did play a role in buildings, this has been to enhance capacities, for example towards adaptation, interaction, multi-function or sustainable operation—but movement, in those cases, was supportive and secondary to those other purposes.

In academia, movement of architecture is emerging as a primary research topic, and there are calls for further engagement. The exploration in architectural practice of movement as an abstract phenomenon is often hard to justify, given the other concerns an architectural design ought to address. But as Jane Burry observes (Burry, 2013), the static forces of gravity have been celebrated in architecture abundantly, why not the dynamic processes that influence our buildings just as much? And beyond the technical systems that enable movement in buildings, we should direct our attention to the conceptual dimension of change and the effects of time on the experience of architecture, according to Branko Kolarevic (Kolarevic & Parlac, 2015).

Research into movement seems opportune. A revival of the interest in movement of architecture is underway, after a previous high point in the 1960s and 1970s—drawing a parallel to kinetic art is almost unavoidable. The current wave of interest in architecture and art seems to be resulting in many more examples of movement being actually realised in buildings. Examples include the facade of One Ocean Pavilion by SOMA (2012) (figure 1.4), the rotating rooms of the Sharifi-ha House by Next Office (2014) (figure 1.5), and the movable platforms of Fondation d'Entreprise Galeries Lafayette by OMA (2018) (figure 1.6). This could potentially stem from the sophistication of the design and specification of movable elements, advances in building technology, and enhanced skills of specialist contractors. However, it is also likely to result from the perceived benefits of movement in relation to environmental concerns or to economic factors realised, for example, in multi-purpose buildings.



1.5 Next Office, Sharifi-ha House. Three rotating boxes give the interior an open or closed character.

The concern for cognition is equally timely and comes amid enormous strides in the advancement of machine learning, while the industries designing and constructing the built environment are only just coming to grips with its implications. If, as Bernard Stiegler claims, the human capacity for thought has evolved together with technology and relies fundamentally on exteriorisation, a design responsibility towards the occupant necessitates a critical position regarding building cognition. Because, as Keith Evan Green has suggested, the technology we inhabit inevitably becomes us (Green, 2016).

## Towards an Enactive Architecture?

From experience and personal interest, my selective perspective on architecture is one of movement. I am drawn to architectural and art works that display movement and I am mesmerised by the infinitude of ways in which movement manifests itself. And always, due to *déformation professionnelle*, I want to know how it works. My view of architecture is defined by movement.



1.6 OMA, Fondation d'Entreprise Galeries Lafayette. Four movable platforms allow for multiple configurations of the building.

Two questions emerged during the course of this research: Could architecture itself be defined by movement and could movement be so significant, that it would define the building it was part of? Of course, this would still largely be a matter of perspective, but in developing that perspective, a number of architectural and art projects emerged that seemed to feature movement of a special kind. It was as if by moving, and only by moving, these projects became what they were. These were works made of movement. Rather than evidencing movement of architecture, these works exemplified an architecture of movement.

With this understanding forming from revisiting existing work, the question arose whether the insights could be made productive and could be implemented. Would it be possible to design and make a prototype environment that was made of movement?

The questions I have become familiar with during my years in engineering design were *how to* questions: How to rotate with high accuracy a 90-m-diameter dome structure on a mountain top? How to make a 10-m pole sway elegantly and safely in the wind? The research exercise now asked a *what if* question: What if a building was not made of steel and concrete, but was made of movement? My subsequent response would be in the form of design and would again have a familiar form: How to make architecture of movement?

The concern with the primacy of movement presented a compelling parallel with the centrality of movement in the enactive view of cognition. The enactive view of cognition is part of a wider

discourse that takes issue with more traditional views that have shaped the artificial forms of cognition commonly used today. Enactivism presents an understanding of the active movements of an agent as constitutive of its cognitive functions and brings a certain specificity related to their physical make-up and their potential for movement. This led to the hypothetical postulation that the abstract concept of enactive cognition could be concretised in architecture through movement. In other words, could movement allow us to design with cognition? How would we approach such design? And what could the resulting outcome look like?



# 1.1 Research Approach



1.7 Lina Bo Bardi, *Cavaletes de Vidro* (glass easels).



1.8 Damien Newman, *Design Squiggle*.

1.9 Triple Squiggle.

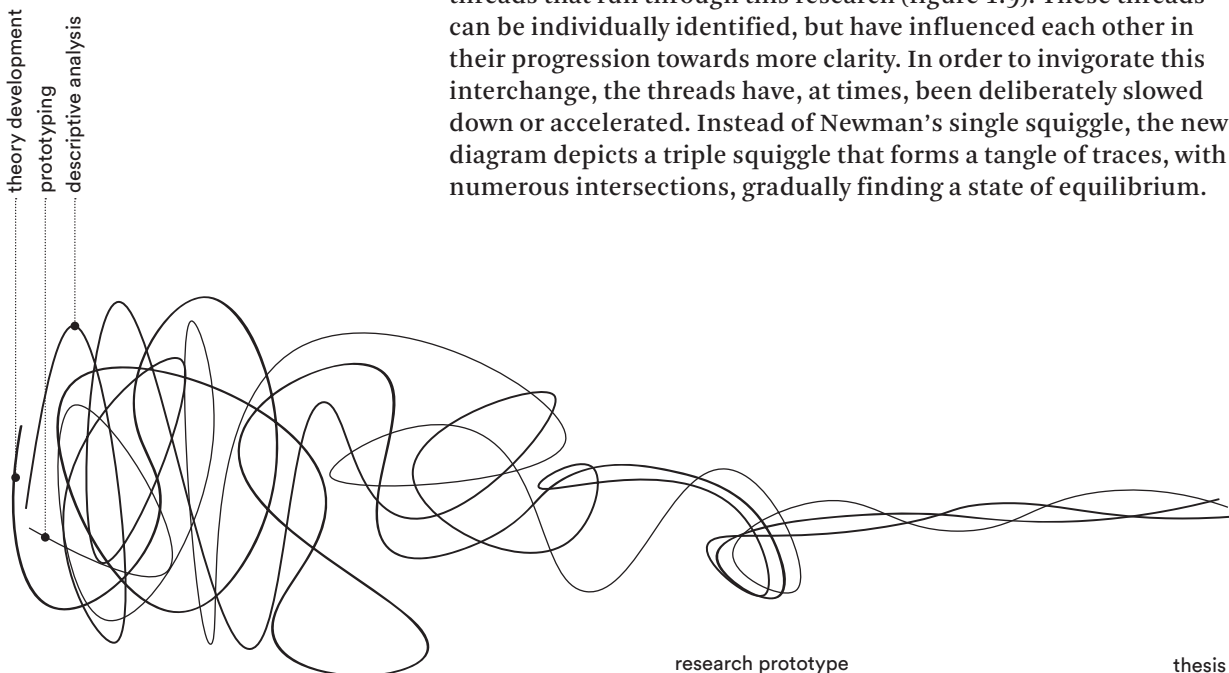

O tempo linear é uma invenção do ocidente, o tempo não é linear, é um maravilhoso emaranhado onde, a qualquer instante, podem ser escolhidos pontos e inventadas soluções, sem começo nem fim. Linear time is a Western invention, time is not linear, it is a marvellous tangle, where, at any moment, points can be selected and solutions invented, without beginning or end.

Lina Bo Bardi (1993, p. 327)

The main exhibition hall at the Museu de Arte de São Paulo (MASP) was conceived by Lina Bo Bardi as an open space where the collection was displayed on glass easels (figure 1.7). Visitors would be encouraged to wander unconstrained, taking in the works and making their own connections—the glass structures enabling endless perspectives.

Bo Bardi's exhibition design seems an appropriate metaphor for the design space where ideas, old and new, are combined in ever-changing ways. When I think of myself designing, I drift to orientate myself, taking in ideas, and progressively developing an ever-stronger interest and focus. My approach to this research has resembled my approach to design. The design process as the tracing of a path in unstructured territory is reflected in the diagram that Damien Newman drew to explain to his clients the inherent uncertainty that characterises especially the start of many design projects (figure 1.8). Various procedural models compete to be truthful depictions or structured guidance of the design process, but Newman's *Squiggle* resonates with my own design experience. Rather than explaining design as a sequence of stages, the diagram was found to be more effective in conveying a process that reaches clarity only late in the process (Newman, 2008).

I have adapted Newman's squiggle to take into account the three threads that run through this research (figure 1.9). These threads can be individually identified, but have influenced each other in their progression towards more clarity. In order to invigorate this interchange, the threads have, at times, been deliberately slowed down or accelerated. Instead of Newman's single squiggle, the new diagram depicts a triple squiggle that forms a tangle of traces, with numerous intersections, gradually finding a state of equilibrium.

Today, design is one of the many available approaches to academic research. Einstein famously wrote that “The whole of science is nothing more than a refinement of every day thinking” (1936). This could lead us to think of knowledge and its practices as shades along a spectrum. With the increasing variety of research methods and the recedence of the university as the exclusive facilitator of scientific research, it has become harder to pinpoint what makes knowledge common, applied, scientific, or academic, and what practices lead to any such knowledge.

The divergence from the rational approach to scientific research in the twentieth century can be related to various tendencies, one of which would be the sociological turn in the philosophy of science that was influenced by the work of Thomas Kuhn (Kroes, 1996; Kuhn, 1962). Kuhn argued that the acquisition of knowledge, and also the obtained knowledge itself, could be partly or wholly attributed to social phenomena, and not, as was generally assumed before, to a reasoned process alone. Along with his idea of scientific paradigms and the role of theory-dependence in scientific research, Kuhn proposed a theory of *incommensurability* that implied a rejection of a universal approach to research and its methods. Research from one paradigm to another would not necessarily share a common basis that would ultimately lead to an ever-refined world view. In its wake, Kuhn’s work also gave credence to the scientific status of fields such as sociology and the humanities, along with their varied practices. A research landscape now emerged in which research disciplines would be working with their own methods that would be appropriate for their particular type of research.

The study of design gained traction in the 1960s, notably through the Conference on Design Methods in London in 1962 followed by the initiation of the Design Research Society in 1966 (Design Research Society, 2017). Initially, the interest focused on how designers work, but about two decades later, the idea took hold that design as a research discipline could stand on its own, next to science and the humanities. An article by Bruce Archer in the first edition of *Design Studies* in 1979 made the point for such a third area that acknowledged “the existence of an approach to knowledge, and of a manner of knowing that is distinct from those of Science and the Humanities” (Archer, 1979). Nigel Cross developed such *designerly* knowing in a subsequent article as a discipline in which its practitioners “develop their subject in its own terms” (Cross, 1982). This presented the possibility of conducting research through design, design not being the subject of study, but the primary methodology. As practices of “deeds not words”, Christopher Frayling wrote about both art and design in a similar fashion, by distinguishing research into art and design, research for art and design and research through art and design (Frayling, 1993). He made the critical note that research through art and design does not equal the normal art and design practice, but should aim to achieve knowledge and understanding. Thus, its primary goal should be the development of knowledge, and not the art or design in itself. The alignment of European universities in the European Higher Education Area (EHEA) through the Bologna Accords has catalysed this thinking about design and art as forms of research. The three-tiered structure (Bachelor, Master, PhD)

and mechanisms for accreditation have forced many schools of art, design and architecture in the EHEA to report in terms of their research output and have cemented the status of the design and art disciplines as vehicles for academic research (Verbeke, 2013).

In the essay *Design Research: The First 500 Years*, Jonathan Hill writes that the methods now employed to engage in formal academic research through architectural design have been around from the fifteenth century (Hill, 2013). He sets out four understandings of design that highlight various facets of the architectural discipline. The first is also the earliest, tracing back the origin of the word *design* to the Italian *disegno*, which means drawing. It was during the Italian Renaissance that drawings came to be truthful depictions of the world, fuelled by Brunelleschi's development of graphical perspective. *Disegno* brought the previously material arts of architecture, painting and sculpture to the level of ideas, which gave them much higher status. The second understanding is related to the *picturesque* of the 18th century. As Hill explains, the picturesque recognised the subjective reality as initially posited by philosopher John Locke. Design could now "draw forth an idea that was provisional, changeable and dependent on experience at conception, production and reception" (p. 20). A third notion of design is associated with the industrialisation of the late 18th century, where design became linked to utility. Now that design had become associated with industrial mass production, and no longer with higher ideas, the fine arts of sculpting and painting (but not architecture) disassociated themselves from design. The fourth understanding of design emerges from the contemporary hybrid practice where computer-aided design and manufacturing are closely linked. The designer and maker have (again) become the same person who combines intellectual and manual labour, personifying the feedback between these modes of operation.

Architectural design, in Hill's analysis, is a mix of using drawing to represent ideas, of developing provisional ideas to be subjected to experience, of functional problem solving, and of design and making. The explorative practice of architecture, Hill suggests, is performed as a triptych: "Studying the history of architecture since the Italian Renaissance, it is evident that researching, testing and questioning the limits of architecture occur through drawing and writing as well as building" (p. 19). The three aspects of drawing, writing and building are reflected in this research as illustrated in the diagram at the start of this section, where the squiggles represent the development of theory, descriptive analysis of architectural works and the process of prototyping.

## 1.2 Structure of the Thesis

The triple squiggle represents the three research threads— theory development, descriptive analysis, and prototyping. This arrangement is more or less reflected in the structure of the three core chapters of the thesis, but inevitably, and intentionally, the chapters do not strictly adhere to the threads themselves. The threads can be seen as depicting the contours of the areas covered in the chapters.

Chapter 2, *Start and Direction* demarcates the context to which this thesis responds and defines two vectors that set up the theoretical direction of the research. The context, and starting point of the vectors, is the notion that the built environment has some form of cognitive agency. The context unpacks a number of different ways in which this notion has influenced how we think about buildings that are said to be smart or intelligent.

The first vector that expresses a direction departing from the established starting point is a particular view on cognition: enactivism. This view has a history that is rooted in the philosophy of mind and in robotics. As subscribers to the enactive view do not agree on all points, a position is specified in chapter 2 and loaded for use in the later chapters.

The second vector points at the phenomenon of movement in architecture and establishes qualifiers for movement that is constitutive of architecture and therefore non-reducible. This specific movement is referred to as *structured movement*. The concept of structured movement has been sharpened, and reoccurs in the following chapters.

Chapter 3, *Prototyping* presents the creation of a research prototype that was employed as a tool for thinking throughout the research process. The prototyping process is situated as a speculative design exercise—including the fabrication of a physical installation—responding to the question: What if architecture was made of movement? The prototyping process advances the two directions set out in chapter 2.

In terms of the first vector, enactivism, the prototyping process is analysed as an enactive engagement with the physical materials that make up the prototype. In this understanding, the process exemplifies an *associated hypomnesic milieu*, a term used in Bernard Stiegler's theory of technological exteriorisation. The process can be said to turn on itself, because in being this hypomnesic milieu, it supports the progressive understanding of enactivism in kinetic architecture.

In terms of the second vector, movement, the clarification of the design's objectives and criteria, as well as working through subsequent design iterations, has helped identify and progress the qualifiers for demarcation of structured movement.

Chapter 4, Nine Works analyses nine works of art and architecture, including the research prototype. These works feature movement in a non-reducible way. The works are selected based on the qualifiers established and refined in the previous chapters. Although the works all share the specific qualities of structured movement, there is great variety in the manifestation of movement. Each work acts itself out in a specific way and is distinctly related to its environment. The analysis of the works leads to a rich set of descriptions of what can now be called an *enactive architecture*. Relating the works in different ways, the key aspects of enactivism as established in chapter 2 and developed in chapter 3, are made to advance an understanding of building cognition that relates occupant, environment, and building.

Chapter 5, Moving On, is the concluding chapter of this thesis. The chapter is organised as a series of questions around the theoretical position of enactive architecture. The chapter starts by analysing the agencies at work when observing and describing architectural movement and then addresses specifically the agency of representation as a comment on this work of research.

The questions that follow turn to the position of enactive architecture and its implications: What could enactive architecture look like and how do we go about designing it? These sections provide an outlook for future buildings and design practice based on the concepts and reference works covered in this thesis.

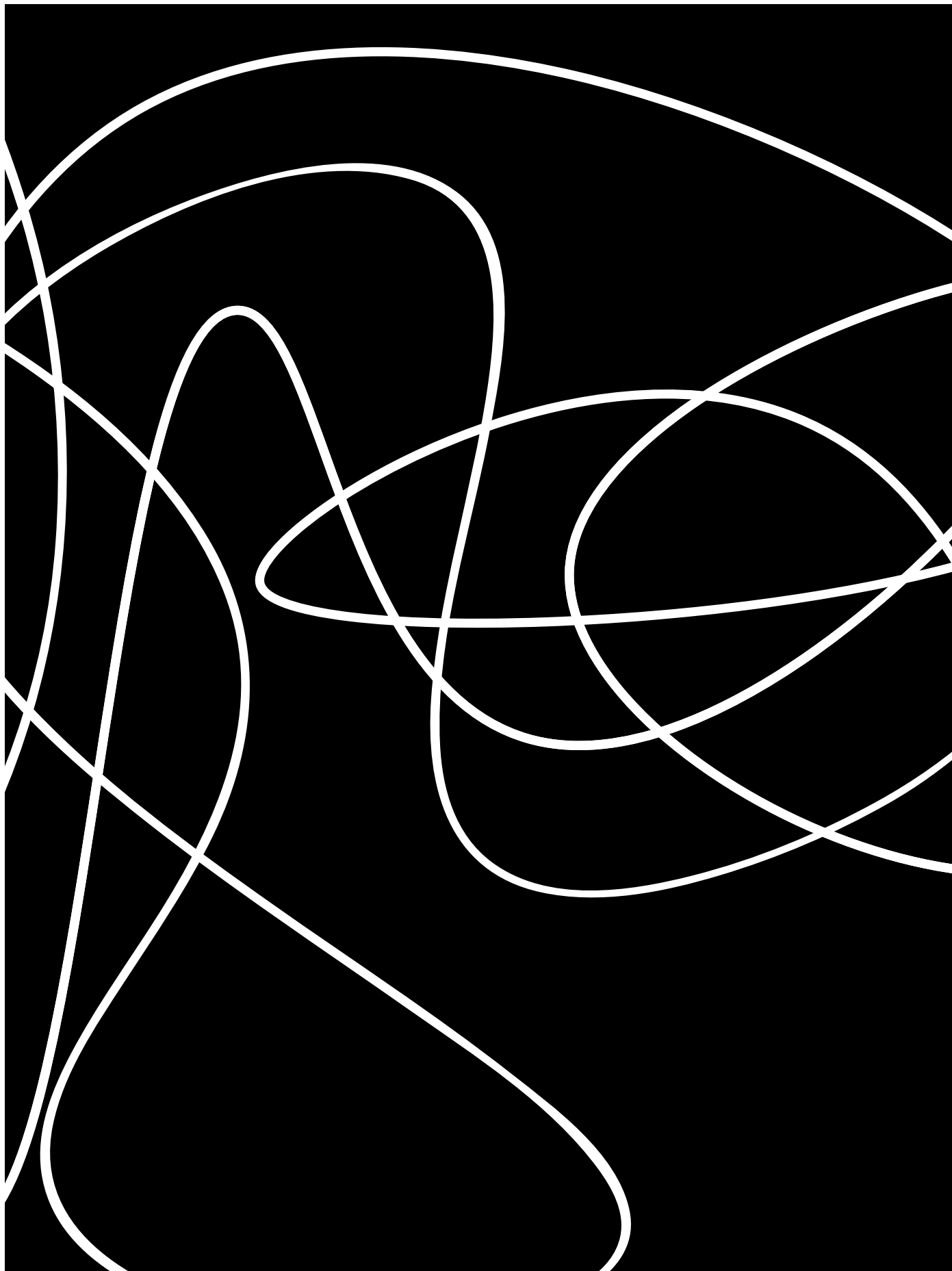

**2.**

# **Start and Direction**

This chapter sets up the springboard for the research in providing a context as a point of departure and a theoretical direction of investigation. This positioning comes in three sections. Section 2.1 describes the context to which this thesis responds. Sections 2.2 and 2.3 set out one vector each, providing directionality.

Section 2.1 discusses the context surrounding the notion of the *cognitive built environment*. A certain understanding of the built environment as having the capacity for cognition, underlies this notion. This section outlines five ways in which this capacity has been instantiated, looking at *classic AI*, *connectionism*, *cybernetics*, *embodied AI* and *swarm intelligence*. In all of these five ways, understandings of technological and natural cognition have influenced each other, implying both the building and the occupant.

Section 2.2 describes the first of two vectors, which leads towards an understanding of cognition that is referred to as *enactivism*. Enactivism is rooted in a phenomenal philosophical tradition, but also leans on advances in embodied robotics. The historical roots of enactivism are traced in this section and a position is described by selecting and interpreting three key aspects of the enactive view: *coupling*, *acting out*, and *exteriorisation*.

Section 2.3 describes the second vector, which specifies the particular manifestation of movement in architecture that this thesis primarily addresses. Movement has, in many ways, influenced architecture historically and some of the key influences are addressed in this section, some of them related to the realm of computation. The term employed for a type of movement that is constitutive of architecture is *structured movement*. This term is specified by three qualifiers that prescribe such movement to be *intentional*, *actual*, and *beyond utility*.



## 2.1 Cognitive Built Environment

The predominant understanding of buildings as being *cognitive*, *smart* or *intelligent* is linked to their performance in providing comfort to occupants and in reducing the overall use of energy (Buckman, Mayfield, & Beck, 2014; Buckman, Mayfield, Meijer, & Beck, 2013; M. Hegger, Fafflok, Hegger, & Passig, 2016; So & Chan, 2012; Wong, Li, & Wang, 2005). Ambiguity remains concerning the meaning of the terms and their differences. Semantically one would assume that there is a certain progression in buildings that are smart, intelligent or cognitive, but some argue that *smart* relates to the building more holistically and includes aspects such as material choice and construction principles, whereas intelligent refers merely to an embedding of intelligent systems in the building (Buckman et al., 2014). There seems to be some agreement that intelligent buildings are controlled by computer systems through a digital infrastructure. In this context, an important role is played by the *building management system* (BMS), which is traditionally the control centre of the building, and that may gain extended capability in case of building intelligence.

In a series of interviews that I conducted in 2015 with professionals in the built environment (architects, engineers, technologists), the ambiguity and agreement described above were echoed. For example, when asking about the difference between smart and intelligent buildings, some responses were:

**“To me, they are one and the same. The smartphone has some intelligence in it. And it is called smart.”**

**“Being intelligent implies somehow a more active role, even making decisions if you want.”**

**“We are so far from this sort of building, it is not interesting going any deeper into the distinctions.”**

**“Smart buildings serve their users in some way, it is not related to technology. It can be highly technological, or not at all. It is more about how it works with the users. ... Intelligence is related to technology, and requires sensors, computers etc.”**

Even with the range of existing interpretations and applications, the picture of a cognitive built environment is one of buildings infused with information technology. These buildings feature sensor networks, artificial intelligence, and sometimes the means to actuate physical change. Consequently, such buildings may feature behaviour that is reactive, interactive, autonomous or adaptive.

This section describes what I call the *cognitive built environment* as the context to which the thesis responds. This context is in constant flux, and developments in the digital technologies that influence the built environment follow each other at breakneck speed. Rather than providing a snapshot of the current state of technology, this section therefore brings a number of ideas into the spotlight

that have remained significant during this time. There are three subsections, of which the first two take the reader through ideas on how intelligence has been interpreted as a force in design, and how artificial intelligence has found its way into the built environment. The third subsection sketches five ways in which ideas of cognition have played into technology and vice versa, with examples of applications in the built environment. These five junctures also serve to illustrate the productive potential of a coalescence to which this thesis also aspires.

## 2.1.1 Intelligence in Design

The notion of intelligence in an architectural context has been understood in a range of different ways. For example, Leon van Schaik has built on Gardner's theory of *multiple intelligences* and argues in favour of a deeper understanding and application of *spatial intelligence* in architectural practice, contrasting it with the more technical approach that it has taken: "What if our forebears had professionalised architecture around spatial intelligence rather than the technologies of shelter?" (Van Schaik, 2008, p. 13). Such spatial intelligence, argues Van Schaik, would bring designers closer to an engagement with lived experiences of space and could instrumentalise their mental space. Notwithstanding the critique on Gardner's work, see for example (Klein, 1997; Waterhouse, 2006), Van Schaik's account is relevant in how it links intelligence to architecture in a non-technological way. In doing so, he also centralises the human. This makes it less suited as a relational theory that includes environment, building and human.

Michael Speaks has written about *design intelligence* as a form of innovation, building on the writing of management consultant Peter Drucker. Beyond philosophy's quest to solve grand problems, or theory (fast-philosophy), Speaks argues that around the new millennium, architectural practices appeared that opportunistically used plausible truths as engines for innovation:

**While vanguard practices are reliant on ideas, theories and concepts given in advance, intelligence-based practices are instead entrepreneurial in seeking opportunities for innovation that cannot be predicted by any idea, theory or concept. Indeed, it is their unique *design intelligence* that enables them to innovate by learning from and adapting to instability. (Speaks, 2006, p. 104)**

Intelligence here is understood not only as a mental capacity, but as the availability of information to designers. When increasingly more information is instantly accessible, Speaks seems to imply, there is a diminished need for laboriously built expertise and grand theories, although it would inevitably require a different set of expert skills. In discussing design intelligence, Speaks argues for the role of prototyping, which will be further addressed in chapter 4.

Nicholas Negroponte writes in the 1970s about architectural design that is intelligently supported by machines. Although his *architecture machines* (Negroponte, 1970) seems to address the machines that would intelligently design architecture along with human architects, much in the thinking tends towards interactions in space. He writes for example: “An architecture machine that could observe existing environments in the real world and design behaviours from the parent would furnish the architect with both unsolicited knowledge and unsolicited problems” (p. 29), and: “Machines that poll information from many designers and inhabitants, directly view the real world, and have a congenial dialogue with one specific designer are architecture machines. They hint at being intelligent machines” (p. 29). The book that followed five years later is more explicit. In it, Sean Wellesley-Miller writes about *Intelligent environments*:

**[T]he fact remains that the concept of a physically responsive environment is being turned from dream to reality by the force, appropriately enough, of environmental circumstances themselves. We are making buildings more context responsive, and in doing so we should not forget that a building’s final context of response is the needs and senses of its inhabitants. (Negroponte, 1975, p. 129)**

In a way, this view of the intelligent environment, or building, has remained unchanged: the building should automatically react to environmental conditions and serve its occupants. What makes these accounts so relevant is the transition from machines that support the design, to machines that support living and the embedded idea that this requires a response from the building.

## 2.1.2 Artificial Intelligence in the Built Environment

A comprehensive overview of current notions of intelligence in the built environment is given by Socrates Yiannoudes in his book on adaptation in architecture (Yiannoudes, 2016b). His insights and examples are used in this section, interpreted and expanded upon where this serves the argument of the thesis.

Yiannoudes sets out by drawing a history of artificial intelligence (AI), starting with the ideas of Leibniz, Alan Turing and the 1956 workshop in Dartmouth that some believe started the field of AI. He sketches the classic approach to AI that prevailed until the 1980s and the rise of connectionism that laid the basis for contemporary neural networks. He concludes with new forms of AI that emerged from the 1980s, revisiting the physicality of the intelligent agent’s body and its interaction with the environment.

According to Yiannoudes, in applying AI to the built environment, the problem with the classic AI is that “an intelligent architectural environment does not act or think like humans but is rather capable of rational autonomous action, providing the appropriate

services in a given situation, and optimizing the functions of the environment” (Yiannoudes, 2016a, p. 59). This is the goal of *Intelligent Environments* (IEs), which is a part of the research programme in Ambient Intelligence (AmI). Intelligent Environments are defined as follows:

**An Intelligent Environment is one in which the actions of numerous networked controllers (controlling different aspects of an environment) is orchestrated by self-programming pre-emptive processes (e.g., intelligent software agents) in such a way as to create an interactive holistic functionality that enhances occupants experiences. (Augusto, Callaghan, Cook, Kameas, & Satoh, 2013)**

Yiannoudes identifies three technologies that support the creation of IEs: *ubiquitous computing*, *ubiquitous communication* and *intelligent user interfaces*. The first two of these technologies support the idea of computing that takes place in a distributed manner. According to Mark Weiser, who coined the term *ubiquitous computing* at the end of the 1980s, this represents the third wave in computing, after mainframes and personal computers, that “forces the computer to live out here in the world with people” (Weiser, 1996). Rather than act on the foreground, computing becomes invisible and takes place in electronics that are embedded in the elements that make up the environment, including those elements that form the built environment. Communication between those elements allows the elements to network and share data. An example of such a network of elements is commonly known as the Internet of Things. Intelligent user interfaces, the third technology, allow occupants to interact with the IE through voice commands and gestures, for example.

Several examples of IEs in buildings are given by Yiannoudes, all of which were developed in a research context.

*iDorm* was a room in the halls of residence at Essex University that was equipped with electronic equipment to monitor occupant behaviour and to activate systems for ventilation, heating, lighting and window blinds. Various handheld devices could be linked to the *embedded agent* that employed *fuzzy logic* to learn, predict and action occupant preferences (Hagras et al., 2004).

*PlaceLab* was a project in the House\_n research consortium at MIT. The project transformed an existing house into an intelligent domestic environment with the aim of generating coherent data sets and distilling occupant behaviour. *PlaceLab* is described as a compromise between laboratory tests and tests in real homes. Laboratory tests place restrictions on the duration of the tests and consequently on the variability of behaviours measured. They also tend to change behaviour. Tests in real homes bring practical limitations to the range of tests that can be conducted simultaneously (Intille et al., 2005).

*PEIS Ecology* (figure 2.1) was developed at Örebro University Sweden with the underlying aim of providing assistance to handicapped occupants. PEIS stands for physically embedded intelligent systems, which included a number of mobile robotic furniture



2.1 PEIS Ecology. A series of screenshots depicting PEIS in action.

objects. The robots, a mobile coffee table with a gripper, and a robot called Astrid, mainly for communication, would be informed by ambient sensor data received from sensors throughout the space. The system was also intended to be scalable, in order for other components to be added (Saffiotti et al., 2008).

Yiannoudes provides some critique of these systems in general. Although ubiquitous computing is already a reality in many parts of the western world, there are issues to consider when it encroaches on the living or working space. He lists concerns about the sense of control, maintenance and privacy.

Outsourcing some tasks to intelligent systems may give occupants a sense of control, but the opposite will be strongly felt when these systems fail, and control is lost. And as is now the case with computational devices such as computers and mobile phones, these systems will need maintenance that may need attending to. Privacy concerns also play a role. First there is the issue of data ownership, and whether collected data in a commercial technology may be sold to third parties. Second, a breach of data may invade the privacy or even the security of occupants. Third, as the autonomy of systems increases, the lack of insight into its workings may induce a feeling of insecurity about the reliability. In turn, this may also lead to privacy concerns.

Where autonomous systems may run in the background unobtrusively and end-user driven systems require more laborious input, the latter may also give occupants a greater sense of control. Yiannoudes concludes that the balance between autonomy and manual control, may ultimately be set by the user to match personal preference.

What becomes clear from Yiannoudes' account and from the general discussion about smart, intelligent, cognitive buildings discussed in this chapter, is that the dominant way of discussing and understanding intelligence in a building context has followed computer science and the various forms of artificial intelligence that have been in vogue. In regard to the building as a machine or as a piece of technology, it seems that intelligence is merely more, or more refined technology; an incremental update to an otherwise normal building.

## 2.1.3 Junctures

The overview provided by Yiannoudes, and other important accounts of the history of artificial intelligence, such as by Russell and Norvig (2010), and by Pfeifer and Scheier (2001), reveal that over the course of history there have been several important parallels and intersections between the fields that study biological and artificial cognition.

We will revisit five of these junctures and look at examples of their implementation in architecture. The first juncture is that of Classic AI and Cognitive Science, which have influenced each other and led to an influential view of human cognition as computational. The second juncture is that of connectionism and the human brain, where the physiological understanding of the workings of the brain led to an influential and successful algorithm in artificial intelligence. The third juncture is found in the cybernetic movement as the idea of intelligent machines, which has left an important legacy to architecture. Embodied AI is the fourth juncture, which sees embodied views of cognition applied to technology such as robotics and architecture. Swarm intelligence, the fifth juncture, has shown how biological processes of emergence have inspired a type of decentralised computational system.

### First Juncture: Classic AI and Cognitive Science

What we now call classic AI can be traced back to the form of computational thinking that was put forward by Alan Turing in the 1930s. In 1950, he wrote a paper that proposed an *imitation game* (Turing, 1950) that would be won by the *thinking machine* if it had become indistinguishable from a human. Later that decade, in 1956, a workshop was held at Dartmouth College in New Hampshire that is regarded by many as the event that formed artificial intelligence as a field. Two participants of the workshop, Allen Newell and Herbert Simon developed a computer programme in 1959 that was called the General Problem Solver (Newell, Shaw, & Simon, 1959), and that would theoretically solve any problem that it was given. This general or broad approach to AI was reflected in the emergence of a multi-disciplinary research programme in psychology, philosophy, neuroscience, computer science, linguistics and anthropology called *cognitive science* (although this term only came into use in the 1970s). The premise was that the human mind is an information processor that manipulates abstract, symbolic structures, similar to how computers operate (Pfeifer & Scheier, 2001; Russell & Norvig, 2010).

Towards the 1970s, some of the initial enthusiasm in AI was tempered by the underwhelming output of the technology, relative to the high expectations that were commonly expressed. It had been the assumption that with an increase in computing power, the successes achieved on simple and abstract cases would scale to complex problems in the real world, but this proved too optimistic. Instead, a trend emerged throughout the 1970s towards more

specific systems that would only operate on particular problems. Such *narrow AI* or *expert systems* would initially be applied in organic chemistry and medical diagnosis, and at the end of the 1980s had become a billion-dollar industry across different sectors (Russell & Norvig, 2010). The development of cognitive science at the same time progressed in various directions, notably in the area of psychology. Various collaborative research groups were founded that joined forces at the 1979 La Jolla Conference on Cognitive Science, which became the first annual meeting of the Cognitive Science Society (Bechtel, Abrahamsen, & Graham, 2001).

Ideas about computation and the mechanics of human cognition were closely aligned and were mutually informing each other. The idea of the brain as a data processor that emerged in this first wave of cognitive science has become criticised in other, more recent, views of cognition as will be further detailed in section 2.2. Some of the problems that classic AI faced, for example, in relation to common sense and emotions, led to the development of other models for cognition that gained traction in the 1980s.

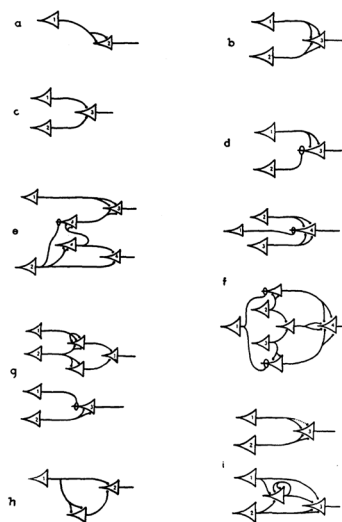

2.2 McCulloch and Pitts' net of nervous activity.

## Second Juncture: Connectionism and the Human Brain

Another model came in the form of a renewed interest in neural networks. Initial work on neural networks, by Warren McCulloch and Walter Pitts was developed in the 1940s and based on then current knowledge of the physiology of the human brain (McCulloch & Pitts, 1943)(figure 2.2). The mid-1980s saw a return to neural networks. After having had little attention for many years, their versatile learning capabilities were collected in an influential publication by David Rumelhart and James McClelland of the Parallel Distributed Processing research group then at UC San Diego (Rumelhart & McClelland, 1986). A view on cognition, described as *connectionism*, lies at the basis of this work, assuming that intelligence, both human and artificial, can be explained by the workings of neurons and their synaptic interconnections (Rumelhart & McClelland, 1986; Russell & Norvig, 2010). Neural networks learn through the reinforcement of the interconnections by repeating patterns.

Neural networks play an important role in recent advances in AI. Since the turn of the millennium, after the success of the narrow expert systems, various AI researchers have called for a return to broad AI, which has been termed *human-level AI* or *Artificial General Intelligence* (Russell & Norvig, 2010). The increasing availability of large amounts of data for learning algorithms has allowed *machine learning* to make significant strides. Especially *deep learning*, which employs multiple layers to derive complex concepts from simpler ones, is one of the fields that attempts to match human intelligence in areas where computers previously had great difficulties (Goodfellow, Bengio, & Courville, 2016). Problems that require intuition and that are not easy to describe in mathematical rules are now solved by programmes such as AlphaGo that combine various computational technologies, including deep neural networks,

and have demonstrated the ability to learn to deal with complex processes without human interference through reinforcement learning alone (Silver et al., 2017).

It should be noted here that a distinction can be made between *strong* and *weak* AI, as proposed by John Searle in a famous paper (1980). Strong AI is the idea of a general human-level intelligence in computers, where computers become minds. Weak AI considers the computer to be a tool, potentially a powerful one, that only simulates aspects of intelligence. These views have coexisted throughout the history of AI, and are still present today. They explain the various facets of research around for example *artificial neural networks* (ANNs). The ANN was inspired by the knowledge of the physiological makeup of the brain, especially the existence of neurones and synapses. Consequent computer simulations using ANNs have served various computational purposes, but have also provided insight into the workings of the human brain. The advancements in ANNs have led to efforts to create human-like brains, for example in projects as Spaun (Eliasmith et al., 2012) or the Blue Brain project (Markram, 2006).

Current ANNs are a class of algorithms used in particular cases of machine learning, applied in many fields. Architectural design and engineering design are no exceptions, and neither are physical implementations in intelligent environments. In particular, for applications where large data sets are available, either supervised or unsupervised, ANNs can detect patterns that inform the design, or adjust parameters in the operation of a building.

### Third Juncture: Cybernetic Movement and the Intelligent Machine

More a movement than a research field proper, cybernetics has brought together disciplines of electrical engineering, mathematics, anthropology, biology, neurophysiology, psychology and arguably others. Since gaining traction as a movement through the ten Macy conferences in New York and Princeton from 1946 until 1953, cybernetics has engaged with the making of intelligent machines through an understanding of dynamic systems. John Johnston remarks that while early AI shifted interest from machines to software, cybernetics remained generally committed to hardware (Johnston, 2008). Although cybernetics is still the subject of a lively research community, much of its contributions have found their way into a broad range of research fields such as robotics, architecture, organisation theory and philosophy.

An important distinction exists between cybernetics of the first and second order. Heinz von Foerster, who first used the term second-order cybernetics, described first-order cybernetics as the cybernetics of observed systems, and second-order cybernetics as the cybernetics of observing systems, or the cybernetics of cybernetics (Foerster, 2003). *Observing systems* in his definition, referred to both systems that observe, as well as the act of observing systems. Søren Brier relates second-order cybernetic systems



to Maturana's idea of *structural coupling*, which is the relation between *autopoietic* systems and their environment (Brier, 1996).

The potential of cybernetics for architecture as a form of system thinking is outlined by Gordon Pask in an article in *Architectural Design* (Pask, 1969). Pask explains that effectively, architects (and engineers) were already system designers without always realising it. He writes that rather than designing buildings as rigid structures for a known purpose, the architect should provide constraints that allow certain modes of evolution in order for architecture to be reactive or adaptive. Pask speculates about such system architecture:

**The high point of functionalism is the concept of a house as a 'machine for living in'. But the bias is towards a machine that acts as a tool serving the inhabitant. This notion will, I believe, be refined into the concept of an environment with which the inhabitant cooperates and in which he can externalise his mental processes, ie, mutualism will be emphasised as compared with mere functionalism. (Pask, 1969, p. 495)**

*Mutualism* is the term Pask uses to refer to the system that contains both the physical structure of a building and the occupants. His vision proposes a type of architecture that is specifically about this mutualism, and where human mental processes are externalised in the building. What this seems to point at is a building that can take on cognitive functions, perhaps relieving the occupant, or even forming a prosthetic extension of the occupant, for enhanced occupation. Such systems should be designed as open ended, Pask suggests, and the *controller*, in this case the building, becomes "an odd mixture of catalyst, crutch, memory and arbiter" (Pask, 1969, p. 496).



2.3 Cedric Price, Generator Project.

An implementation of such a cybernetic mutualism was partly realised in a seminal work by Cedric Price, who had worked with Pask on the *Fun Palace* project in the beginning of the 1960s. The *Generator Project* (figure 2.3), which was never fully built, has nevertheless been named the first intelligent building (Emery, 1980; "Generator, Florida, USA," 1980) (as these project descriptions are anonymous, they may have been written by Price or his project team, there are also others that lay claim to the first intelligent building). Price was commissioned in 1976 by Howard Gilman, the CEO of the Gilman Paper Corporation, to design a facility for dance, theatre and visiting artists at the company's White Oak Plantation on the border of Florida and Georgia. Price developed plans for a building complex that would be always changing. A system was developed as a kit-of-parts that could be easily assembled on a grid of foundation pads, tracks and linear drains. A mobile crane would move the parts: walkways, decks, timber-frame cubical modules and various sub-components, such as cladding panels, furniture and building services.

In December 1978, Price asked John and Julia Frazer to join the project team as systems consultants, explaining to them: "The whole intention of the project is to create an architecture sufficiently responsive to the making of a change of mind constructively pleasurable" (Furtado C L, 2008, p. 58). The design

that was developed subsequently allowed for change as requested by the occupants, but also changes suggested by the building itself. It was foreseen that occupants would not change the building enough. Long states of inactivity would be registered by the building as boredom, upon which it would propose change. Microprocessors in each cube would communicate their position to a central computer, that would record a memory of previous states. Pask's mutualism therefore existed in the building either catering to the occupants' demands, or by independently making proposals for change. Even though the actual project did not develop beyond a crude mock-up on site, a working electronic prototype was built by the Frazers as part of their ongoing research into intelligent buildings.

## Fourth Juncture: Embodied AI

In response to the problems that classic AI ran into in the 1980s, a new AI emerged that was characterised by embodiment and decentralisation. Rodney Brooks at MIT developed a robot control architecture that would further release the notion of *internal representations*, key to the accepted form of AI that was associated with cognitive science. "When we examine very simple-level intelligence, we find that explicit representations and models of the world simply get in the way. It turns out to be better to use the world as its own model" (Brooks, 1991, p. 1). Brooks' *subsumption architecture*, a robot-control architecture, would embed layers of control logic that gave rise to increasingly complex behaviours in the interaction between robot and environment. This work, paralleled by philosophers of mind, emphasised the role of the human body and its actions in the environment in the processes of cognition. Francisco Varela mentions Brooks' work explicitly in his book the *Embodied Mind*, the work that sets out Varela's *enactive* view of cognition (Varela, Thompson, & Rosch, 1992, pp. 208-212). Brooks' work is seen as an encouragement of the philosophical work in enactive cognition:

**The enactive approach, then, is no mere philosophical preference but the result of forces internal to research in cognitive science, even in the case of those hard-nosed engineers who desire to build truly intelligent and useful machines. (p. 212)**

In fact, they portray the robotics work at MIT as enactive: "This example of what we are calling *enactive AI* [emphasis added] is distinctively and clearly formulated as such by its proponents (of course, they do not use our term enactive)" (p. 212). Brooks himself was more reticent to position his work philosophically. He seems aware of the various debates, and acknowledged that there may be similarities between the robotics work he was conducting and certain philosophical thought, but wrote that his work "is based purely on engineering considerations. That does not preclude it from being used in philosophical debate as an example on any side of any fence, however" (Brooks, 1991, p. 10). But the enactive position has since returned in various research efforts in AI and

robotics (Bishop & Nasuto, 2005; Froese & Ziemke, 2009; Suzuki & Floreano, 2008).



2.4 RAAAF and Barbara Visser, *The End of Sitting*.

A particular way in which the enactive view can inform architecture is demonstrated in the installation *The End of Sitting* (2015). The installation (figure 2.4 and 2.7) is a collaboration between RAAAF, an architecture, art and philosophical practice led by brothers Ronald and Erik Rietveld, and artist Barbara Visser. The installation is an indoor artificial sculptural landscape, containing inclined surfaces, voids, troughs and ridges that provide affordances for standing. Erik Rietveld's understanding of affordances is Gibsonian, but he claims it to be broader than generally understood. It takes account of the different affordances that may present themselves to different animals in the same environment, but suggests that "the concept of affordances as applied to humans should be able to straddle differences within the human way of life and accommodate the rich variety of sociocultural practices that are found in the human ecological niche" (Rietveld & Kiverstein, 2014). Rietveld explains affordances in terms of the skilled activities that people employ in their day-to-day dealings with the world and with others, and in that way positions himself in enactive cognitive science. He writes about the installation:

**Within the field of philosophy, *The End of Sitting* is special in that it presents a philosophical worldview, however not in words, as philosophers typically do, but in the form of an enactive art installation. Rather than arguing for the claim that people are embodied minds situated in a landscape of affordances, this sculpture allows people to experience that physically in a landscape of standing affordances that gets them out of their comfort zone and confronts them with new possibilities for action to explore. (Rietveld, 2016, p. 931)**

We see that what is termed an *enactive art installation*, means to convey the enactive position in cognitive science. There is a very practical component to the work that is explained in the video by Barbara Visser (Visser, 2015). A voice explains that in order to design a new type of space, the designers thought in terms of activities rather than furniture. Another voice explains that certain activities, such as pacing up and down, can help structuring thoughts. The landscape, by being anti-ergonomic, forces people to take different positions, which may have health benefits and could, as suggested, impact one's thinking.

On a more abstract level, the enactive position—as set out by Alva Noë, for example (Noë, 2004)—asserts that understanding the world relies on skilful actions, meaning that this way of understanding is learned and practiced. In presenting an environment that is a stark contrast to the day-to-day environment that is navigated almost automatically, this work provides us with a confrontation of the learned skills that allow that navigation, because suddenly the learned patterns have to be readjusted. Even though, over time, adjustment to the new environment will set in, wearing off the confrontational aspect of the installation, its conception and design in terms of opportunities for action would still allow it to be understood as an enactive environment.

## Fifth Juncture: Swarm Intelligence

The last juncture described here relates to a line of research around artificial *swarm intelligence*. In his overview, Yiannoudes describes that in architecture there is “a developing concern for multi-agent and collective-distributed systems, able to demonstrate emergent swarm intelligence, which marks a break with the centrality of Varela’s and Brooks’ embodied subject” (a, p. 61). The often-used analogy for swarm intelligence is that of emerging intelligent behaviour of swarms of bees or flocks of birds, but swarm intelligence asserts that also human cognition is founded in distributed systems, both in the workings of the mind, and in the human as being part of a social community (Kennedy, Eberhart, & Shi, 2001). In his book, James Kennedy and Russell Eberhart also revisit the robotic work by Brooks, and assess his robots in terms of swarms: “[I]nside the robot’s mind there is something of a swarm of modules, you might say, a multitude of subroutines that perform particular functions” (p. 117).

Kas Oosterhuis has been a protagonist of swarm intelligence in buildings. Oosterhuis writes that “[i]ntelligence as I use it here is not seen as human intelligence. It is regarded as emergent behavior coming up from the complex interactions between less complex actuators” (Oosterhuis, 2005, p. 95). His references are not so much flocks of birds, or the brain as a swarm, but he lists experimental technologies at that time, such as *Smart Dust*, *Utility Fog* and *Boids* as complex systems that serve as a model for what he calls *a new kind of building*, a reference to the title of Stefan Wolfram’s book *A New Kind of Science*. Wolfram discusses, amongst other things, the complexity of cellular automata, the workings of which Oosterhuis adopts as an analogy for the design process. Influenced further by Kevin Kelly’s popular *Out of Control* (Kelly, 1994), Hyperbody sought to create buildings that would respond in real-time with an intelligence that emerged from the communication between multiple distributed agents. A notable implementation was in *Muscle NSA* (2003), exhibited at the *Architectures Non Standard* exhibition in Paris (figure 2.5).

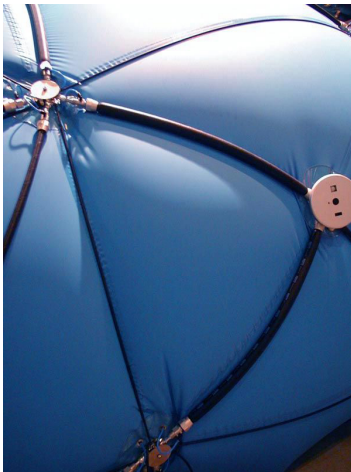

2.5 Hyperbody, Muscle NSA.

Oosterhuis envisaged the swarm of various building components interacting with other buildings and occupants alike, suggesting heterogeneous swarms. Contemporary research into swarm robotics also investigates heterogeneous systems, such as the work of Mark Dorigo’s research group in Brussels, or that of Carlo Pinciroli on the simulation of robot swarms. Building on the robustness of swarm systems—even if multiple agents fail, the system as a whole is still operational—heterogeneous systems allow for specialisation and diversity, not unlike the components that make up a building.

A contrasting approach to the application of swarm intelligence in buildings is proposed by Rupert Soar, a researcher who has spent considerable time in Namibia observing swarm behaviour of termites. Their behaviour, their use of materials and the symbiosis in which they engage, lead to the construction of permeable membranes that subtly modulate the internal climate of termite mounds. Soar’s definition of intelligence, as “the regulation of matter, energy or information (MEI) states, by agents with

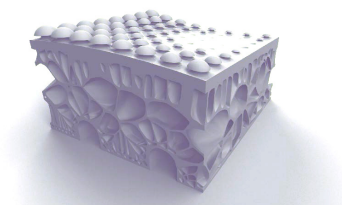

**2.6** Freeform Construction, Mineral Skin digital prototype.

objectives” (Soar, 2016a, p. 2) fits the mechanistic perspective of the termites at work. His objective is to transpose the resulting organisation, the complex mound structure with its intricate network of pores, to buildings for humans (Soar, 2016b). Although such a structure (figure 2.6) would be less flexible and adaptive, it would still maintain the intelligent qualities of the termite structures. As design and construction phases grow closer, due to developments in digital fabrication, the building would become increasingly adaptive, with ultimately the application of “robotic construction agents to undertake the same process of negotiation, but, onsite, for the immediate negotiation of environmental constraints” (b, p. 15).

Although both Oosterhuis and Soar are invested in the mechanics of artificial swarms, they start and end at different places. Oosterhuis seems less concerned with the biology of swarms and chooses his starting point in the technological analogies. The swarm then serves to support the abstract idea of emergent behaviour as a foundation of his intelligent architecture. Soar on the other hand, has furthered the understanding of the behaviour of certain termite swarms and looks to capitalise on the output of the swarm at work in the form of the complex physical structures they produce.

**2.7** RAAAF and Barbara Visser, The End of Sitting.



## 2.2 From Cognitivism to Enactivism

As cognition is the subject of a number of different research fields, a single precise definition is difficult to obtain. However, the definition provided by the Oxford Dictionary is helpful in relating cognition to other concepts. It reads: “The mental action or process of acquiring knowledge and understanding through thought, experience, and the senses” (Cognition, n.d.). This definition attributes cognition to a mind and describes it as an action or a process of that mind. It further states that cognition is for the acquisition of knowledge and understanding. Lastly, it provides the means necessary for a cognitive process: thought, experience and the senses. This definition thus connects cognition comprehensively to the related concepts of mind, intelligence, memory and perception.

Together, these terms form the area of interest of research in various disciplinary fields such as philosophy, psychology, neuroscience, linguistics, anthropology and artificial intelligence. From the 1950s to the 1970s, interdisciplinary efforts led to the creation of a new field that was called *cognitive science* where scientists from the earlier-mentioned disciplines would approach the workings of the mind. *The Blackwell Dictionary of Cognitive Psychology* lists the areas of focus of cognitive science as: knowledge representation, language, learning, thinking, and perception (Ellis, Hunt, & Johnson-Laird, 1985). Working within the field, Herbert Simon and Craig Kaplan define cognitive science as “the study of intelligence and intelligent systems, with particular reference to intelligent behaviour as computation” (1989). Their introductory chapter in *Foundations of Cognitive Science* (Posner, 1989) sets out the field, with particular attention to various proposed *architectures* of information-processing systems, or in other words, models for the workings of the human brain. They explain: “Computers and (in our view) human beings are symbol systems. They achieve their intelligence by symbolizing external and internal situations and events and by manipulating those symbols. They all use about the same symbol-manipulating processes” (Simon & Kaplan, 1989, p. 40).

This section has three subsections. The first two subsections address two broad areas that have developed partly in response to cognitive science: artificial intelligence and embodied cognition. For each area, three problems are highlighted that cognitive science could not seem to resolve in the direction it was heading. Different approaches provided ways around those problems but required a radical break with traditional cognitive science. In the third subsection *enactivism* is singled out as one of the approaches that was found to be productive for this research. Enactivism was influenced by both areas of artificial intelligence and embodied cognition. Four key aspects of enactivism are described that position this research in terms of cognition.

## 2.2.1 Three Problems in AI

Developments in some of the related fields of cognitive science, notably philosophy of mind and AI, sought to address various structural problems that traditional cognitive science seemed unable to resolve. Rolf Pfeifer and Christian Scheier, writing about AI for robotics, identify three fundamental problems with the traditional approach, which they call the *frame problem*, the *symbol-grounding* problem and problems of *embodiment and situatedness* (2001).

The frame problem is related to how a cognitive agent deals with changes in the environment and it suggests that the traditional approach is not suitable for doing this efficiently. The underlying idea is that cognitive science assumes a mental model, or representation of the world, to exist in the mind of the cognitive agent. The frame problem therefore relates to how this representation is kept up to date when change occurs in the world that it represents.

The symbol-grounding problem states that there is a disconnect between the symbolic system that exists in traditional cognitive models and their meaning in the real world. Symbols in such systems relate only to other symbols, and through human interpreters such symbols get significance outside the closed symbolic systems. This makes the symbol-grounding problem important for the development of autonomous robots. Pfeifer and Scheier write that this problem is inherent to symbolic systems, and can only be overcome by using a different approach altogether.

The problem of embodiment asserts that traditional cognitive science does not sufficiently recognise that cognitive agents require a body to interact with the world. Only if a cognitive agent has a body, can it be known for sure that it is able to interact with the world. If a system is not embodied, the symbol-grounding problem applies. The work of roboticist Rodney Brooks was influential in the emergence of an embodied approach to cognition that addresses these three problems.

### Brooks' Creatures

In experiments at the Artificial Intelligence Laboratory at MIT in the 1980s, Rodney Brooks developed a new breed of robots. Brooks' robots were perhaps less advanced in the hardware they employed than other robots at the time, but some aspects of their performance outmatched those of the traditional robots.

A groundbreaking and successful robot at the time was *Shakey* (figure 2.8), developed at Stanford Research Institute from 1966 until 1972 (Nilsson, 1984). *Shakey* could deal with relatively complex instructions and would move by itself, navigating around obstacles and through doors. Like other robots at that time, *Shakey* adhered to an architecture of sense-plan-act. Such robots would



2.8 Shakey.

sense their environment with a variety of sensors and build a representation of this environment in their digital memory. Based on this representation, the robot would plan the actions of the robot, which it would then execute.

The three problems identified by Pfeifer and Scheier (frame, symbol-grounding, embodiment) can be illustrated with sense-plan-act systems. First, such robots were too slow to deal with changes in the environment. Once the robot had built a representation of its environment (and established the frame), the environment could have changed, and the planned actions would be misguided. Second, the symbol-grounding problem played a role in that robots could only interpret whatever they were programmed to do. And third, although the robots had a body located in space, they were not embodied and situated in the sense that they were not really in tune with their environment. Instead, they were controlled by an overhead of logic and information that would by definition lag behind.

One of the *creatures* developed by Brooks, was *Genghis* (figure 2.9), a six-legged robot that adhered to a new robot architecture. This *subsumption* architecture was developed by Brooks and can be described as a layered system of behavioural controls, from low-level basic rules that could be overridden by more complex rules when necessary (Brooks, 1986). As a general rule, *Genghis*' legs would just peddle in one direction and as a result made the robot walk. The affordance of the floor, providing resistance, would make the interaction between the robot and the floor result in walking behaviour. A leg would be restricted as it hit an obstacle and follow a higher-level rule, leading it to reach up. This would result in the robot scaling the obstacle and displaying climbing behaviour. Instead of a central computer that would be programmed to deal with specific scenarios, *Genghis* would make up its actions on the go. It was a robot that was situated in its environment, and rather than relying on a representation of that environment, it would deal with it when it mattered. Brooks would later argue that there was no need for a detailed representation, even that “models of the world simply get in the way. It turns out to be better to use the world as its own model” (Brooks, 1991, p. 1). The robots developed in this vein were embodied and situated cognitive systems, lacking the need for a complex overhead to synchronise representations, and all their logic would be directly relevant for their interactions with the environment.



2.9 Genghis.

## 2.2.2 Three problems in Philosophy of Mind

Robert Wilson and Lucia Foglia identify three problems in traditional cognitive science that would lead to embodied notions of cognition: *modularity of mind*, *mental representations* and *nativism* (R. A. Wilson & Foglia, 2016).



Modularity is the idea that domain-specific, independent neural structures exist that perform certain cognitive tasks. Jerry Fodor suggests for example the existence of such modules for colour perception, shape analysis and voice recognition (Fodor, 1983, p. 47). Wilson and Foglia explain that this idea is also supported by evolutionary theories of mind that argue there is an evolutionary advantage to having a robust and redundant system of independent modules where the failure of one would not critically affect the others. A problem for modularity is that experiments have shown that certain capacities, thought to be contained to isolated modules, affect each other. There is research that suggests, for example, that sensorimotor processes contribute to understanding language (Kaschak & Glenberg, 2000), or that perceptual experience relies on imagined or anticipated embodied interaction (Hurley, 2001). It seems necessary therefore that at least some parts of the mind should be dedicated to integrating different modules. A further problem for modularity is that of neural plasticity, which asserts that certain parts of the brain can stand in for others (Robbins, 2017).

Mental representations in cognitive science have been understood as symbolic structures that carry content and are independent and decoupled from the senses and from bodily action (e.g., Fodor & Pylyshyn, 1988; Newell & Simon, 1972). Mental representations are a fundamental concept of computationalism, which asserts that cognitive processes exist as the various manipulations of representations (transforming, storing) (Pitt, 2017). Representations are often considered to be internal to the mind and may reflect conditions that are external to it. One problem with mental representations is that they are understood to exist independent of the senses. Another problem is that internal mental representations do not explain how consciousness is produced and how consciousness varies for different sensory modalities (Noë & O'Regan, 2002). Research on phenomena such as visual stability, change blindness and sensory substitution has led to a questioning of traditional representations, and various proposals have emerged that downplay the significance of representations, or do away with them altogether (Chemero, 2011; O'Regan & Noë, 2001; R. A. Wilson & Foglia, 2016). Some researchers have argued that representations are simply not needed, as “many problems in perception evaporate if we adopt the view that the brain need make no internal representation or replica or ‘icon’ of the outside world” (O'Regan, 1992, p. 464) and “we are built in such a way that we can get the information about the world that we need, when we need it (Noë, 2004).

Nativism is the idea that the environment does not have a role in shaping cognition, but only in activating its pre-existing structures. Such rich internal structures are therefore a key concept in nativism. Consequently, learning becomes the process of filling in such structures. Robert Wilson contends that this position is seldom kept in its extreme form, but that cognitive science holds a range of positions from nativist to empiricist views, of which the latter lends more emphasis to environmental exposure (2004). The problem, at least with strong nativist views, is that they contravene ideas of learning and flexibility, and as Steven Quartz and Terrence Sejnowski point out, place a significant burden on genetic

mechanisms (Quartz & Sejnowski, 1997). According to them, research suggests that the brain evolves towards more flexible, rather than innate, specialised structures.

## Embodied cognition

In the emergence of embodied views of cognition, a number of developments can be identified that helped them take shape. One of these developments was the insight that figurative language based on bodily experiences plays an important role in how we understand the world. Lakoff and Johnson argue that metaphors structure cognitive processes such as those related to space and time (1980). For example, they write that spatial concepts captured in *orientational metaphors* like *up* and *ahead*, are related to our physiology and how our body moves through space. As we typically walk in a forward direction, we can speak about things that are ahead of us as things that are yet to come.

Another development was the work of Francesco Varela and the publication *The Embodied Mind*, with Evan Thomson and Eleanor Rosch (Varela et al., 1992). This work aimed to bring the phenomenological perspective developed by the philosopher Maurice Merleau-Ponty into cognitive science, and led to the *enactive view* of cognition. In the enactive view, cognition is brought forth through an active engagement with the environment. The work builds on previous work Varela undertook with Humberto Maturana, particularly in its reliance on the concept of *structural coupling*. Varela et al. also reference the work of Rodney Brooks, discussed earlier in this section, and suggest the existence of enactive AI. This shows that developments in AI and philosophy of mind have influenced each other in important ways.

Wilson and Foglia have proposed three ways of looking at the body, which help explain how embodied cognition relates to the three outlined problems of cognitive science (R. A. Wilson & Foglia, 2016). They refer to the *body as constraint*, the *body as distributor*, or the *body as regulator* of processes of cognition.

The body as constraint determines what and what type of content is part of an agent's cognitive processes. For example, the particular way that the auditory sense has developed in humans determines how sound is perceived and experienced. Understanding the body as constraint runs counter to ideas of nativism. The body as constraint assumes a critical relation between the body and the environment, a relation that has evolved and developed to interact with the environment in a very particular way. In nativism the environment is merely a trigger that activates existing structures. The enmeshed condition that underlies the body as constraint is, as such, not recognised in nativism. The way in which evolved processes of interaction with the environment operate, often drawing on multiple capacities at once, also contradicts ideas of modularity, where such processes would be regarded in isolation.

The body as distributor shares the cognitive load between neural and non-neural structures throughout the body, and as some argue, also outside the body. The body as distributor is difficult to connect to ideas of modularity. The distributor assumes a role for the whole body, sometimes also outside the body, to contribute to cognitive processes. These are not isolated processes, as the modularity thesis asserts, but complex networks that involve neural and non-neural material substrates. Where the distributor attributes a cognitive role to the environment, this also contradicts nativism.

The body as regulator coordinates cognitive processes in time and space. Like a speed governor, it regulates such processes in real time, using intrinsic mechanisms of the body. The body as regulator has no place for representations. It assumes that mechanisms have evolved in the body that directly react to certain inputs, forming a complex, dynamic system. Representationalists suggest that we should rely on expensive computational models that require representations to be constructed and analysed. Anti-representationalists who support dynamic systems theory or radical enactivism claim that systems without representations are sufficient to explain processes of cognition.

## Six Claims of Embodied Cognition

Margaret Wilson aligns embodied cognition along six distinct claims that she distilled from the literature (M. D. Wilson, 2002). These claims point in various directions and paint a picture of embodied cognition as a cluster of views, rather than a unified perspective on cognition.

Claim 1 is that cognition is situated. It states that cognition takes place in a real-world context and involves perception of, and action in that context. This claim is supported by ideas of the body as constraint that regard the body as an evolutionary response to the environment with a set of particular ways of interacting with it. The body as distributor also lends support, in that acting of the body is understood as tightly related to cognition.

Claim 2 states that cognition is fundamentally a real-time process. This can be understood as a further specification of situatedness that takes not only the situation into account, but also time. This claim is tied to the ideas of the body as regulator and seeks to understand the body as a system of efficiency with little time for costly processes.

Claim 3 is that the environment is deemed supportive of cognitive functions. Specific cognitive tasks are offloaded to the environment. This claim relates strongly to the body as distributor, where the environment can become part of a distributed cognitive system. As the cognitive system should also be attuned to the environment in order to establish this, the constraint thesis also lends support to this claim.

Claim 4 states that the environment is a constitutive part of the cognitive system. In a sense this is a strong version of claim 3 that merely leans on the environment for cognitive processing. Also, in this strong version, the body as distributor is the model that supports the claim.

Claim 5 declares that cognition is inherently for action and to guide behaviour. Although interpretations here differ (is cognition for action, or is action for cognition?), the claim clearly identifies an important relation between action and cognition supported predominantly by research into visual perception. Both body as distributor and constraint support this claim. The body as distributor explains how other than neural systems contribute to cognition and the body as constraint sets out how the particular physicality of the body is adept at dealing with its environment.

Claim 6 states that even if cognitive processes concern abstract thought and not the direct interaction with the environment (off-line), the mind still employs the same mechanisms that support this interaction. The body as distributor lends support to this in that the whole body and not just the neural substrate is employed in processes of cognition. To assume that neural structures alone could be capable of standing in for those located elsewhere would contradict the very idea of the body as distributor.

## 4E Cognition

Embodied cognition as outlined in the previous subsections has been presented as a collection of views that may all be embodied, but that show differences in how the body relates to the environment, in how much of it and how it is embodied or external to the body, and in the significance that is attributed to the existence of representations. Many of the ideas that constitute these views are rooted in philosophical work developed from the end of the nineteenth century, notably by John Dewey, Martin Heidegger, Maurice Merleau-Ponty, and Ludwig Wittgenstein (Gallagher, 2009). The term *situated cognition* has been used to address these views (Robbins & Aydede, 2009; Smith, 1999), which were recently revived through developments in cognitive science, AI, and robotics. Also gaining traction is *4E*, a term coined by Shaun Gallagher as an umbrella term for *embodied*, *embedded*, *enacted*, and *extended* views on cognition (Rowlands, 2010, p. 219). Richard Menary argues that combining these four views under a single expression risks losing sight of their nuances and incompatibilities. But their unanimous rejection of traditional cognitivism and methodological individualism is strong enough a case to regard them together (Menary, 2010).

Another reason to group the four E's might be that the histories of the four views have developed alongside and informed each other. And given that there are also, sometimes conflicting, differing interpretations within each of the named views, it may help to cluster the 4E together in order to better understand the larger field. 4E further suggests a flat organisation of the E's, placing

them side by side, rather than a hierarchical structure where some E's are subordinated to others. As a guide to the reader, the four views could be characterised as follows: (1) Embodied cognition states that cognition is a function of the whole body, not just the brain. (2) Embedded cognition states that cognition is a function of the body in the world. (3) Enactive cognition states that cognition emerges from the active engagement of the body with the world. (4) Extended cognition states that cognition lies in part in the world, and not just in the body.

# Enactive

**Coupling  
Acting Out  
Exteriorisation**

## 2.2.3 Enactivism

The main cognitive view that this research subscribes to is that of *enactivism*. As one of four E's (embodied, embedded, enacted, extended), the enactive view is understood to be part of a broader field, and the approach taken in this thesis is that of adopting an inclusive reading of enactive cognition that is embodied, and that also accepts, like extended cognition, that cognitive processes in part comprise aspects outside the body. Three key notions that underpin this enactive view are highlighted in this section, pinpointing the specific use of enaction in this research. These notions are *coupling*, *acting out* and *exteriorisation*. Arguably, these notions are interlinked and interdependent, but in order to make them productive in the thesis, they will be addressed separately. Due to the interrelatedness of these notions with the contentious topic of representations in the mind, representations will be addressed first in a separate section.

In 1964, the psychologist Jerome Bruner published a paper discussing the development of human cognition (Bruner, 1964). The paper identifies three progressing stages of cognitive development that align with modes of representation, based on action, imagery and language, respectively. The first mode, which he calls *enactive representation*, explains a sort of muscle memory that constructs a presence based on bodily activity. Recognising the work of Bruner in a diagram that maps the state of cognitive science (but not his terminology) almost 30 years later, Varela, Thomson and Rosch describe a new way of understanding cognition in *The Embodied Mind* (Varela et al., 1992). In it, they propose the use of the term *enactive* in order to

**emphasize the growing conviction that cognition is not the representation of a pregiven world by a pregiven mind but is rather the enactment of a world and a mind on the basis of a history of the variety of actions that a being in the world performs. (Varela et al., 1992, p. 9)**

Varela et al. propose to use the term *enaction* in relation to the mechanics of embodied cognition, as a form of interpretation, that is the “*enactment or bringing forth of meaning from a background of understanding*” (p. 149). Enactment thus is a process of making sense of the world, enabled by the accrued skills and experiences one has from living life.

Since the publication of *The Embodied Mind*, the enactive view of cognition has developed in what Dave Ward et al. have identified as three directions: autopoietic enactivism, sensorimotor enactivism and radical enactivism (Ward, Silverman, & Villalobos, 2017). The key differences between these directions are matters of emphasis. Autopoietic enactivism extends directly from the work of Varela et al. with a focus on biodynamic interaction that gives rise to cognition. Sensorimotor enactivism focusses on the emergence of perceptual experience through the relation between perception and action. And radical enactivism is made distinctive by its deep scepticism and outright rejection of representations in the mind. Ward et al. also discuss other members of what they call

the *enactivist family*, including extended views of the mind that exteriorise constitutive elements of cognition. The compatibility between extended cognition and enactivism is disputed. However, as will be shown, some have argued for enactive views that are inclusive of aspects of the extended view, such as exteriorisation. The thesis developed by the French philosopher Bernard Stiegler, provides a frame for discussing technology as a form of external cognition.

## Representations

The position of embodied cognition generally takes issue with the idea of representation, which forms an important part of traditional cognitive science. Such representations are symbolic structures, or models, typically understood to reside in the brain, and are believed by some to correspond to neural states. Varela et al. place Realism and Idealism at opposite ends of a spectrum where physical and mental worlds respectively are taken as points of reference. Both views, they remark, rely on the idea of representation. Either by fostering an imperfect model in the mind of an outer world (Realism), or to construct such a model entirely within the mind (Idealism). In declaring their own position, Varela et al. place themselves between the two extremes, and argue for a *middle way* in which neither outer nor inner are starting points, but where “world and perceiver specify each other” (Varela et al., 1992, p. 172). In this middle way, cognition is neither the recovery of an external world or the projection of an internal world, but cognition is embodied action. Cognition is the result of a body in active engagement with the world, with its environment. The term *embodied*, they explain, not only means that there is a physical body, but that the body’s capacity to perceive is part of (and has developed as the result of) a larger context that is biological and cultural.

Varela et al. declare at the outset that their work on embodied cognition is a *modern continuation* of the work that was started by the French philosopher Maurice Merleau-Ponty. The position of a middle way had already been proposed by Merleau-Ponty in 1945. He wrote: “The world is inseparable from the subject, but a subject who is nothing but a project of the world” (Merleau-Ponty, 2012, p. 454). Merleau-Ponty’s idea of a *reversibility* between perceiver and perceived stemmed from an approach to avoid the binary division between mental and physical realms that is commonly linked to the work of René Descartes. The mind-body problem was an artificial, human-made problem, which Merleau-Ponty sought to counter with a new ontological category that assumes a primordial continuity between subject and object. He called this the *flesh of the world*.

**Visible and mobile, my body is a thing among things; it is caught in the fabric of the world, and its cohesion is that of a thing. But because it moves itself and sees, it holds things in a circle around itself. Things are an annex or prolongation of itself; they are incrustated into its flesh, they are part of its full definition; the world is made of the same stuff as the body. (Merleau-Ponty, 1964, p. 163)**



In *Merleau-Ponty for Architects*, Jonathan Hale explains the flesh of the world:

**This idea suggests that the everyday understanding of ourselves as experiencing subjects – distinct from the world of objects – is not where perception begins but actually where it ends. [Merleau-Ponty] is therefore proposing a new way of thinking about experience, where consciousness is seen as an emergent property of embodied action in the world. (Hale, 2016, p. 65)**

Varela et al. use examples from the perception of colour to illustrate the reciprocity of world and perceiver. Where colour certainly depends on particular quantifiable properties of materials, its perception cannot be understood independently from physical context, from the biological makeup of the visual nerve system and from a history of seeing colour. Both outer and inner conditions determine how colour is perceived and understood. Varela et al. provide accounts for how this unfolds.

First, phenomena such as *colour constancy*, *chromatic induction* and *perceptual interaction* can be said to play a role. How colour is perceived in these cases does not directly relate to measurable parameters such as lux levels and wavelengths. Past experience plays a role through expectations and memory, as do aspects such as visual context and context from other sense modalities including associations with sound and the sense of equilibrium. Second, the neurological processes that support these cognitive processes are part of a biological make-up that has evolved over time. The perceiver is physiologically developed to perceive colours in a certain way. There is a particular way of perceiving colour in humans that has been advantageous for its being in the world, just as there are notable other ways in for example goldfish and pigeons. Cultural factors such as the learned language can also influence how certain colours are perceived.

Following the middle way, as an alternative to representationalist views, enactive cognition brings forth a world through direct perception. The specific physiological make-up allows the organism to make use of the sense modalities to which it has developed a sensitivity, and that present the world in a particular way. The enactive view argues that there is simply no need for representations. The world serves as an outside memory, with an apparent infinite richness because of its availability for further exploration at any time (O'Regan, 1992).

## Coupling

*Structural coupling* is a concept that was developed by Humberto Maturana with Francesco Varela in *Autopoiesis and Cognition* and later in *The Tree of Knowledge* as part of their theory of *autopoiesis* (Maturana & Varela, 1980; 1992). Maturana and Varela developed the theory in order to define living beings. Two important notions in autopoiesis are that of *organisation* and *structure*:

**Organization** denotes those relations that must exist among the components of a system for it to be a member of a specific class.

**Structure** denotes the components and relations that actually constitute a particular unity and make its organization real. (Maturana & Varela, 1992, p. 47)

When alive, an organism's organisation therefore remains the same, while its structure is constantly changed. Autopoietic organisations are autonomous, confined to a boundary and the only product of an organisation is itself. An organisation is producer and product at the same time: "The being and doing of an autopoietic unity are inseparable, and this is their specific mode of organization" (p. 49).

This producing of itself, or *ontogeny*, is a constant change of its structure. As long as the entity is alive, any structural change will not result in organisational change. Structural change may be triggered by the environment or by other autopoietic entities: "We speak of structural coupling whenever there is a history of recurrent interactions leading to the structural congruence between two (or more) systems" (p. 75).

The concept of structural coupling thus explains how organisms and environment are reciprocally affected. Strictly, the definition "is not peculiar to living systems. It is a phenomenon that takes place whenever a plastic composite unity undergoes recurrent interactions with structural change but without loss of organization" (Maturana & Varela, 1980 p.xxi). The concept has been used extensively in *The Embodied Mind*, as a critical concept underlying enaction. It explains how a perceiving organism operates in an environment of its own perceptual making, while that environment is at the same time affecting how the perceiver operates. Here, Varela et al. do not reject an external, physical world with given properties, or an autonomous perceiver with internal cognitive abilities, but they write that both entities are coupled: the cognitive capabilities of the perceiver are fundamentally tied to the ability to act in the world it inhabits, and these abilities have evolved over generations of lived history. The idea of such a mutual relation has its roots in the earlier work of other scholars, notably that of French philosopher Maurice Merleau-Ponty.

Through evolution, organisms have become attuned to the specifics of the environment they inhabit; they have developed a sensory system that picks up on the stimuli that have somehow proven to be relevant. The organism is formed by what James Gibson describes as the particular environment that affords this organism to live, their *niche* (Gibson, 2014). In choosing their niche, organisms become sensitive to particular conditions. In *The Structure of Behaviour* (1967), Merleau-Ponty quotes Kurt Goldstein (1934), who describes how organisms carve out their own environment while going about their business. Goldstein's translated passage is as follows:

**The environment of an organism is by no means something definite and static but is continuously forming commensurably with the development of the organism and its activity. One**

could say that the environment emerges from the world through the being or actualization of the organism. Stated in a less prejudiced manner, an organism can exist only if it succeeds in finding in the world an adequate environment - in shaping an environment (for which, of course, the world must offer the opportunity). (Goldstein, 1995, p. 85)

In Merleau-Ponty's words, the organism selects its responsiveness to certain stimuli in the physical world:

**Thus the form of the excitant is created by the organism itself, by its proper manner of offering itself to actions from the outside. Doubtless, in order to be able to subsist, it must encounter a certain number of physical and chemical agents in its surroundings. But it is the organism itself - according to the proper nature of its receptors, the thresholds of its nerve centers and the movements of the organs - which chooses the stimuli in the physical world to which it will be sensitive. (Merleau-Ponty, 1967, p. 13)**

In the words of Varela et al., this relation between organism and environment is a mutual specification. The environment specifies the organism by providing specific conditions for it to evolve. The organism specifies the environment by choosing which part of the environment to be receptive to. While disruptions of the environment cause change in the structure of the organism, the organism causes change by acting in and on the environment. Structural coupling is therefore a process of becoming that works over generations (phylogenetically) and directly on the organism (ontogenetically).

## Acting Out

To understand cognition as enactive implies the downplaying or rejection of the position that cognition fundamentally relies on the retrieval of representations, whether these are from a pregiven external world, or from internal projections. Varela et al. propose a middle way that regards cognition as *embodied action*, circumventing any representational mechanism. They explain that *embodied* should be understood both as having a body with sensing and motor capacities and also as those capacities to be embodied in a biological, cultural and psychological context. *Action* seeks to emphasise the relation between sensory and motor processes, between perception and action in the world. Their position is that processes of sensing and motion cannot be separated. "Indeed," they write, "the two are not merely contingently linked in individuals; they have also evolved together" (Varela et al., 1992, p. 173).

Merleau-Ponty addresses bodily awareness through the notion of the *body schema*. Such body schemas emerge through a combination of our capacity of proprioception and ongoing engagement with the world that leads to behavioural patterns and the development of skills. Body schemas should not be regarded as

representations, but as capacities to deal with specific situations. And while addressing a specific task, certain parts of the body are called upon, while others that are not directly engaged disappear from our awareness. The body schema therefore helps making sense of the world and feeds into what Merleau-Ponty called *motor cognition*, described by Jonathan Hale as “a pre-reflective bodily grip on the world as a set of structured arenas for action” (Hale, 2016, p. 17). This idea of opportunities for action provided by the environment resembles what has been later described by the psychologist James Gibson as *affordances* (Gibson, 2014).

Merleau-Ponty’s discussion about the use of tools relies on the body schema, as it suggests that, with practice, tools can become part of the body schema. The cane for example that is used by a blind person to navigate can be described as an extension of that person’s body schema. As the tip of the cane moves across a smooth, rough or bumpy surface, the sensations can be initially said to be tactile to the hand that holds the cane. But with time, the cane itself disappears and the feedback, tactile and acoustic, directly translates into a perception of the environment.

**But habit does not consist in interpreting the pressure of the cane on the hand like signs of certain positions of the cane, and then these positions as signs of an external object – for the habit relieves us of this very task. The pressures on the hand and the cane are no longer given, the cane is no longer an object that the blind man would perceive, it has become an instrument with which he perceives. It is an appendage of the body, or an extension of the bodily synthesis. (Merleau-Ponty, 2012, p. 153)**

In recalling Merleau-Ponty’s image of the blind man probing with a cane, philosopher Alva Noë explains that in the enactive view, perception is like touch (Noë, 2004). We use our body, he argues, to actively probe the world, and it is this process of probing that constitutes perception. The physiology of the body coupled to the environment therefore determines to a great extent how this perception unfolds; a change in physiology would mean an altogether different experience of the world.

Although the relation between action and cognition is given much significance in embodied cognition, many of its proponents suggest that cognition is in essence aimed at acting, is *for* action. In a paper from 2001, Alva Noë and Kevin O’Regan present a sensorimotor account of visual perception, proposing instead that perception works *through* action (O’Regan & Noë, 2001). Based on two types of experiments, the paper initially takes aim at the idea of internal representations, an idea that is widespread in fields that study the nature of vision and visual consciousness. An analysis of phenomena such as *visual stability*, *filling-in* of the blind spot, and *change blindness*, which are investigated in the first type of experiment, demonstrates that how we visually experience the world is incompatible with the concept of picture-like representations in the mind.

The second type of experiments concern *sensorimotor adaptation*, *sensory substitution* and *synesthesia* effects. These experiments

support the idea that sensory experience emerges from repeated patterns that link specific bodily movements to sensory variation. Noë and O'Regan term such patterns *sensorimotor contingencies*. An example they use is the perception of colour, and its perceived constancy in changing conditions. “[T]he visual experience of a red color patch depends on the structure of the changes in sensory input that occur when you move your eyes around relative to the patch, or when you move the patch around relative to yourself” (O'Regan & Noë, 2001, p. 951). The variations include the light level on the patch, its surface reflection, or where on the retina the patch activates the optic nerve. Through all those variations, the same colour red is perceived. In fact, it is through these variations that we perceive the same red, because we have learned how red varies under which conditions.

The deliberate variation of sensations is therefore said to be the strategy to perceive. After having learned, or having become skilful in applying the patterns of sensorimotor contingency, the world is perceived in a manner akin to touch. This can be further explained by referring to the phenomenon of sensory fatigue (Noë, 2004). This phenomenon entails the fading of static sensory stimuli: we do not continually feel that we are wearing clothing, and we do not smell the environment we are in for some time. The micro-saccadic movements of our eyes, for example, contribute to the persistence of our visual sensation. Sensing something by touch requires movement. Noë and O'Regan therefore argue that perception is *something we do*.

## Exteriorisation

By leaning on the notion of structural coupling, in regarding the world as its own representation and through the significance of active engagement with the environment, the enactive view places much importance on the external environment. Philosophers Andy Clark and David Chalmers proposed their now famous thesis of an extended mind, which states that aspects of the environment are constitutive of the mind (A. Clark & Chalmers, 1998). While this stance is not uncontested in enactive views of cognition, three positions are highlighted here that do accept a form of extension as part of enactive cognition, opening a path to incorporate the theory of French philosopher Bernard Stiegler in the same context.

Ezequiel Di Paolo (Di Paolo, 2008), and more recently Gabriella Colombetti (Colombetti, 2015), have argued from an autopoietic enactive point of view that the boundary of a living, and therefore cognitive, being may extend beyond the biological boundary of the organism. An example they use is that of aquatic insects that cultivate air bubbles for breathing during their sustained submersion. Such air bubbles, although not part of the physical body of the insect, become vital for their underwater presence. In autopoietic terms, the air bubbles mediate the structural coupling between the organism and its environment.

Argued from a radical enactivist standpoint, Daniel Hutto, Michael Kirchhoff and Erik Myin (Hutto, Kirchhoff, & Myin, 2014) show that removing the requirement for contentful representations to explain cognitive processes allows a view of cognition that is constitutively world-involving and that they term *extensive*. In removing the need for representations, they differ from internalists (who claim cognition is brain based) and from most supporters of the extended mind thesis, who also adhere to a form of representationalist cognition.

John Stewart's description of the foundational issues for a paradigm of enaction (Stewart, Stewart, Gapenne, & Di Paolo, 2010) includes an account of tool using and of writing. The explanation of the use of tools as technical artefacts resembles Di Paolo's air bubbles: tools mediate the interactions between the organism and its environment. Stewart argues that writing, as a material technology, serves, or is, the clarification of thought. Writing is therefore a form of exteriorised cognition; a form of thought that can only take place through the act of writing. He thereby refers to Bernard Stiegler, who explains technology more generally as exteriorised cognition. Therefore, Stewart's account of enaction is not at odds with views of cognition that are extended.

Stiegler has written extensively about technology as an exteriorisation of memory. Stiegler uses the Greek term *hypomnesis* for the technical exteriorisation of memory (Stiegler, 2007; 2010). This term can be traced back to Plato and was used as an antonym for *anamnesis*, which is recollection through human or natural memory. Stiegler argues that we favour the virtue of anamnesis, but that we cannot do without hypomnesis. They are forces at work in what he refers to as a political question, for which he uses the Greek *pharmakon*, a word that expresses a poison that is also a cure. The reliance on memory aids, such as hand-written notes or reminders in digital devices, causes the gradual loss of the ability to remember without such aids. The increased potential that comes with exteriorising cognitive functions has a cost in a reduced ability to perform these functions organically.

Stiegler also explains that this dependence on technology is not a recent development, but is something that can be traced back to protohuman fossils from two million years ago. "Human memory", he writes therefore, "is originally exteriorized, which means it is technical from the start" (Stiegler, 2010, p. 67). There are however important differences in how this has played out over the course of history, especially in more recent times.

The technology of writing, he explains, is one that is reciprocal. If one is able to read, one can write as well and vice versa. If we are literate, we can be senders and receivers, producers and consumers of external memory. Stiegler calls this reciprocal condition *associated*.

Industrialisation has led to a dissociated condition that can be observed for example in broadcast media such as television, where the production of exteriorised memory is separated from its consumption. That imbalance, according to Stiegler, has a

profound impact on individuals and on society, but is adjusted with the proliferation of the internet:

**[T]he Internet age is an age of hypomnesia constituting itself as an *associated* technical milieu. It marks the end of the era of dissociated milieus - the escape from milieus that separate the functions of producers and consumers, deprive both of their knowledge, and consequently strip their capacity to participate in the socialization of the world through its transformation. (p. 83)**

Stiegler claims here that the ability to be both producers and consumers using the digital technologies that the Internet provides, marks a new era after a period where radio, television and written media were the predominant source of shared external memory. Stiegler's agenda might be one of social action (Fayat, 2010), but his reading of the significance of technology seems particularly useful in specifying the cognitive relation with technology, a relation that is a condition of life according to Stiegler. Despite critique on some aspects of Stiegler's work, James Revely and Michael Peters (2016) and Kåre Poulsgaard (2017) have shown how Stiegler can complement enactive views of cognition. Where Stiegler is specific about the relation between the human mind and technology, he lacks the rigorous framework for cognition that is provided by philosophy of mind (Poulsgaard, 2017). Poulsgaard in particular applies Stiegler's concepts of *grammatisation* (the discretisation of behaviour and thought) and *epiphylogenetic memory* (a third layer of memory in technics, after personal memory and biological evolutionary memory) to contemporary architectural design, and explains that

**we cannot escape the deep historical and transformative influence of technics as little as we can escape the evolutionary history of our species. They inextricably entwine; technics is a constantly evolving prosthesis for the creative extension of our embodied and imaginative abilities, including the ability to anticipate (design) and implement (fabricate) different futures. (p. 6)**

Poulsgaard continues to bring computational architectural design and digital fabrication within the framework of cognitive exteriorisation and demonstrates how computer code and robotic manufacturing are instances of grammatisation that form external and transferrable memory.

## 2.3 Dynamic Built Environment

The built environment is widely understood to be the structures made by humans to support their day-to-day living (Built Environment, n.d.-a; Built Environment, n.d.-b; Built Environment, n.d.-c). The built environment includes, for example, transport systems such as roads, railways and bridges, but also power plants, parks and buildings. The built and the natural environment are not necessarily separated topographic areas, but may overlap and have ambiguous features such as conserved natural areas or growing architectural structures. As a subset of the built environment, the thesis implicitly concerns itself with inhabitable structures. However, it does not, by necessity, exclude other types of structures, and will occasionally refer to works that are not inhabitable. The perspective is further that the built environment is not a given condition, but a dynamic composition subject to processes of design, construction, maintenance and use.

Such dynamics work at different time scales. Referring to the built environment as dynamic may mean buildings being constructed and demolished, changing the environment over decades, too slowly to experience as change. The decay of buildings due to weather and use, and processes of ongoing maintenance work on a more rapid time scale of years and months. These more rapid changes are noticeable, but not necessarily experienceable. Even faster dynamics unfold in experience time and are due to an occupant's movements around and through a building, or through explicit movements of the building itself. This is the time scale of interest in this study, as it concerns change that can be perceived.

As Kari Jormakka has often reminded us, it was Père Prosper Enfantin in 1832 who proclaimed that "Architecture as a theory of construction is an incomplete art: the notion of mobility, of movement, is lacking in it" (e.g., Jormakka, 2002). To some extent, this could still be argued today, but movement is not absent in architectural discourse and practice. For example, Jules Moloney sets out the different ways in which movement has featured in architectural design and theory. One way is that buildings transform due to their occupation, and another that movement is perceived by occupants as they move through the building. He also mentions the changes in light and humidity that cause optical effects that can be experienced as movement. Further, architecture has employed certain geometry and organisation that represents dynamics. Design also relies on dynamic techniques such as geometric transformations and animation (Moloney, 2011). And besides all those interpretations of movement, there is actual movement: physical movement of the building that is sometimes referred to as *kinetic architecture*.

This section has five subsections that address movements of the built environment. The first subsection turns to human movement in buildings and how it has played a role in otherwise static architecture. The second subsection acknowledges the representation of movement as a form of dynamics in architecture. The third subsection addresses virtual movement, especially in digital design, and highlights three potentials of actualising





2.10 Charles Garnier, Opéra Garnier.

such virtual movement. The fourth subsection deals with actual movement in kinetic architecture and looks at kinetic art for a refinement of movement itself. The fifth subsection positions this research in terms of movement, and presents three qualifiers in order to identify *structured movement*.

## 2.3.1 Human Movement

Through time, movement has played an important role in architecture generally. The movement of people through buildings and their expected spatial experience have almost certainly influenced the design of early buildings from antiquity and many buildings that followed. Peter Blundell Jones explores such perceived movement throughout history in a collection of essays (2015). As he finds, early authors such as Vitruvius hardly mention such movement explicitly (however, actual movement is part of chapters IX on timekeeping, and X on machine building), something that Blundell Jones attributes to the well-established typologies that existed at that time, and that everyone knew how to use. In contrast, Blundell Jones presents the writing by the architect Charles Garnier about his Opéra in Paris from 1875, *Le théâtre* (figure 2.10). The opera is a highly dynamic building, a prime example of the Beaux-Arts style, and Garnier has written about it in detail. In particular, the movement of people through the building has been addressed, not just in terms of circulation, but to establish a social ritual tied to the experience of attending a performance at the opera. Blundell Jones provides a translation of a section dealing with the staircases in the opera that demonstrates how form is related to movement of people:

**One normally walks perpendicular to the nose of the steps, so on arrival at the intermediate landing one has brusquely to change direction. It is therefore essential to give the steps gentle curves that lead naturally in the direction of the flights. (p. 34)**



2.11 Basilica of Sainte-Marie-Madeleine in Vézelay.

A critical engagement with movement can also be observed in religious buildings such as the Basilica of Sainte-Marie-Madeleine in Vézelay (figure 2.11), which was built in the Romanesque style through the 11th and 12th century. The floor plan was orchestrated to progress visitors through the building. The narthex, for example, a porch on the Western side of the building where people entered, was a space intended for pilgrims to prepare themselves for entering the holy space of the basilica. The sculptures in the narthex above the entrance to the nave and on the northern and southern side allude to that. As such, a processional route was formed aligned with the liturgy and the associated traditions and rituals. Church historian Richard Kieckhefer describes the longitudinal space of the basilica as a processional space, a space of kinetic dynamism that can mark transitions in the liturgy and that “permits clergy and congregation to [...] relate to each other in shifting patterns as worship progresses” (Kieckhefer, 2008, p. 25). The space is dynamically used to follow the patterns of worship but also invites movement through the positioning of the entrance and

important markers such as the altar. And the artwork such as the stained glass and other iconography, depict scenes or processions towards a sacred place in the church (Kieckhefer, 2008).

As a standard work of the modern era, the *Villa Savoye* (1931) in Poissy by Le Corbusier has epitomised the *promenade architecturale* as a spatial device for movement (figure 2.12). After arriving at the villa by car, following the curve of the lower volume and parking under the main volume, one enters the building. A ramp awaits, inviting visitors to take the journey up, first to the main volume, a hanging garden, and then on to the roof terrace, which provides a framed view of the landscape. Le Courbusier wrote about a similar experience in *Maison la Roche* from 1925: “You enter: the architectural spectacle at once offers itself to the eye. You follow an itinerary and the perspectives develop with great variety, developing a play of light on the walls or making pools of shadow” (JeanneretLe Corbusier, 1937, p. 60). Writing about the architectural promenade, Flora Samuel explains the tension between Le Corbusier’s resolve to create prescriptive frameworks for peoples’ lives (*machines à habiter*) on the one hand, and on the other, a desire for them, within the framework, to live out their own lives (Samuel, 2015; Samuel & Jones, 2012).



2.12 Le Corbusier, Villa Savoye.

A key interest of Le Corbusier, she explains, was the relation between the personal and the collective. The promenade offers multiple subjective viewpoints of the building: “The promenade enables the visitor to make new and individual sense of the information presented by the building” (Samuel, 2015, p. 45). Art historian David Joselit qualifies the promenade as a *format*, a “dynamic mechanism for aggregating content” (Joselit, 2013, p. 55). A format is not so much about the production of new content, but rather the “retrieval in intelligible patterns through acts of *reframing, capturing, reiterating, and documenting*” (p. 56). He argues that the architectural promenade is a format that spatially organises a population of images, of viewpoints that are being reframed based on the position of the spectator.



2.13 Walter Gropius, Bauhaus Building in Dessau.

## 2.3.2 Representation of Movement

In describing the Bauhaus complex by Walter Gropius (figure 2.13), the architecture critic Sigfried Giedion wrote in *Space, Time and Architecture* that the use of glass brought forth a dematerialising quality of the blocks of which the boundaries could not be clearly identified (1959). Due to the complexity of the building, it could not be perceived in a single view.



2.14 Zaha Hadid, The Hague Villas, Spiral House.

The ground plan lacks all tendency to contract inward upon itself; it expands, on the contrary, and reaches out over the ground. In outline it resembles one of those fireworks called “pinwheels,” with three hooked arms extending from a center [...]. The impression one receives from it is similar to that produced by the glassed staircase in Gropius’ exhibition building of 1914: it suggests a movement in space that has been seized and held. (p. 493)

Patrick Schumacher writes about an architecture of movement, and asks: “Is there an alternative tradition, an alternative paradigm of space or at least the theoretical possibility of defining space through movement alone” (P. Schumacher, 1996). Schumacher refers to movement, not as actual physical movement, but as an expression of movement captured in form, exemplified by Zaha Hadid’s design *The Hague Villas, Spiral House* (1991) (figure 2.14).

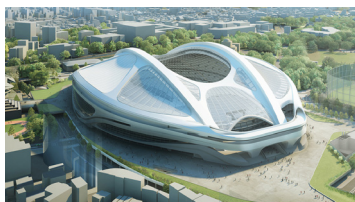

2.15 ZHA, Tokyo Olympic Stadium proposal with retractable roof.

Of course, better known as the protagonist of a Parametric Style, Schumacher proclaimed his Parametricist Manifesto at the 2008 Biennale in Venice (P. Schumacher, 2008). In the manifesto, five agendas are proposed to push the style of Parametricism further, one of which is Parametric Responsiveness, of which he says:

**We propose that urban and architectural (interior) environments can be designed with an inbuilt kinetic capacity that allows those environments to reconfigure and adapt themselves in response to the prevalent patterns of use and occupation. The real time registration of use-patterns produces the parameters that drive the real-time kinetic adaptation process. Cumulative registration of use patterns result in semi-permanent morphological transformations. The built environment acquires responsive agency at different time scales. (P. Schumacher, 2008 agenda 4)**

Schumacher’s professional architectural practice does not give much evidence of such kinetic movement however. The retractable roof that was projected for the Olympic stadium in Tokyo was cancelled with the entire project in 2015 (figure 2.15).

## 2.3.3 Design and Virtual Movement

Movement also plays an important role in architectural design. Just as Giedion mentioned the movement that had been seized and held in the staircases of Gropius’ Werkbund Exhibition Model Factory, many contemporary design processes are highly dynamic and come to be held in a *design freeze*. This design freeze may come with the production of specification documents, construction drawings, or only with the physical manifestation of the building. This process of freezing is not surprising given the practicalities and complexity of a building project and the inherently iterative design process that precedes it. But it is not just the iterative character of design that makes it dynamic, as is shown for example in the work of Frei Otto.



2.16 Frei Otto and Günther Behnisch, roof structure covering Olympiapark in Munich.

The experimental work of Frei Otto on lightweight structures, especially in the 1960s and 1970s during the early years of the Institut für Leichte Flächentragwerke, has him labelled by Mark Burry as a *proto-parametricist* (M. Burry, 2016). Otto's design thinking relied on the development of physical frameworks that would be informed by particular forces, rather than using a planned approach around predetermined form. This approach is highly dynamic and was regarded by Otto to be more flexible than what could be achieved using a computer. He would later say about this:

**The computer can only calculate what is already conceptually inside of it; you can only find what you look for in computers. Nevertheless, you can find what you haven't searched for with free experimentation. (Songel, 2010, p. 38)**

Otto's frameworks used gravity as an input, in a similar way as Gaudí famously did in his hanging models, to model with tension what would be inverted into compression structures (Liddell, 2015). The other ingenious experiments that have influenced architecture, including the tensile structure (figure 2.16) covering part of the Olympiapark in Munich (Otto, 2017), relied significantly on soap film to generate *minimal surface structures*, as described below. Minimal surface structures enjoy efficiencies as seen in nature, they avoid bending forces, and span large areas with sparse amounts of material (Beukers, 2005). For this reason, they are sometimes linked to sustainable or green architecture. The soap film experiments involved dipping a metal frame in a soap solution and experimenting with the resulting film. Areas of the film were, for example, pushed in or pulled out, or the boundary conditions were manipulated to transform the film. In Otto's words:

**It was very simple: we hang soap film, we let a string fall, we break the film remaining inside the string, and then a perfect circle is generated; afterwards, we take the string, we try to pull it outside, and then this minimum surface is generated. (Songel, 2010, p. 78)**

The dynamics of the process are complemented by the dynamics of the physical phenomenon itself. First, there is the activity on the surface that can be observed as changing or moving fields of colour. And second, the shape generated by soap film is an exact representation of the minimal surface, but due to evaporation of water, the soap film will eventually burst. In the context of Stuttgart's central station renovation, Otto explains the trade-off with more permanent models:

**Naturally, I can build this form with absolute precision using soap film. The form of soap film lasts only a few seconds before it disappears, so I can't show it to anyone. In this hexagonal mesh model, the form is not so exact but it is longer lasting; if I try to make something rigid or long lasting, then I cease to be exact. (p. 73)**

However, the dynamic quality of the soap films would inevitably be replaced by computer simulations and analysis that would increase the pace at which variations could be tested, but that would also give other dimensions to the dynamism of the design process.

Three accounts of movement provided by digital design models and their potential for spill over into the realised building will be highlighted: the inherent flexibility of parametric models and their potential to include simulation, the dynamic feedback between the physical environment and its digital representation, and animation as a design technique.

## Malleability of the Digital Model

Since the computer made its way into the design process of products, vehicles and buildings, specific software has been developed to support the design process. The acronym CAD for computer aided drafting, and later computer aided design has been applied to this branch of software. At least for use in the built environment, the software that was commercially available, initially mimicked the original processes of drafting; the interface resembling a drawing board to produce two-dimensional technical drawings. With developments over time, the possibilities the computer provided were adopted, and it became possible to automate certain drafting tasks, for example. A conceptual change came when building geometry was to be modelled in three dimensions and two-dimensional drawings would be computer generated at user-defined sections and elevations. The three-dimensional model became the core and could be regarded as a digital prototype, a precursor of the physical product (e.g., Kalay, 2004).

The use of computers would further change the way in which building models were regarded. The possibility to exchange and collaborate with digital information was key to a vision of a design process in which all parties would use a single model. Traditionally, every participating party in the design process would produce its own drawings, but a problem with this approach was that it led to many discrepancies and problems that would only be discovered during the construction phase and would be costly to resolve. Now referred to as the Building Information Model (BIM), the single model is becoming a reality in practice. Although the meaning of BIM is not universal, and plans for extensions are being constantly developed, in principle the BIM contains all the information required to make the building, including its geometry, materials, costs and how it is constructed. The practice of BIM is thought to go beyond the use of computer models, and has become a vision on collaboration in more general terms, revolving around a digital prototype that can perhaps be best characterised as a database of the future building (cf. Aish, 1986; Eastman, Teicholz, Sacks, & Liston, 2008; Van Nederveen & Tolman, 1992).

The collection of building information in a computer would also allow it, in principle, to be managed more flexibly. Designers and technicians could, for example, use parameters in modelling: rather than defining geometry with a set of fixed dimensions, as had generally been the case previously, the dimensions would be variable. For building objects, such as a beam or a floor, the thickness could be provisionally given then changed at a later stage

of the design. Where the undo-function would record a history that could be reversed, parametric modelling would allow for changes to be made without the consequential deletions of stepping back. On an abstract level, parametric modelling is more about modelling relations, or modelling topology, than about defining explicit geometry. Some parametric modelling paradigms resemble coding software in that geometric classes are instantiated using specific methods. Parametric models can therefore be said to be flexible models: models that change shape when parameters are varied. The digital prototype can be tweaked to perfection before it is frozen in a final state to be built (cf. Davis, 2013; Woodbury, 2010).

It is not just the flexibility of parametrisation that provides the digital model with dynamic qualities. Simulations of real-world processes are often employed by engineers to verify their designs. The range of phenomena that can be simulated in computer models and their resolution are seemingly ever increasing. In the context of building design, such phenomena include wind flow around buildings, daylight and electrical light in buildings, temperature and airflow, spreading of fire, acoustic performance, stress and deformation in materials, and occupant behaviours. Traditionally, such simulations would only be undertaken by specialist engineers and would take place on dedicated computer systems. The dynamics would only become visible after the simulation had ended, sometimes after days of computing. This has changed over the last decade as parametric modelling software such as Grasshopper has allowed the implementation of plugins that run specific simulations in real-time and can be operated by non-experts. The computers speeded up, allowing simulations to run on more available computers, and the applied algorithms changed, now sometimes providing less detail and certainty, but more immediate feedback. As these tools would now be used by architects, the feedback they generated would immediately lead to design updates. Consequently, the parametric model has become an aggregate model where the simulated forces of dynamic real-world processes inform the design, and where design iterations follow each other at a high pace (e.g., Negendahl, 2015).

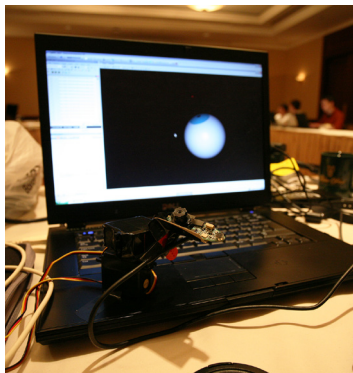

2.17 Face tracking camera and parametric model at Smartgeometry 2009.

## From Form-Fostering to Isomodel

At a workshop in Barcelona in 2010 organised by the Smartgeometry organisation, one group sought to experiment with the parametric model as a driver for external hardware. During the workshop in San Francisco in the previous year, the workshop champions had run experiments with a face-tracking camera robot and a *Wiimote* (a controller for Nintendo's Wii console) interacting with a parametric model that was set up in Microstation's *Generative Components*. The Wiimote could be regarded as an alternative input device that allowed for sketching in three dimensions. The camera, which was mounted on two servos and worked with an *OpenCV* library for face recognition, would physically turn to look individuals in the face. A feedback was established between the camera and the parametric model so that one could inform the other (figure 2.17). In subsequent papers, this process of generating form in parametric models using more than just digital parameters was called *form*

*fostering* (Salim, Mulder, & Burry, 2010a; 2011; Salim et al., 2010b). The experiments that followed during the 2010 workshop included positional tracking of markers, occupant movement sensing, Twitter-based modelling and light sensing to operate a kinetic roof. All these projects had in common that a physical reality was directly coupled to a parametric model. In some cases, sensors would act as input devices for the model, and in other cases, more elaborate feedback existed. The platforms that were used at the time were GC and a custom service that was called UbiMash (Salim, 2010). The parametric platform that was gaining traction at that time, and has overtaken Generative Components since as the go-to platform, is McNeel Grasshopper, for which Andy Payne wrote a plugin called Firefly that would interface with Arduino.

A consequence of coupling the parametric model with the physical world, as, shown at Smartgeometry, for example, is that not a virtual simulation, but real-world forces directly affect the model. For instance, a light sensor that measures the lux level in a room could inform a model parameter. And this parameter could consequently affect the layout of ceiling fixtures. The digital representation is affected by the actual external world. But it would not be inconceivable to remove the need for representation entirely, and to let physical objects in the world be their own representations. After a concrete wall that was modelled parametrically has been built, it could cease to exist digitally. There would be no need to maintain the geometry of the digital wall: its physical manifestation would have superseded it. The model in these terms, changes from being purely digital at the outset to becoming more physical over time. The traditional clear separation between design and modelling phase on the one hand and the built reality on the other, becomes more ambiguous.

To a certain extent, this idea has become a reality in building practice, although generally the representation remains as a *digital twin*. Information models such as BIMs are becoming re-used for the purpose of maintaining the built building. Many research projects measure building performance and feed it into digital representations of the building for analysis and optimisation. Building management systems also measure building performance, but often use an opaquer representation that is not necessarily linked to previous design models. Phil Ayres has coined the term *persistent modelling* to indicate an ongoing relation between the representation and the represented. If design, following Herbert Simon, is “aimed at changing existing situations into preferred ones” (Simon, 1996, p. 111), Ayres argues this should be an ongoing process, even after realisation of the design proposition (Ayres, 2012). An example of an implementation is the *isomodel* which updates along with the progression of construction and operation of a project. Jordan Brandt describes a curtain-wall facade project that starts with the creation of a digital model. After the primary structure of the building is constructed, a precise 3D scan is made of the connection points for the facade. Construction is never as exact as the ideal representation in the modelling environment, therefore the actual connection points vary. The scan now allows the representation to be updated with the actual positions of the anchoring points, allowing the facade to be installed with minimal adjustments (Brandt, 2012).

## Animation in Design

Animation in digital design has been explored in theory and practice by pioneering architect Greg Lynn. In his essay *Animate Form* (1998), Lynn sets out a theory of animation where form is generated by a set of dynamic forces, inscribing a potential for future use. Although he does not rule out actual movement of the resulting architecture, he certainly steers away from it and argues that virtual motion may be significantly richer: “Actual movement often involves a mechanical paradigm of multiple discrete positions, whereas virtual movement allows form to occupy a multiplicity of possible positions continuously with the same form” (p. 10). Animate design seeks to radically challenge the fundamental idea of an architecture of *stasis* and even of ideas of dynamics through human movement and through representations of movement, by evolving form that is many things simultaneously.

Lynn identifies a number of pillars that support the governing paradigm of stasis in architecture. First, there is an ingrained idea amongst architects that buildings are built for eternity. But, as he points out, most buildings have an expiry date, and architects should consider techniques for recycling and dismantling. Second, he addresses functionality and typology. Both are considered in a rigid way, as buildings have become highly specific in serving particular functions. Building typology, as it is traditionally regarded, is a generalisation of building form linked to functionality, and as such, supports a condition of stasis. Lynn provides an alternative in the digital “multi-type, or *performance envelope*” of which instances can be taken, and describes this as a parametrically controlled model of “relationships or expressions between a range of potentials” (p. 14). Therefore, a virtual model that yields beyond the mere digital, and is loaded with potential. A third aspect is the weight that is given to gravity as a vertical downward force and the resulting verticality of buildings. With new construction materials and techniques, other forces (such as horizontal loads from wind and earthquakes) become just as dominant though the conviction remains. An alternative view on gravity, such as Newton’s relative attraction of masses in space, allows for an understanding of gravity as a dynamic equilibrium of active forces and motions. Lynn writes:

**In the case of a more complex concept of gravity, mutual attraction generates motion; stability is the ordering of motion into rhythmic phases. In the simple, static model of gravity, motion is eliminated at the beginning. In the complex, stable model of gravity, motion is an ordering principle. (pp. 14-15)**

With such a dynamic understanding of the fundamental processes underlying his architecture, it seems surprising that he has resisted the idea of kinetic buildings for so long. But he may simply not have been convinced by the available technology that actual movement could do justice to the type of dynamics that he was applying in the digital models and in the production of physical form. One of the aspects that makes Lynn’s account so relevant for this study, however, is his reversal from rejecting to embracing actual movement. In a short text from 2014 on his website, he writes: “Motion is currently being integrated into buildings at



an unprecedented scale and scope. [...] Twenty-five years ago I decided to focus on the PHENOMENAL motion of the digital design medium while dismissing LITERAL motion. Today, literal motion and its phenomenal partner seem worth returning to” (Lynn, 2014). A number of his projects, including *Room Vehicle (RV) Prototype* (2012), GITA (an autonomous suitcase, developed for Piaggio), as well as a teaching programme at UCLA dedicated to robotic architecture, attest to his commitment to actual movement and to addressing the dichotomy of digital dynamics versus the rigidity of built architectural work.

## 2.3.4 Actual Movement

From a study of the literature about actual movement in architecture, a wide range of terms emerges, related to notions of temporality, change, interaction and adaptation. Often, it is not necessary to look beyond the title of a publication to learn that architecture can be *ephemeral*, *convertible* or *in motion* (Graefe et al., 1972; Kronenburg, 1998; 2013a; M. Schumacher, Schaeffer, & Vogt, 2010; Schwartz-Clauss, 2002). That roofs are *retractable* (Ishii, 2000), tensegrity may be *actuated* (Sterk, 2003), pavilions *temporary* (Baker, 2014; Hill, 2016) and structures *deployable* (Adrover, 2015; Pellegrino, 2001).

The term *kinetic architecture* has been used to refer to different kinds of moving buildings, and was the title of the seminal book by William Zuk and Roger Clark (Zuk & Clark, 1970). Their use of the term was not the first, but their publication came at a time that saw rapid developments in technology that enabled to a certain extent, but mainly promised, the imminent rise of movable buildings. The work has become a key reference, and marks an important point in the historic development of movable architecture. Chris Salter writes that the book’s relevance lay in providing for a generation of buildings, the key frameworks that fused technology, sociology and biology (Salter, 2010).

Various efforts have been made to classify architecture that is movable. For example, Zuk and Clark organised kinetic architecture into eight categories: (1) architecture that is static, but kinetically controlled, (2) that is dynamically self-erecting, (3) that has kinetic components, (4) is reversible, (5) incremental, (6) deformable, (7) mobile and (8) disposable. Most of these categories refer to movement that falls outside the scope of actual movement relevant for this thesis, because the movement cannot be experienced (category 1 and 5), or does not occur in the use stage of the building (category 2, 4 and 8). Architecture that is mobile (category 7) can generally also not be experienced as moving, as it is not occupied while it moves. Exceptions are boat houses and space stations. The categories of interest are those with kinetic components and deformable architecture (categories 3 and 6). Examples in those categories display significant transformative effects achieved through movement of building components.

A series of books by Robert Kronenburg examines buildings as *transportable*, *portable*, *in motion* and *flexible* (Kronenburg, 2003; 2007; 2013b; Kronenburg & Klassen, 2006). The first three of these publications deal with the movement of whole buildings relative to the environment, either as temporary buildings that travel or as vehicles (categories 4 and 7 in Zuk and Clark). In *Flexible: Architecture that Responds to Change*, Kronenburg explores explicitly the movements of buildings relative to themselves, organised in categories of buildings that adapt, transform, move or interact.

Michael Fox and Miles Kemp describe kinetic architecture along the theme of interaction. *Interactive Architecture* dates from 2009, but was recently republished with up-to-date references (2016). The publication builds a framework for understanding and analysing interaction in a building context, and provides an overview of the technologies to support it. They identify three types of kinetic systems at architectural scale that are either embedded, deployable or dynamic. The three types refer to moving systems that constitute the whole building in the use state, systems that facilitate erecting and dismantling of the building, and kinetic sub-systems such as facades or roofs.

Jules Moloney, in *Designing Kinetics for Architectural Facades* (2011), focusses on the building envelope to develop a strategy for the design of its kinetics. Moloney identifies four underlying themes for the design of kinetic systems in contemporary architectural discourse: (1) *indeterminacy*, (2) *functional expression*, (3) *intelligence* and (4) *dynamic structure*.

Indeterminacy, he writes, is related to kinetics that are designed as systems, but their actual behaviour, or the realisation of movement is left to chance because it is driven by external factors, such as the weather. In his quest for a kinetic morphology, Moloney wonders if the recurring interest in indeterminacy challenges his study, but concludes such kinetic projects

**still require the parameters of this interaction to be designed. There may be indeterminacy at the level of data sampling, but the resultant kinetic is moderated through control systems and tectonics that typically produce a consistency (note the repeated reference to wave and ripple motion, for example). (p. 27)**

The themes of functional expression and intelligence are both linked to the agenda of environmental performance. The first is manifested abundantly in active sun-shading systems that are typically either placed inside the facade, or attached to the outside of a building. Intelligence in this context is characterised as traditional computational models that take input, process data and produce output, with a learning function that considers a history of earlier events. The fourth theme, dynamic structure, entails movement at the structural level of the building, meaning movement of the load-bearing elements. Moloney does not discuss this in detail, because it is outside the scope of his work, but this theme is closely related to what Zuk and Clark call deformable (category 6) and Fox's category of embedded systems.

Adaptation was the key reason for Zuk and Clark to discuss kinetic architecture. Socrates Yiannoudes provides a thorough overview of buildings that change along this theme in *Architecture and Adaptation* (2016a). He sketches a historic perspective starting with the cybernetic movement in the 1940s before exploring, from different perspectives, the implications for occupants of architecture that is *interactive or intelligent*.

*Architecture of Change* was the term Branko Kolarevic used, first in a paper (Kolarevic, 2009), and more recently in an overview with Vera Parlac (Kolarevic & Parlac, 2015). The overview does not so much categorise movement, but unpacks the temporal aspect of architecture through a series of essays. Kolarevic's introduction is a short history of actual movement in architecture, arguing for the "need to go beyond the current fascination with mechatronics and explore what change means in architecture and how it is manifested" (Kolarevic, 2015, p. 15). But Kolarevic's call for action falls short of a pragmatic research agenda. Although the rest of the chapters explore aspects of change in architecture in some depth, little guidance is provided to form a coherent picture of an emerging field.

Finally, Chris Salter's *Entangled* (2010) sketches a technological overview of performance art, including the overlap with architecture, and integrates the brand of performative architecture as it was outlined by Kolarevic (2005). Salter explains the role of movement in architecture at the start of the 19th century and its revisiting at the end of the 1960s. He highlights the relation between performance art and architecture: "Architecture seems to have historically needed the theater to assist in pushing conceptual and structural boundaries - to practice scenography on the stage in order to carry it over into the urban wild" (Salter, 2010, p. 84). In terms of the possibilities of movement in architecture, this becomes evident in the transfer of stage technologies and scenography to architecture through for example industry that works on the borderline of these disciplines such as United Visual Artists, Stage One, TAIT and Disney.

## Movement on Its Own Terms

In *Designing the Dynamic* (J. Burry, 2013), a publication around a workshop organised at RMIT in Melbourne in 2011, Jane Burry wonders why designers have not engaged with the dynamic processes that inform our building designs in the same manner as with the constant force of gravity:

**Throughout the twentieth century there are many examples of 'structural artists', [...] who provide analog modelling as well as analytical answers to linking static behaviour of structures to the gravitational forces acting on them. In this respect many virtuosos spring to mind: Antoni Gaudí, Félix Candela, Heinz Isler, Eduardo Torroja, Pier Nervi, Frei Otto, and the**

list continues. But where are the elegant models that link architectural behaviour in the same way to thermodynamics or fluid mechanics? (p. 12)

This historic deficiency of dynamic design processes is perhaps reflected in the limited attention and secondary role that seem to be given to movement in architecture. Jules Moloney has observed that much of the literature available, and some of the designers of kinetic architecture, are not particularly invested in the manifestation of motion itself (Moloney, 2011). Movement, it seems, has to serve a purpose. This purpose may be utilitarian, aesthetic, or it may be to create conditions that are responsive, interactive, adaptive or performative. Whatever the purpose, movement is subsequently regarded on those terms. In this thesis, in the prototyping process and in the analysis of works in the following chapters, movement is approached on its own terms. Movement is taken as the starting point and as a constitutive element of the architecture it is part of. This is not to dismiss the context in which movement unfolds. Indeed, considering movement as both a phenomenon in itself and in service of some other purpose, provides the beautiful complexity that makes kinetic architecture so intriguing.

The lack of engagement with movement itself is not universal, however. An edition of a series of books published by the Institut für leichte Flächentragwerke (IL), *IL 5 Convertible Roofs* (Graefe et al., 1972), provides design guidance, a richly illustrated overview of movable roof typologies, and classifies movement types. Roofs

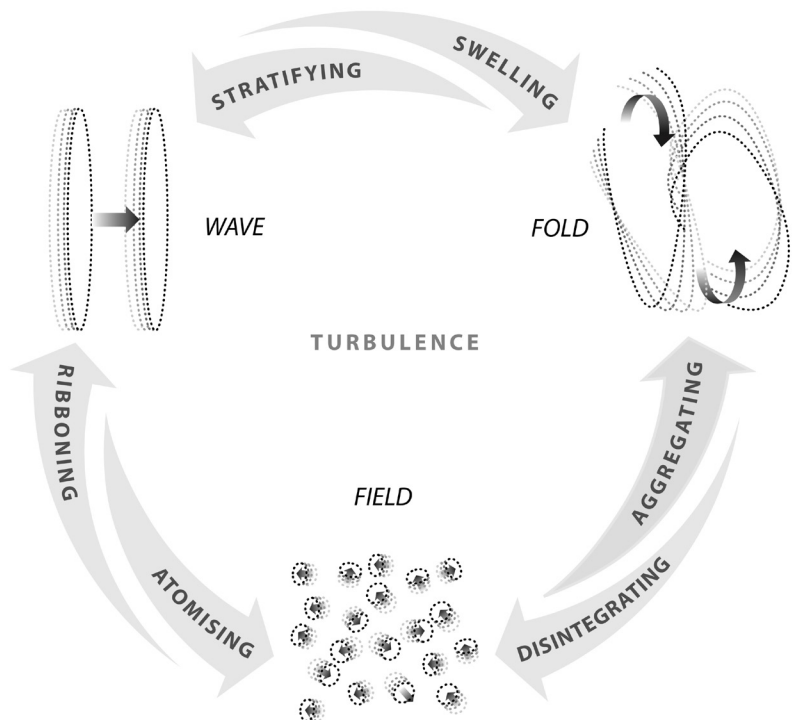

of fabric structures, for example, can either be bunching, rolling, sliding, folding or rotating. Roof panels can be sliding, folding or rotating. Each of these movement types is further specified by directionality: parallel, central, circular or peripheral. Detailed analysis of examples, from both design prototypes and built projects, follows later in the book. In a similar vein, the more recent *Move* (M. Schumacher et al., 2010) provides an overview of technology, and a wealth of examples of kinetic architecture. The examples are illustrated with analytic drawings, and categorised by their building parts that either swivel, rotate, flap, slide, fold, expand and contract, gather and roll up, or inflate.

Tracing precedents in kinetic art, Moloney develops George Rickey's morphological analogy of a ship at sea that pitches, rolls, falls, rises, yaws and sheers (Moloney, 2011). Rather than looking at the ship, as Rickey did, Moloney decides the sea is the better analogy for his specific interest in building facades, and proposes the terms swell, eddy, wave, ripple, chop and peak as nomenclature to describe movement. From a series of experiments conducted on screen, however, it seems that these terms are not satisfactory. Ultimately, he proposes three primary movement types that he refers to as *states*, and a series of *state transitions*. A diagram, shown in figure 2.18, summarises the various conditions of state change: a circular form suggesting a certain continuity, with the three main states at 120° angles, named *fold*, *field* and *wave*. The state transitions are directional, and therefore there are six: *disintegrating* and *aggregating*, *ribboning* and *atomising*, *swelling* and *stratifying*. The compound state in the centre of the diagram, as a mix of the three simple states, is *turbulence*.

## Art, Not Architecture

Although architecture has seen a period of intense interest in movement, roughly overlapping with the spike of interest in kinetic art from the 1950s until the 1970s, the agenda has differed from that in the visual arts, and the physical production of buildings that move has largely failed to materialise. The latter could be explained by the technical limitations or the perceived limitations surrounding mechanical systems. Such limitations had previously held back the development of kinetic art. Frank Popper describes Naum Gabo's *Virtual kinetic volume* (1920) as the first work of art that applies three-dimensional movement, and that was the result of a radical position on movement in art that was also expressed in Gabo's *Realist Manifesto*. But apart from some drawings in later years, Gabo did not follow up with other kinetic works. According to Popper "he considered that the motor was an encumbrance" and future technology had greater promise. "It was purely for technical reasons, he insisted, that he made no further investigations into real movement" (Popper, 1968, p. 125). Years later, in 1998, a similar argument was made by Greg Lynn. Lynn also stopped short of producing actual movement because he was dissatisfied with the limitations of building technology of the day (Lynn, 1998).

Architecture imposes different constraints on its production than much of the visual arts. The laws of physics prevent most mechanisms from simply scaling up in size, meaning that the elaborate mechanisms that drive scale models or kinetic installations require professional engineering for implementation at the larger building scale. Much of the experimental work in kinetic art has been produced in a makeshift manner (this was suggested in communication with Tine Colstrup, curator of Eye Attack exhibition in Louisiana museum, Denmark in 2016), and this type of experimentation is generally not possible at an architectural scale beyond prototypes. Thereby, the construction of buildings is typically regulated for reasons of safety, which limits the possibility for free experimentation.

As Moloney has found, despite the differences, tracing the development of movement in the visual arts can provide insights relevant for architecture. Artists working with movement, especially around the period of New Tendencies (the late 1950s until the early 1970s), have explored movement in itself and the effect of movement on the observer through the production of a considerable body of work that has been exhibited widely.

## The Art of Movement

George Rickey, himself an artist devoted to kinetic art, wrote an essay for Art Journal *The Morphology of Movement* (1963). It was later included in Kepes' overview *The Nature and Art of Motion* (1965). In the essay, Rickey traces the history of movement in the arts, identifies how movement has been explored and sets out a vision for kinetic art. Adding to the appeal of the essay, is its rich illustration with visual and textual examples. Rickey identified six directions that artists took to explore movement, all explained clearly with diagrams and photos. He first lists two directions based on visual phenomena, where movement appears, for example, as moiré patterns, or where movement transforms how something looks, as with the spokes of a turning wheel. The third direction, "*Movable*" works, covers pieces where the observer makes changes to the composition, and in the fourth direction, *Machines*, this is done by motors. Rickey is critical of this latter category:

**The power of a motor has been used to make diverting in motion what is dull and meaningless while at rest. Once the cycle of motion repeats itself a more emphatic stasis sets in, for the motion itself is not designed. This type of kinetic assemblage is the most common, the most captivating (for the public), and the least significant. (Rickey, 1963, p. 223)**

*Light play*, the fifth direction, is the effect of lights and shadows thrown and reflected by moving elements. Finally, "*Movement itself*" is the group of works that attempt to make "a significant visual statement" through movement: "Their movement is as intrinsic as that of a gramophone record or an airplane in flight; without it the object would be something else" (p. 224).

Rickey then goes on to set out how the creation of Form through movement in the visual arts is to be realised and makes connections to the establishment of other movements in the arts, such as Cubism and Expressionism. It has taken decades for those movements to take hold, after a gifted inventor initially provided the base for others to refine their skills and develop it further. At the time of writing, Rickey notes, many attempting to create kinetic art were stuck in the *discovery* phase, whereas for a mature practice, *creation* and *invention* are required. Kinetic art, he writes, “must not only embody movement itself, but also a component of chance, a machine aesthetic rather than Dada, and a high level of technical accomplishment” (p. 231).

Rickey’s text is an alluring plea for the development of a new movement in the visual arts. The criteria he defines definitely apply to his own work of kinetic sculptures that are moved by the wind. His sculptures, on display in public and private squares the world over, embody movement in the clearest sense. The key elements in most of his sculptures are moving objects that defy gravity and move in unexpected ways. Not only are the elements set in motion by unpredictable gusts of wind, many of them are constructed as multiple coupled pendulum systems that are, in themselves, characterised by chaotic kinetic behaviour.

## Movement at the Right Time?

Although sculptors like Rickey have continued to develop their practice after the 1970s, kinetic art generally has seen a sharp decline after those years. Writing about Guy Brett’s Force Fields exhibition, Yves-Alain Bois attributes that decline to the awarding of the Grand Prize at the Venice biennale to “mediocre” artists Julio Le Parc in 1966 and Nicolas Schöffer in 1968. The mass production of kinetic gadgetry and kitsch such as the 1970s lava lamp, has also done nothing to enhance the reputation of kinetic art according to Bois (2000). This sentiment is echoed by Matthieu Poirier, who writes:

**We have forgotten just how radical [kinetic art] was originally considered to be. That was before it was absorbed by the applied art industry, which converted it into catchy decorative or commercial designs. [...] The most radical and critical discoveries [...] were soon drowned in a veritable aesthetic soup, in a slick, scintillating parade of gimmickry, ranging from fashion shows to window displays. (Poirier, 2016, p. 68)**

Susan Best writes that the depreciation of kinetic art to kitsch does not apply to the South American context (Best, 2012). In the 2012 exhibition that she curated, *Vibration, Vibração, Vibración: Latin American Kinetic Art of the 1960s and 70s*, at the Power Collection, University of Sydney, she shows that kinetic art from Venezuela, Brazil and Argentina dealt with different concerns than those in Europe and the US. As the South American countries that were open to European influence, artists there, such as Gertrud Goldsmidt and Lygia Clark, were exposed to but reinterpreted the movements that

led to kinetic art, and their work consequently has not fallen prey to the association with cheap gadgetry.

Through exhibitions such as *Force Fields, Phases of the Kinetic* (2000), at MACBA in Barcelona and the Hayward Gallery in London, curated by Guy Brett; *Zero: Artists of a European Movement* (2006), at the Museum der Moderne in Salzburg; *Luce e Movimento* (2010) at the Signum Foundation in Venice, *Dynamo* (2013), at the Grand Palais in Paris, curated by Matthieu Poirier, and *Eye Attack* (2016) at Louisiana museum of modern art in Denmark, it seems that a re-evaluation of the European movement is underway. This is also evident in the renewed interest in the work of individuals such as Gianni Colombo from Gruppo T, whose work today is increasingly exhibited (Archivio Gianni Colombo, 2018).

Dedicated places, like the Kinetica Art museum in London (2006-2007) and its art fairs (2009-2014) that showcased contemporary work, also attest to renewed interest in kinetic art. The ubiquity of movement incorporated in contemporary media art suggests that movement has become part of the palette of artists working across a wide range of themes.

Whether movement in architecture is also due a revival remains to be seen. In the book *Kinetic Architecture* (Linn & Fortmeyer, 2014), its authors Charles Linn and Russell Fortmeyer voice some remarkable and slightly sobering thoughts:

**This is not a book about buildings that move. ... an architecture of movement, cities that walk, or buildings that flap their wings are provocations more than anything else. They reveal desire or hope or even technological prowess, but they aren't what interest us *any more* [emphasis added]. In many ways, they are diversions ... Literal movement is not an endgame that we care to investigate. (Linn & Fortmeyer, 2014, p. 8)**

As the examples in the book demonstrate, movement has become one of many possible interventions in modulating a building's energy flows. Perhaps, in a similar way as kinetics in art, movement in architecture has become part of the architect's repertoire of design solutions. It is more likely, however, that the occasional application of movement in a building design keeps the designing architects in what George Rickey called the *discovery phase*, of which he said "In art discovery is not enough" (Rickey, 1963, p. 229).

If movement is increasingly part of building design, it deserves the care to investigate. To focus on movement as an endgame, is to apply a filter that helps develop movement in isolation. That is not the same as advocating that all buildings should move in extraordinary ways, but the speculation allows us to investigate movement in a level of detail that is not feasible in regular building practice.



## 2.3.5 Identifying Structurised Movement

The introduction of this thesis states that movement of architecture in this research is employed as a lens. The previous sections have identified movement in a number of guises, spanning the phenomenological, the digital and the actual. Actual movement in architecture, or kinetic architecture, is still an overly-inclusive category for productive use in this thesis. Returning to the introduction, the centrality of movement is captured in the speculative quest for architecture made of movement. Therefore, the particular movement that we pursue is a constitutive movement, a movement that cannot be left out without changing what the building is.

An aspect to consider here is the perceptibility of movement. One of the key aspects of enactive cognition is the perception of the environment as a bodily process, and the experience of phenomena as they are encountered. Because of the relations that are drawn in this thesis between enactive modes of cognition and movement in architecture, it seems most relevant to investigate such movement that unfolds in ways that are in tune with the sensitivities of the human perceptive apparatus.

A threshold for sensory experience, like the measure of *just noticeable difference*, attributed to Gustav Theodor Fechner, could be used to quantitatively assess whether movement takes place at the right pace. In practical terms, the assessment can be made as a matter of judgement with little controversy, as the differences between works on the scale of perceptibility seem significant.



2.19 Baubotanik, Aussichtsturm am Lippeufer in Olfen, Germany. Detail.

Of the extremes, movement that is too fast to be perceived is hard to imagine in a building context. Large building parts typically have large inertia, and the approach to putting them in motion without causing material failure involves gentle accelerations and moderate movement speeds. On the level of the mechanism, however, movement could occur that is faster than the eye can perceive, for example the shaft rotation of a motor.

On the other hand, movement that is too slow to perceive directly could be related to weathering or biological growing. Projects such as those by the German practice Bureau Baubotanik, where trees are grown as structural elements (figure 2.19), or the bridges grown from *Ficus Elastica* aerial roots by the Khasi people of Meghalaya in India (Shankar, 2015), therefore fall outside the range of consideration.

Within the range of perceptibility, it should also be noted that perceived movement can be of different kinds. Movements could, for example, be perceived as the translation of a building part, or the alignment or misalignment of a series of elements. Movement can be perceived directly, or indirectly, for instance, in changes of intensity of light or sound. And variations in rhythm can be perceived as movement.

## Structured Movement

*Structured movement*, I propose, is a subset of movement encountered in kinetic architecture. The term seeks to address movement that can be said to form a critical aspect of a building in its architectural make-up. Movement of the structure, as it is meant here, refers to *structure* as defined by Maturana and Varela (Maturana & Varela, 1992). They define structure as “the components and relations that actually constitute a particular unity and make its organization real” (p. 47), where *organisation* is the abstract set of relations. Structure can therefore be understood as the concrete instantiation of the abstract organisation of something. *Structured* points at the fundamental relations that constitute the organisation, and indicates a concretisation that takes place in the realisation of a building. Structured movement, therefore, is fundamental in the abstract and realised in a concrete sense.

### STRUCTURED MOVEMENT

INTENTIONAL  
ACTUAL  
BEYOND UTILITY

In relation to the built environment, the term structure is loaded with meaning. It may refer to a building as a whole, or to the load-bearing structure that makes a building stand up. It could also refer to the composition of architecture—the patterns and relations between building elements. It may therefore be contentious to use such a similar term in the way that I propose. In support of its use, I put forward that the ambiguity that already exists in the use of *structure*, does not so much confuse as open up for other uses. Thereby, the reading of structure as composition is very close to the intended meaning. The form *structure* is not common and therefore suggests a distinct use case.

The fundamental nature of structured movement does not imply that a building has to move all the time. The potential for movement and the fulfilment of that promise at certain times may actualise the movement equally well. The *Hyperbody's Muscle for Non Standard Architectures* (2003), for example, was an inflated blob confined in a net of pneumatic actuators (see figure 2.5). The external and highly visible actuators set an expectation of movement. But without that movement becoming real, the blob would at best be a curious object. Structured movement also does not imply that the building needs to be mechatronically activated. Some buildings are driven by forces such as wind, water, or the people using the space. For example, Cantoni Crescenti's *Túnel* (2010), shown in figure 2.20, is a tunnel that tilts sideways and distorts locally with each step taken. But unless it does just that, it would merely be an unassuming series of metal frames in a row.

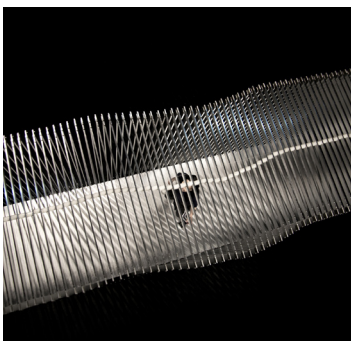

2.20 Cantoni Crescenti, Túnel.

To clarify the specific meaning of structured movement and to aid identification, three qualifiers have been established. The following subsections unpack structured movement as *intentional*, *realised*, and *beyond utility*.

## Intentional

The first hallmark of structured movement is that it refers to the physical movement of a building in its use stage, resulting from a deliberate act of design.

Most buildings feature at least some movable elements, if only a door to control access to the building. In fact, as Kari Jormakka writes, this is:

**Perhaps the most crucial function of all architecture. Neither a house nor a prison could function unless it were possible at times to open the spaces to some users and close them to others. Only very few kinds of architecture, such as the tomb and the monument, can sometimes dispense with actual movement. (Jormakka, 2002, p. 94)**

Doors, windows, escalators and elevators are all common and often necessary movable elements in buildings. Some buildings also have forms of movable shading and window cleaning installations, and depending on where one draws the line between the building and its interior, separation walls and furniture could count as moving architectural components. Apart from these visibly moving elements, buildings often contain systems that channel air and water and consist mainly of hidden movable parts. In themselves, all these movable elements are part of the design, for example, they facilitate entry, routing, daylighting and ventilation, but their movements are often arbitrary. Most hinged, sliding or revolving doors can move without altering the way that a building is used or experienced. Movement resulting from design implies the opposite, namely that the particular movement has a role to play in the architectural composition as a whole.



2.21 AL\_A, MPavilion 2015.

This view of movement further rules out one-off non-repeatable moves (for example in construction), accidental and other unintended movements. If floors or stairs or even whole bridges are under-designed, they might vibrate or sway due to the movements of walking people, but this is generally considered a design error. Extreme events such as storms and earthquakes might cause movement in buildings, and even though some buildings are deliberately made flexible to absorb the external forces from earthquakes (as a strategy to resisting them), this does not typically affect the building in its normal use stage. In contrast, AL\_A's *MPavilion* (2015) in Melbourne (figure 2.21), was designed with a roof so flexible that it would sway in the wind. The condition under the roof became a combination of carefully designed finishes with stochastic, nature-like, movements. Even though the exact movements could not have been exactly predicted, the movements are facilitated following a process of design.

## Actual

The second concern is that motion manifests itself as actual movement. Actual movement is distinguished from virtual movement, which either remains in the design stage, is perceived by the occupant but not physically there, or is animated through screens or lights, for example. Actual movement takes place as a physical transformation. As Rob Shields explains to Henri Bergson (Shields, 2003), *actual* may also refer to the future as a possibility:

**The concrete is an ‘actual real’ such as a taken-for-granted thing, an actualized idea and anything that embodies memories. It is the event, our everyday ‘now’. [...] The probable is an ‘actual possibility’ usually expressed mathematically, such as a percentage. (pp. 28-29)**

This seems particularly relevant for the experience of moving architecture that is not in motion continuously; it may still hold the promise of movement at a later stage. More practically, actual movement implies that the work in motion has been realised as a physical construct. There are many more examples of movement in architecture that remain representations in a design stage, special effects in film or virtual objects in video games, but all of those examples have never been subject to the physical environment to overcome the reality gap.

## Beyond Utility

A third aspect of structured movement is that it operates beyond utilitarian functionality. In that case, movement is not exempt from utilitarian qualities, but its deployment further serves aesthetic, transformative, cultural, or critical purposes.

2.22 OMA, Garage Museum of Contemporary Art. Folding art boards.

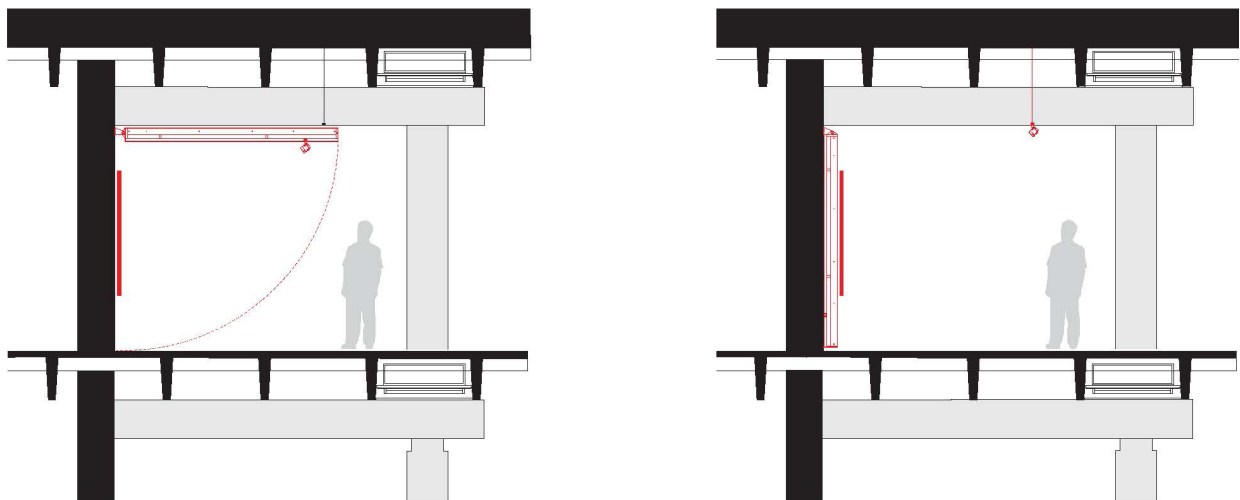

PANELS RAISED

PANEL LOWERED

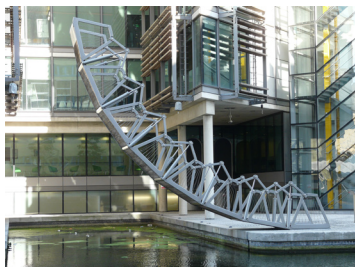

**2.23** Thomas Heatherwick, Rolling Bridge.

The moving floor (that was not realised) as part of the OMA's *Garage Museum of Contemporary Art* (2015) in Moscow would not just have been a giant freight lift for artworks, but a prominent exhibition platform that would give the space a different character every time it was repositioned. The movable exhibition boards (figure 2.22) in the museum serve a similar purpose; the positions of the boards set the space as a white cube gallery (boards down) or reveal the history of the building as a Soviet-era restaurant and long-derelict structure (boards up).

Thomas Heatherwick's *Rolling Bridge* (2004) beside the Paddington Basin in London (figure 2.23) is lowered as an uncurling fern leaf, rendering the functional operation of a movable bridge into a visual spectacle. Due to its position however, its movements are practically devoid of functional purpose: the inlet of the basin it crosses is so short it can be walked around with ease. The bridge's movements may therefore be understood as entertaining or inspiring or as an experiment testing a different movement typology and drive system for a movable bridge. Perhaps this project even questions the fundamental principles of a movable bridge by proposing a radically different typology.

On the other hand, the intricate movements of a telescope enclosure, such as those of the *VLT* in the Atacama Desert or the *GTC* on La Palma (figure 2.24), are there only to technically support the operations of the telescope it contains. And although some aesthetic qualities may be attributed to these moving structures, they do not touch on what the building fundamentally is.

**2.24** Enclosure of the Gran Telescopio Canarias on La Palma.





2.25 Paul Andreu, Charles-de-Gaulle airport, Terminal 1.



2.26 Richard Rogers, Lloyd's of London.

Clearly, some judgement is involved in making the distinction. For example, the general use of escalators in a London metro station is purely functional, and serves to move passengers efficiently between platforms and street level. The alternative stairs to use in case of escalator failure have the exact same functionality, albeit somewhat less efficient. In contrast, the use of escalators in Richard Rogers' *Lloyd's Building* (1986) in London not only serves a functional cause, but adds significantly to the high-tech character of the architecture (figure 2.26). The attention is drawn to the escalators, placed centrally in the atrium, and made transparent to highlight the internal mechanisms. What results during the busy morning, lunch and evening hours is a spectacle of movement. Similarly, the placement of escalators in Paul Andreu's futuristic *Charles de Gaulle Terminal 1* (1974) in Paris is intended to evoke a specific look and experience that defines the building (figure 2.25).

## Three Doors

In order to illustrate how structured movement can be identified, we could look at Santiago Calatrava's loading-bay doors for *Ernstings Warehouse* (1985). The warehouse is part of a distribution centre belonging to the German Ernstings family, textile retailers located in Coesfeld, Germany. Calatrava designed three loading-bay doors in the western facade, each measuring 13.5 m wide. The opening mechanism is a simple folding hinge, but the curved distribution of the hinge position along the 73 vertical slats comprising each door, causes the opening of the door to be a graceful performance that results in an arched canopy overhanging the entrance (figures 2.27 and 2.28). The transition of a flat vertical surface into a curved sculptural form is surprising in its simplicity and unfolds during the mundane functional process of opening or closing a door. The replacement of these doors with, for example, standard rolling overhead doors would likely still result in a functional warehouse, but the surprise and spectacle that make this building unique would certainly be lost. The carefully designed mechanism, its impact on the building and the possibility to witness the transformation, make this a good example of structured movement.

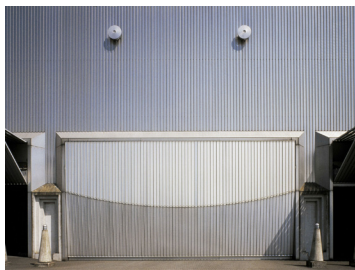

2.27 Santiago Calatrava, Ernstings Warehouse. Loading-bay door opening sequence.

2.28 Santiago Calatrava, Ernstings Warehouse.



## 2.4 Taking Stock

This conclusion highlights the key learnings from chapter 2 that lead into the following chapters. For each of the three sections in chapter 2 a summary is given of the key terms that were established.

In section 2.1, the cognitive built environment has been outlined as a context to which this thesis responds. The dominant approach in contemporary building design regarding cognitive buildings is firmly rooted in a computational paradigm. In order to open for other perspectives, five approaches have been described that demonstrate how cognition has more broadly been put to work in technology and architecture. These approaches have been described as junctures between significant influences.

The first juncture describes the development of computationalism through early ideas of artificial intelligence and psychology that influenced each other in such a way that the roles of biology and technology were reversed: the artificial computational process became the model for biological cognition.

The second juncture describes the development of artificial neural networks (ANNs), which were initially based on a physiological understanding of the brain. ANNs have developed in various directions for machine-learning applications, but also as simulation and recreation of a full human brain.

The cybernetic movement, as the third juncture, brought together ideas of human and machine cognition in a dynamic process theory. Through its dedication to hardware, cybernetics has been a productive force in architecture, leading to early efforts to produce intelligent buildings that would relate mutually to both the building and its occupants.

As a fourth juncture, embodied cognition is discussed in relation to robotics. Developments in robotics that radically departed from centralised, representational systems led to behaviours that emerged from a robot's interactions with its environment. This was seen as encouragement by early proponents of enactive cognition.

Swarm intelligence, the fifth juncture, is a biomimicking technology, inspired by the behaviour of large groups of animals. Its potential for the built environment has been recognised in the production of complex building components and in the emergence of a unifying intelligence by means of the decentralised and non-homogeneous components that make up a building.

All five approaches demonstrate how ideas of natural and technological cognition have influenced each other. The distinction between *strong* and *weak* artificial intelligence (AI) made by John Searle shines through all five approaches. Where the goal of those pursuing strong AI is to build systems that truly are intelligent minds, pursuers of weak AI promote systems that simulate intelligence and that may be used as a tool, for example, to study the mind. In that sense, the furthering of soft AI is a development



of both the technology and understanding of natural cognition. A parallel can be drawn with each of the five highlighted approaches where developments of the technology have influenced the thinking of the original (natural) systems on which they were based. If we extend the parallel further, we can see how talk of a cognitive built environment implies both the building technology and our understanding of the occupant.

In section 2.2, a position is taken regarding the enactive view of cognition, framed by three key concepts: *coupling*, *acting out* and *exteriorisation*. In doing so, the position is refined and loaded for analysis of movable architecture.

The concepts are preceded by the topic of representation, which is a contentious topic in philosophy of mind, where the existence of representations is no longer unequivocally accepted. Some argue that representations as symbolic or picture-like models in the mind are redundant because a world with infinite resolution is out there to perceive.

The first of the three concepts, coupling, explains how, in the enactive view, the organism is related to its environment. Coupling is not only a matter of direct perception and awareness of the moment, it also implies a history that has made the organism sensitive to its environment, an environment that results from the organism's physiology.

The second concept, acting out, explains the mechanism of perception as a purposeful activity. In order to perceive their environment, an organism has to actively move about. Sensations, the raw inputs for perception, fade away without movement, and movement is therefore a critical condition for cognition. The particular way that the physiology of the body allows an organism to move determines how perception unfolds.

The third concept, exteriorisation, explains how things external to the body and in particular considered as technics, are crucial for cognition. The entanglement with technology provides a particular memory and facilitates specific forms of thought. In order for this to be sustainable, the relation with technology should be associated, meaning that exteriorised thought can be both produced and consumed.

In section 2.3, a position on architectural movement is taken that involves searching for actual movement that defines architecture and that is further referred to as structured movement. In order for structured movement to become part of conscious experience, extremely slow movements are excluded. To help identify structured movement, three qualifiers are established as *intentional*, *actual*, and *beyond utility*.

The first qualifier is that such movement has been specifically designed as part of the building and does not deal with accidental movement in the use stage or one-off moves during construction.

The second qualifier is that the design was realised in order to actualise the movement. This distinguishes structured movement from virtual movement, and insists that it deals with the physical reality of the built environment.

The third qualifier states that structured movement provides more than utilitarian functionality. It does not rule out such a functionality, but the manifestation of movement should touch on some of the underlying design values, whether these are, for example, artistic, cultural, or critical.

After having developed a context, this chapter has outlined and sharpened the concepts to be employed in this thesis. The qualifiers of structured movement inform the prototyping process in chapter 3 and allow the selection of works described in chapter 4. The specification of the enactive view presented in this chapter has instrumentalised the view as a productive tool for critical analysis in chapter 5.



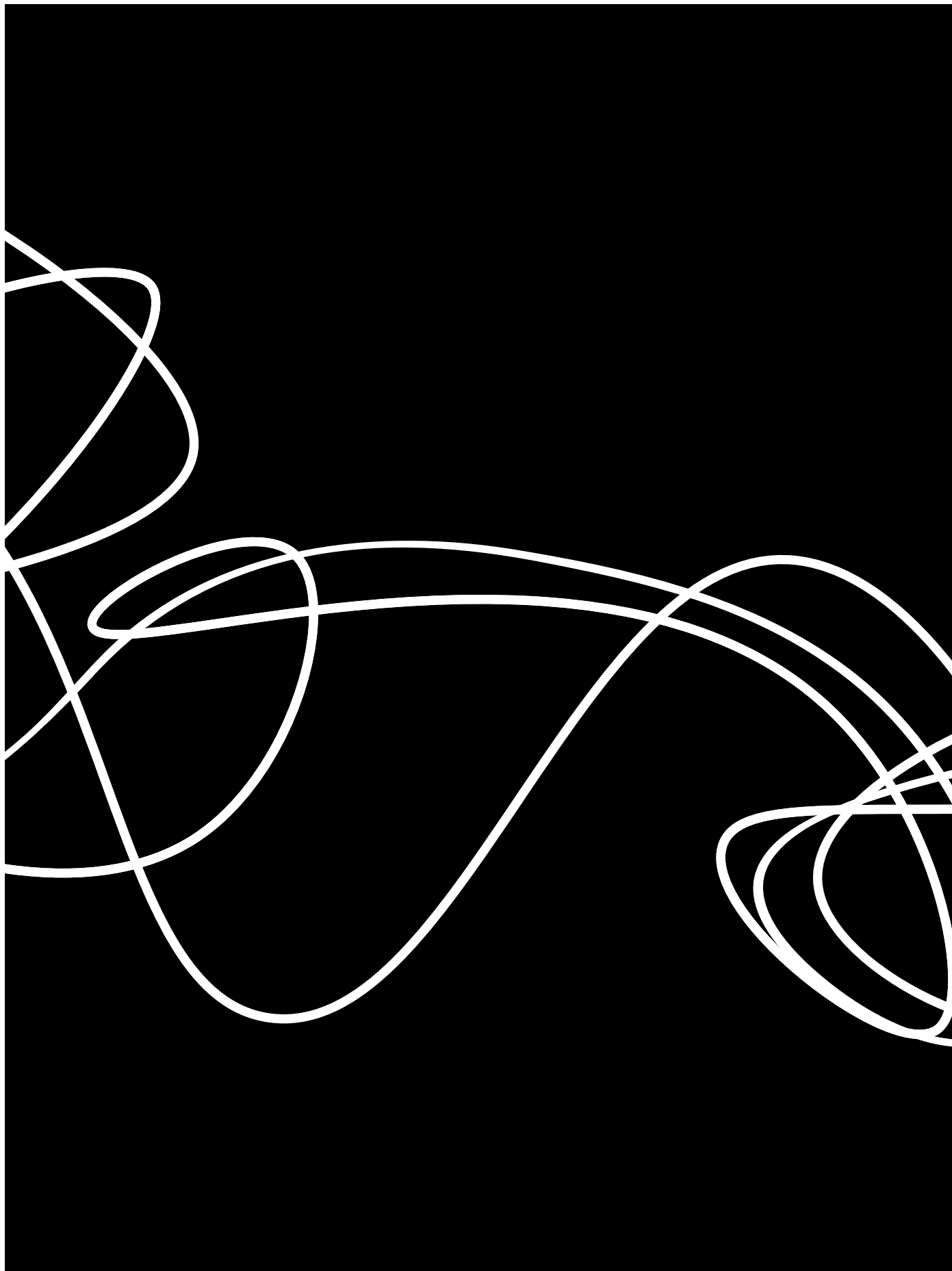

# 3.

# Prototyping

This chapter discusses the design and making of a research prototype—an architectural prototype that serves the structuring of thought in support of the research process. The prototyping process corresponds to one of the three intertwined threads in the triple squiggle that is presented in figure 1.8, and develops the vectors of movement and enactivism that have been set out in chapter 2. The process is unpacked in this chapter in three sections. Section 3.1 sets out the design approach and its objectives, and positions the research prototype as a tool for thinking. Section 3.2 provides a detailed description of the design considerations and the making process. Section 3.3 frames the prototyping activities as enactive processes.

In section 3.1, the prototyping process is introduced as a design environment to conduct research. The prototype is positioned as a tool for thinking that facilitates the exteriorisation of thought in a process similar to writing. The design process responds to a speculative position that situates movement as the central design concern.

Section 3.2 retraces the process of design and making that has been stretched along the other parts of the research, in order for it to inform and be informed by it. This retracing is done more or less chronologically, but is organised along a number of topics, or influences, that have shaped the process towards the final prototype. The rich descriptions are illustrated with visual documentation to paint a detailed picture of the process and significant steps in its progress. The descriptions clarify the significance of the qualifiers for structured movement that are set up in section 2.3.5.

Section 3.3 frames the prototyping processes in terms of Bernard Stiegler's philosophy on technics. His theory about memory as partly exteriorised involves a process of coding and decoding memory through technological means. The prototype as a tool for thinking, as introduced in section 3.1, can now, after the detailed description in section 3.2, be analysed in more detail as enactively exteriorised.

## 3.1 Research by Prototyping

The considerations and practical processes described in this chapter concern a type of installation that I refer to as a *research prototype*, by which I mean a prototype *for* research. This prototype guides and challenges the research by providing grounds for critical reflection. The process central to this chapter is therefore a prototyping process.

The prototyping in this research involves design and making, two subprocesses that have proven to be difficult to separate. In the first place, because design and making were conducted by the same person, causing feedback cycles to be short and direct, and in the second place because they both relied on digital processes that enable drawing and making to be similar activities. In prototyping here, making is absorbed in the design process, rendering prototyping a particular form of doing design.

As prototyping is conducted in the service of research, we could speak of research by prototyping, a special case of *research by design*. Christopher Frayling has referred to this research practice as *research through design*, asserting that the practice of design in itself provides the methods to conduct research (Frayling, 1993). Although in some places this form of research has been practiced for many years and a deep understanding has been built around it, over the last years it has more broadly received renewed attention, especially in disciplines where design is the primary practice, architecture included. Frayling, who was at the RCA when he wrote his seminal text, discussed both art and design, explaining that the process of research through these practices acts as a similar mechanism with similar concerns.

As Frayling has set out, the goal of research through design is the insight that is gained from doing design, rather than the actual design outcome. This would imply that the design and making of the artefact in my prototyping process, and not directly the artefact itself, are the key concerns of the research practice. In the prototyping process, however, the role of the artefact is multifaceted. In an essay about the role of the artefact in artistic research, Linda Candy and Ernest Edmonds write:

**The artefacts that practitioners create are an integral part of practice whether or not there is a formal research process. However, within research, the making process provides opportunities for reflection and evaluation. It is also an opportunity to generate research questions from the exploration that is a normal part of practice. (Candy & Edmonds, 2010, p. 123)**

Even though Candy and Edmonds, like Frayling, emphasise the process of design and making, they affirm the inseparability of artefact and process. The prototype as artefact holds significance also beyond enabling the process of its becoming. Analysing in this chapter the processes that it supports, I will pay particular attention to the prototype as the embodiment of exteriorised cognition, and extend that understanding from the prototype to architecture

more generally. The pretext to the analysis of the prototype is set out in the following subsection 3.1.1, where the prototype will be unpacked as a technology that aids thinking, similar to the technology of writing.

Positioning this research in the tradition of research by design is helpful because an increasing body of academic work is lending credibility to this approach (De Walsche & Komossa, 2016; cf. Fraser, 2013; Joost, Bredies, Christensen, Conradi, & Unteidig, 2016; Moloney, Smitheram, & Twose, 2015). But that same body of work is all but univocal about how such research is undertaken. My background as a design engineer is only partially helpful. It means, in my case, that I have gained skills for practicing design, but not for being reflective on it. My design experience has covered projects along a range of feasibility, but always with an intent for realisation. Even though some of those projects might be labelled speculative, they ultimately responded to *how to* questions—proposing a technological solution to a problem.

In my experience, design, especially early stage design, has often taken an intuitive path of trying solutions until *it seemed right*. Some design objectives would have been explicit and clear from the start, others would become more pronounced with time, and others still would only emerge during the process. Subsection 3.1.2 defines the design objectives for the prototype, and makes the distinction between objectives that were clear from the start, those that were latent, and those that transpired with time.

### 3.1.1 The Research Prototype as a Tool for Thinking

In a series of interviews with architects and building engineers, Jane Burry and Mark Burry have sought to clarify the multiple roles of the prototype in architectural and engineering practice (M. Burry & Burry, 2016). The core of the resulting book consists of fifty illustrated views of the role of the prototype in practice. In the introduction they write:

**The first question we asked was simply, ‘What is a prototype?’ In almost every one of the fifty practices we visited, there was a long pause—sometimes a very long pause—before a response was offered. Although we never received the same answer twice, a taxonomy of sorts gradually emerged. (p. 14)**

Their taxonomy is not meant to be understood as a rigid structure of mutually exclusive taxa, but serves to emphasise the variety of views they received in the survey. The groupings that have emerged capture particular views of the prototype. One view, for example, suggests that every building is a prototype, because it is the first of its kind. Lessons learnt from designing and building it can be applied to the design of the next building. Other views present the prototype as part of the process of delivering a building. Either by starting the creative process, by testing design ideas, testing the



performance of aspects of the building, or testing the fabrication and assembly. Intangible aspects such as workflow and design data can also be physically manifested in a prototype.

The grouping of prototyping as *A Tool for Thinking/Feeling* addresses most closely what the prototype signifies in the context of this research, and serves as a starting point for my own position. Jordi Truco and Sylvia Felipe from HYBRIDA in Barcelona discuss their understanding of prototyping as *A Tool for Thinking*: “Unless you understand prototyping as a process in which ideas and making inform one another,” believes Truco, “you will see only a product, not the opportunity to experiment and create something new” (M. Burry & Burry, 2016, p. 64).

## A Tool for Thinking

This understanding of *ideas* and *making* as dynamically informing each other was laid out by Michael Speaks in a series of articles and interviews in 2002 and 2003 (Speaks, 2002b; 2002a). Speaks writes about *design intelligence* as emerging from a new way of doing architecture that he observed in several young architecture firms at that time.

Such design intelligence is an opportune collating of information that cannot all be known to be true, but that collectively becomes a transformative force for innovation. In historical perspective, Speaks argues, such intelligence replaces the more encompassing views that were present in theory and philosophy before that. In his writing, Speaks emphasises the role of the prototype, not as a representation of the design objective, but rather as a form of production that drives change. “[T]he search for prototypes that solve specific problems has today been replaced by prototypes, scenarios, versions and spreadsheets that are instead used to innovate. The product is not so much the prototype as it is the innovations that occur as a result of thinking with and through the prototype.” (Speaks, 2002b, p. 6). The architecture firms that he refers to, “also view design as dynamical and nonlinear and not as a process with a beginning, middle and end. Accordingly, the relationship between thinking and doing becomes more and more blurred so that thinking becomes doing and doing becomes thinking” (b, p. 6).

When thinking becomes doing and doing becomes thinking, I suggest we should not think of that as an inversion, but rather as a shift. *Thinking becomes doing* suggests that thinking becomes an active process, in the context of what Speaks writes, perhaps a process that involves the hands (or other body parts) in making something. When *doing becomes thinking*, we can understand that active process as constitutive of thinking. The active process of doing becomes the primary process through which we think.

The primacy of action is also key to Alva Noë’s argumentation for his *enactive* viewpoint. Enactivism, according to Noë, puts action at the centre of processes of perception and thinking. Perception

is possible, he says, because we can act, because we have learnt to move in order to interact with the world (Noë, 2004). In order to explain the enactive view, Noë suggests that we should think of perception as touch. In order to know what an object feels like, we move closer to it, and reach out to touch it. To find out whether the object is block-like or smooth, we have to move our hand so that we can feel it at different places. And to know if the surface is smooth or rough, we need to slide across the surface to feel the texture. This is an active way of sensing, a type of exploration that Noë describes as *probing*.

Probing seems an appropriate description also for the explorative prototyping process, where a certain initial action leads to an insight that leads to further action and so forth. There is scope to analyse the prototyping process as a collection of enactive processes close to the engagement with the physical components that form the prototype.

## Exteriorised Thinking

Alva Noë gives us a clue as to how to address the physical construct in a more recent publication that addresses the use of technologies and the profound influence they exert on us. He writes: “Technologies organize our lives in ways that make it impossible to conceive of our lives in their absence; they make us what we are” (Noë, 2015). He goes on to analyse the technology of writing, of representing language in symbols. Noë suggests that writing is not just a form of communication, but that it organises thought: “Writing [...] is a technique for thinking about whatever domain it is we are writing about” and that “notations make it possible to frame problems and think about phenomena in a way that we couldn’t do without notation” (Noë, 2015, p. 40). Writing in this sense is thus a technique that is external to us, and at the same time elemental to how we think.

A similar argument is made by Youn-Kyung Lim, Erik Stolterman and Josh Tenenbergen in a paper about prototyping in the context of human-computer interaction (HCI) (Lim, Stolterman, & Tenenbergen, 2008). Their discussion leads them to characterise prototypes as both *filters* and *manifestations* of design ideas. As filters, prototypes allow designers to test the design without engaging necessarily with the full context and complexity of all the detail. A prototype can be brought back to just the essential parameters to make particular design decisions, leaving out what seems irrelevant. As manifestations, prototypes are externalisations of design ideas. Lim et al. refer to the thesis of the extended mind, a view of cognition that gives prominence to external context as constitutive of our cognitive functions. Andy Clark and David Chalmers, as original proponents of this view, explain that

**the human organism is linked with an external entity in a two-way interaction, creating a coupled system that can be seen as a cognitive system in its own right. All the components in the system play an active causal role, and they jointly govern**

**behaviour in the same sort of way that cognition usually does. If we remove the external component the system's behavioural competence will drop, just as it would if we removed part of its brain. Our thesis is that this sort of coupled process counts equally well as a cognitive process, whether or not it is wholly in the head. (Clark & Chalmers, 1998, pp. 8-9)**

The account of prototyping presented by Lim et al. could be transferred to prototyping in an architectural context, because the arguments brought forward are not exclusive for the HCI context. Just like writing, when we engage in prototyping, we establish a coupled system. We engage in a process that includes elements external to us, but that nevertheless form part of our cognitive processes.

The writings of French philosopher Bernard Stiegler, as set out in chapter 2, provide a contemporary philosophical perspective on this external coupling, especially if this involves technology such as writing, and as I propose, prototyping. The process of prototyping, especially as was the case in this research, can be described in Stiegler's terms as an *associated hypomnesis*, where a physical construct is realised and interpreted, coded and decoded, through the know-how of the researcher. Therefore, being literate at prototyping is like reading and writing: a method to structure thinking in a particular way. Section 3.3 will take the consequence of this view by analysing the process accordingly.

## 3.1.2 Design Drivers

As a process of design, the prototyping process responds to the speculative question: What if a building was made of movement? One of the underlying motivations for addressing this question was a recurring disappointment during years working in engineering practice, about a seemingly missed potential in the limited scope given to movement in terms of defining architectural space. The limitations became apparent in (1) the influence of movement on the total design, (2) the spread of movement through the building, and (3) the spatial relevance of movement. The ambition of the prototype was to take away the limitations and approach the design with movement as its primary concern.

The primacy of movement also implied a secondary role for other aspects. In the initial explorative phase, a purpose of the movement had been sought; a problem that could be solved with it. With time, however, it became clear that the problem was movement itself and that the prototype should facilitate a deeper understanding of such movement in itself. The prototype development would therefore be characterised as a quest for movement independent of its functionality. We can look at this as a form of abstraction, or as proposed by Lim et al. (2008), as a *filter* that removes those aspects that are not the core of the investigation.

The three limitations and possible responses are discussed below. This is followed by a discussion of other design drivers that

played a role in the prototype design and that concerned aspects of movement, the prototype in its physical form, and the process of prototyping. Not all of the drivers were clear at the outset of the design process. Although some of them were, most drivers gained in clarity or even only emerged during the process. The drivers, or objectives, therefore should not be read as premeditated constraints, but as a series of reference points that have guided the design.

## Movement as the Primary Design Concern

Taking away the limitations in scope of movement, would imply addressing (1) the influence of movement on the total design, (2) the spread of movement through the building, and (3) the spatial relevance of movement.

(1) Instead of movement as a secondary or supportive aspect of the design, could movement be a starting point for architectural design, and be made the central concern of the design process? A possible answer can be found in the work of Santiago Calatrava, for example in his *Kuwait Pavilion* (1992), see figure 3.1. This pavilion, for the Expo '92 in Seville, features 17 movable ribs that overhang a small piazza. Supported on two sides of the piazza, like fingers of folded hands, the ribs rotate towards the sky to form dramatic configurations, casting changing shadows on the marble floor below.



3.1 Santiago Calatrava, Kuwait Pavilion for Expo '92 in Seville.

This architectural work is all about movement. Even though it might provide some secondary spaces, the main feature of the building, highly visible and raised on a pedestal, is the array of 17 movable elements. The fixed structure in this case is supporting and secondary to the movement. Other kinetic works in the architect's portfolio attest to this importance of movement, "Calatrava's projects serve, use and explore the transformational power of movement", writes Alexander Tzonis (1999, p. 110).

The approach may be akin to that of kinetic art, where the exploration of movement as a single topic can monopolise the entire work. As a consequence, the work of architecture may fall short on other aspects, but this could be a deliberate choice.

(2) In many examples of kinetic architecture, movement is confined to a single component or an aspect of the space, such as a roof, a wall, or a section of a facade. Often, this renders movement a feature placed amongst others. But rather than movement as an add-on, or movement that could be pointed at precisely, could movement involve the whole building? Could movement surround the occupant?

A suggestion for an answer can be found in the Hyperbody's *Muscle NSA* (2003), which was made for the *Architectures Non Standard* exhibition in Paris (figure 3.2). *Muscle NSA* is an inflated ellipsoid that is contained in a net of pneumatic muscles. The muscles contract when their internal air pressure is raised, allowing the net

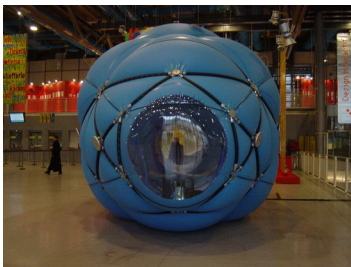

3.2 Hyperbody, Muscle NSA.

to knead the main volume. The actuator net surrounds the whole volume, and as a consequence, every part of it can be made to move. Although the space could not be entered by visitors, a circular window on either end allowed people to look inside and experience the spatial transformations.

The practical concerns of most buildings designed for occupation rule out wobbly floors or thin walls laced with contracting and expanding actuators. But these elements do support an enclosed environment that is moving everywhere. Even the contraction of a single actuator will affect the entire shape because of the indeterminacy of the structure. This makes it futile to isolate movement in a part of the larger structure.



**3.3** Henrique Mindlin, Residence of George Hime in Petrópolis. Calder's mobile is seen hanging in the double-height space between the stairs.

(3) Rather than defining space with the solid elements that confine it, could movement instead provide a sense of space? An indication for this might be found in the residence for George Hime, near Petrópolis, in the mountains of Rio de Janeiro state in Brazil.

The friendship between Alexander Calder and the Brazilian architect Henrique Mindlin led to a space in the house that was dedicated specifically to a large mobile made by Calder for the house (Calder & Saraiva, 2006), as seen in figure 3.3. Similar to the large mobile in São Paulo, discussed in section 4.2, a connection between floors is established, but in this case the space and the mobile were designed for each other.

A mobile is, as Jean-Paul Sartre wrote, “a little local festival; an object which exists only in, and which is defined by motion; a flower which dies as soon as motion stops; a spectacle of pure movement just as there are spectacles of pure light” (1947). The mobile affects the space not as an object, but as movement. A particular spatiality is created by the invisible traces of the petals—past, present and future captured in simultaneous gestures of varying tempo and directionality.

The mobile does not bound space, or define space by confining it, but it creates space from within. This reaching, or probing, holds the potential to characterise a space by moving in a particular way.

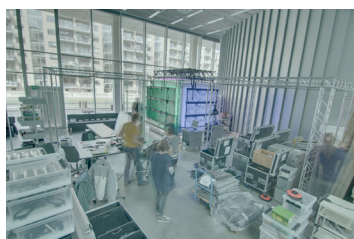

**3.4** Intermedia Lab at ITU.

## Interior

With an eye on the practicalities of making a prototype space, it was clear from the start that this would belong in the realm of another building's interior. This meant that the prototype did not have to endure the Danish climate, and could be constructed without weather proofing inside a controlled environment. However, the dimensions of the piece should at least be such that a person could be inside it in order to position the work as an occupiable space.

IntermediaLab (figure 3.4), the largest lab at IT University, would be the host space. The prototype was positioned next to the windows to get a visual connection with the external conditions.

IntermediaLab would facilitate a relatively lengthy design and construction process with sufficient layout space, and it would, by means of available tools and equipment, allow for the assembly of the prototype by a single person. Though not a requirement per se, single-person assembly seemed like a valuable approach in allowing the researcher to be both designer and maker from as close a perspective as possible.

## Open for Change

An objective that gained clarity over time was for the prototype to remain open for change and to regard the prototyping process as similar to the *breadboarding* process in electronics. A physical breadboard is like a digital canvas with strips of connected holes that act as sockets to connect electronic components. No soldering is required, and variations of physical circuitry can be quickly assessed. During the assembly of one of the early models, preceding the prototype, I discovered that I was seeking to construct everything for potential modification or for the reuse of parts in later models. In part, this was driven by thriftiness towards the available budget. But also, having performed a great deal of design work in the digital domain, the concept of an *explicit history* (Rutten, 2007) has become second nature. The ability to not just retrace one's actions, but to step back into the process and make alterations that have knock-on effects on later actions is inherent in digital parametric models. To me, it also seems an ideal quality of a physical prototype that can be adjusted and tweaked until it works. This is why I would use screws instead of nails and bolts instead of adhesives. And this is why I would keep the structure open, so that its parts remained accessible. The control system wiring is even literally breadboarded and could be modified or extended by simply plugging in additional components.

## Implicit Guidelines

A number of implicit guidelines have also been adhered to. *Implicit*, because they form part of the baggage of years of design experience. These guides include that kinetic systems in buildings should exhibit a certain mechanical clarity in order for them to be well understood. This is important ultimately for the safety of the occupants because the various states of the mechanism, as they are well understood, can be properly analysed. Another guideline that is related is that kinetic structures should be designed for maintenance. The underlying thought is that the safety of a mechanism is determined in part by its maintenance, and that maintenance is more likely to be conducted if the parts for maintenance can be easily accessed. A third implicit guideline is the search for novelty. Although tried-and-tested solutions have an advantage in terms of engineering development, design is often about finding new solutions. Such new solutions may be achieved in part with existing technologies—novelty should therefore be understood as an incremental measure.

## 3.2 Process Description

This section is structured as a series of influences that have characterised consecutive phases in the process of design and making. Each of these influences has led to a key development of the prototype. The descriptions gradually cover more detail, up to the level of joining bolts and nuts in the assembly stage of the prototype.

The purpose of bringing the reader to this level of detail is first, as a way of documentation of the process. Second, it is to demonstrate the range of thinking that is part of prototyping, covering ideas and references, as well as the practical concerns such as material choice and order of assembly. Third, the description includes not just the shortest path to the final prototype, but also some of the dead ends and failures along the way. In this way, the reader is brought as close to the process as possible. And fourth, the description provides the material for analysis in section 3.3, which relates similarly to multiple aspects of thinking through the prototype.

The various influences, although roughly covered chronologically, have seen significant overlaps and jumps back and forth. The subsections are numbered for ease of reference only, as they are meant to express a structure that is rather fluid, similar to the process it describes. Together with the illustrations in this section, the subsections paint a composite picture of the process as a whole.

The first influence discussed in subsection 3.2.1 is the use of vertically orientated strips to define space. In subsection 3.2.2, the aspect of emergence is treated in relation to the generation of movement. An influential scale model that was made with vertical strips is described. That model aims to employ the logic of computational generative algorithms in a physical construction without electronic computation. Developing the idea of generative motion further, in subsection 3.2.3 the mobile is investigated as a model for movement in a building.

A significant development for the expression of movement is discussed in subsection 3.2.4. The vertical strip is bent into an arch and twisted at the base. This causes the arch to bend sideways. Various scale models confirm this behaviour and demonstrate the movements of an array of strips. The combination of purposeful motorised twisting at the base of the arch and generative movements of the strip due to airflow is reviewed in subsection 3.2.5. Subsection 3.2.6 then examines the process that led to the decision to make the strips out of transparent material.

Lastly, subsection 3.2.7 covers various stages of the assembly process, starting with the static base structure and ending with the control interface for the directed, motor-driven movement.



3.5 Augmented Oculus Rift.

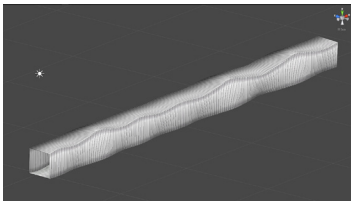
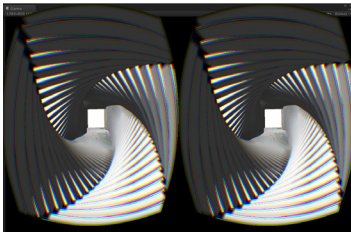

3.6 Virtual dynamic tunnel. Rendered for VR headset and isometric view.



3.7 Cantini Crescenti, Túnel.

## 3.2.1 Vertical Slats

Probably every design project I have worked on has started with drawings to visually test ideas. Over the course of my years in engineering practice, 3D modelling had taken an ever-prominent role and I would often be sketching in 3D. Although the intention of these sketches and models would be primarily to document the design for physical construction, the 3D modelling environment had increasingly become a space in itself. Therefore, initial work on a kinetic prototype took the form of an exploration in 3D virtual space. The use of a new generation of virtual reality headsets that started with the Oculus Rift added some novelty value, but it seemed to me that this was an interesting experimental dimension mainly for non-experts who have little experience with navigating 3D space. The use of augmented reality, where virtual and physical environments become integrated, has the potential to test design ideas in an existing physical context, and although an effort was made to work with this concept (see figure 3.5), the technology lacked the precision and outlook for improvement to convince me to use it further.

An initial virtual environment was created as part of a course project that allowed a user to visually experience a kinetic environment using an Oculus Rift headset. The environment was shaped as a tunnel that consisted of a series of frames (figure 3.6). The frames could increase in dimension and rotate as one walked through the tunnel, thereby changing the interior space. There is an uncanny parallel with the art installation *Túnel* (2010), of which I was unaware at the time and that was realised as a physical reality by Brazilian artists Cantoni Crescenti (figure 3.7). *Túnel* would also deform when it was trodden, and the relative rotations of the frames would produce a similar aesthetic as my virtual environment.

What remained after this investigation was a dedication to the movement of vertical narrow elements, slats or strips, that would move relative to each other. A key reference here was Calatrava's gracefully opening depot in Coesfeld, with three doors that are each made of 73 vertical, folding slats. Because the positions of the hinging points are shifted, following an arc, the doors turn into curved awnings as they open. This concept with slats and hinges, folding in and out of a plane seemed to hold promise for applications that were visually interesting and provide functionality at the same time. A particular application would be a robotic wall that could transform into a bench, or a table with seats, or shelves, which was contemplated for use in elderly care where temporal affordances could serve as a reminder of daily activities.

In contrast to soft moving surfaces made of fabrics, such as Barkow Leibinger's *Kinetic Wall* (2014) and many academic projects (*The Living, Breathing Wall* (2013) by Behnaz Farahi, *ExoBuilding* (2010) by the Mixed Reality Laboratory at the University of Nottingham, *Reciprocal Space* (2005) by Ruairi Glynn), a hard surface would provide a certain robustness for use in a building context, would have some advantages for maintenance and cleaning, and would not be limited to an indoor environment. On the other hand, it would require careful design to avoid exposure to the mechanical



system and finger traps. But I felt that some of these aspects were venturing too soon towards functional problem solving, rather than exploring the design space of movement.

### 3.2.2 Emergence

Calatrava's doors in Coesfeld only move in one particular way, repeating every cycle with the same choreography that is carefully specified in the design. Within the time domain, this could be regarded as a new form of stasis: at every same time step in the cycle, one would find the same form. "Once the cycle of motion repeats itself a more emphatic stasis sets in", George Rickey writes about a category of kinetic art that he refers to as *machines* (Rickey, 1963, pp. 222-223). But, what if something like the door of folding slats could be designed with a mechanism that provides a level of uncertainty—making it move differently with time, every time. In computer code, such variation can be achieved by using one of many generative algorithms. Software that employs *L-system* grammars (Togelius, Shaker, & Nelson, 2016) or *Perlin noise* (Perlin, 1985), for example, is used in computer graphics to render varied, natural-looking scenes that are consistent in their variety. This software could easily be used to control an actuator, but could such a process be coded in a physical mechanism?

One mechanism that creates unpredictable, chaotic movement is a coupled pendulum system. A double pendulum system, for example, where one pendulum is connected to the end of another pendulum, or variations on this where multiple pendulums are connected to one another, will exhibit behaviour that is seemingly random. Henri Poincaré, the French mathematician who laid the basis for modern chaos theory, explains that such behaviour is not random but determined. However, even the slightest variation in the starting condition results in an entirely different outcome:

**[I]t may happen that small differences in the initial conditions produce very great ones in the final phenomena. A small error in the former will produce an enormous error in the latter. Prediction becomes impossible, and we have the fortuitous phenomenon. (Poincaré & Halsted, 1913, pp. 397-398)**

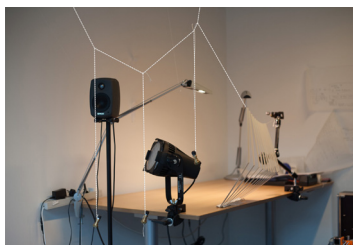

3.8 Pendulum Constellation.

I decided to construct a small-scale model with paperboard and wire to understand how this could work. The model combined an architectural element with a device creating chaotic movement: a series of folded strips, representing a wall-like element, connected to a coupled pendulum system (figures 3.8 and 3.9). The pendulum constellation was made of wires and weights. Three pendulums were suspended from a catenary wire, effectively creating a 1:3 pendulum system, a primary pendulum with three secondary pendulums attached. The folded strips were all suspended from the same continuous wire that was connected to the pendulums at one end. Once the pendulums were (manually) excited, a movement pattern would emerge. Through the coupling with the wire holding the strips, the strips would exhibit a movement as a result. A vertical movement of the wire resulted in more or less folding of the

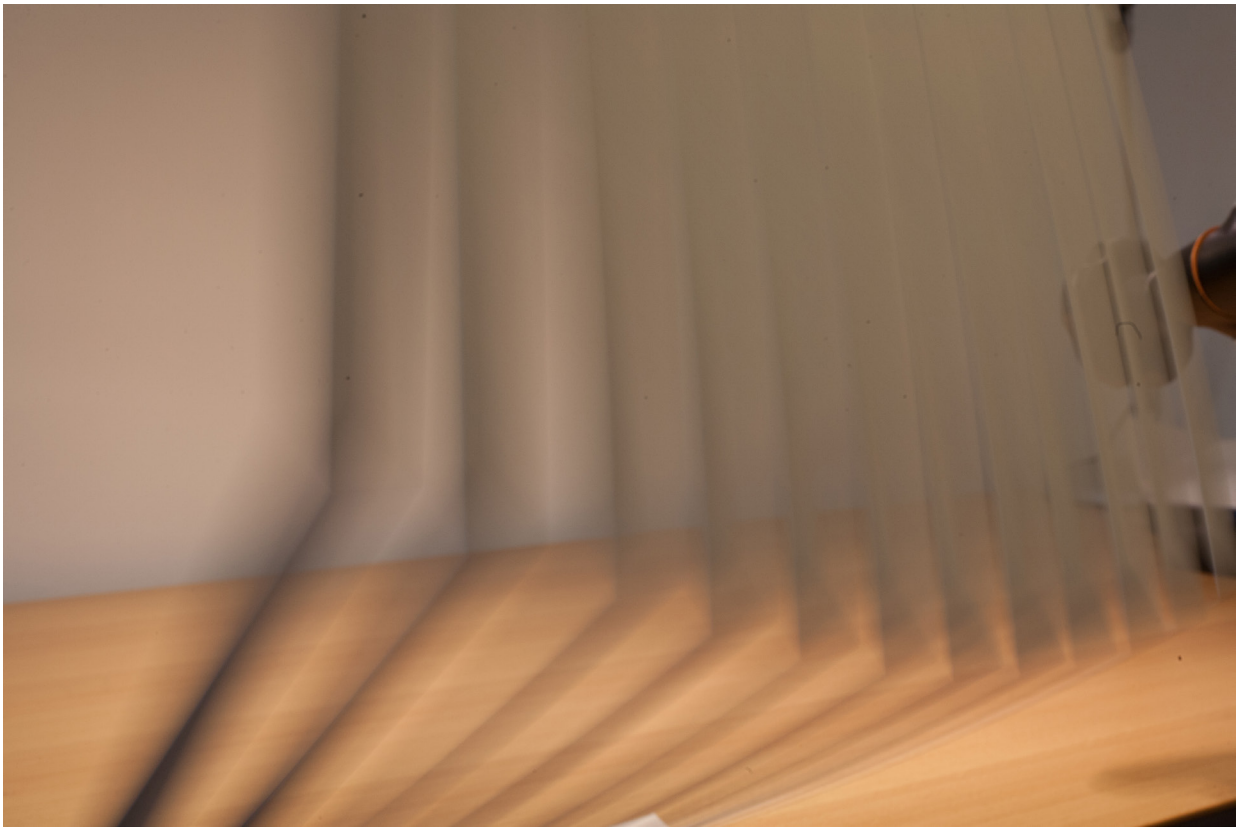

### 3.9 Pendulum Constellation.

strips and horizontal movement would tilt the strips in the same direction.

Although the model was coarse, it provided a number of insights and raised even more questions. First, I was surprised by the resulting movements of the strips. Observed from nearby, without taking account of the pendulums, there was some truly unpredictable movement. Having grown up by the seaside, I have spent considerable time looking at waves rolling on the beach, always with a mix of anticipation and surprise. This was similar. Movements could be sudden, but they would occur in a context of other movements of comparable magnitude. Second, the observed movements would be those coming from a single point of the pendulum system. The complete movement of the constellation was much richer than just that of a single point. There were the swings of the three secondary pendulums, sometimes colliding or becoming intertwined, the sway of the primary pendulum, distorted by forces working against each other and then in unison. And why would one point along the line of the primary pendulum be a better connection point for the strips than any other? Third, by connecting the strips directly to the pendulums, the strips became part of that same system, influencing its behaviour. Rather than considering this to be two connected systems, it might just as well be regarded as one constellation inclusive of pendulums and strips. And in that case, was there a need for separate pendulums, or could the strips, based on their own properties, become the primary agitators of the system? And fourth, how would energy be provided to the system if not through a motor? In the model, I would simply lift one of the pendulums and let go, but if this was so arbitrary, could I not rely on another source of energy?

The artworks of Tim Knowles consist of traces of the unseen. For example, one series documents the route of a package that is sent by mail. A drawing is made inside the box, of the box's handling by a puck that slides between two plates, drawings lines with every movement of the puck. In another series, Knowles has trees fitted with pens or markers to record the movements of branches as they are animated by the wind, for example in *Oak on Easel #1* (2005) or *Spruce on Easel #2* (2006). As generative art, these works emerge in the coupling of the particular physical properties of the tree, and the gusty patterns of force exerted by movements of air. There is no external system here that controls the motion. The branches are directly activated by the wind. The properties of the tree are a given, as they have grown to be that way. George Rickey's wind sculptures, such as *Breaking Column* (1988), are similar in being moved in a coupling with the environment—and they are different in that they are given their specific properties by the artist.



3.10 Design for access road to IJmuiden aan Zee.

In 2011, I worked with a Dutch architecture practice, bureau SLA, on a project to enhance the visual attractiveness and recognisability of a main road leading to the beach in IJmuiden, one of Amsterdam's go-to beaches (figure 3.10). Arup was responsible for the part of the proposal that involved the mechanism of a row of moving poles that would sway in the wind like giant reeds. Although, unfortunately it was never realised, in that proposal, the poles themselves were pendulums that would be directly activated by wind. As in Rickey's sculptures, the poles were designed with specific properties. A staggered series of springs would ensure interesting motion for low as well as high wind speeds. The poles were not interconnected, but it was thought that a connection would appear visually once the row was jointly activated. This assumption was based first on the wind itself having certain dimensions, and gusts hitting not just one, but multiple elements at the same time, and second on the tendency of humans to perceive patterns, even if they might not be there, broadly referred to as *apophenia*.

Such emerging patterns are also central to the work of Swiss sound and installation artist Zimoun. His installations are often created as a large number of relatively simple machines, all copies, acting in the same way. I have experienced two of the larger, more immersive works and did indeed witness such patterns, either as ripples and waves in *435 prepared dc-motors, 2030 cardboard boxes 35 × 35 × 35cm* (2017) or as a cumulative rotating movement in *329 prepared dc-motors, cotton balls, toluene tank* (2013). An incentive to produce something similar was provided by a conversation with professor Mike Xie at RMIT in Melbourne, leading to a brief investigation of soft actuators. A publication by a multi-disciplinary team from Harvard showed how a rotary actuator could be made of silicone forms (Dian et al., 2015). The internal structure would buckle when internal pressure was lowered, referred to as *snap-through instability*, causing a rotary movement. The actuators described were produced in the typical multi-stage process that involves making a mould first, but Mike Xie suggested we could take advantage of the advancements of 3D printing technology. Flexible materials could now be printed directly, which could potentially shorten the process of making soft machines. Initial tests that were printed at RMIT's advanced manufacturing precinct looked

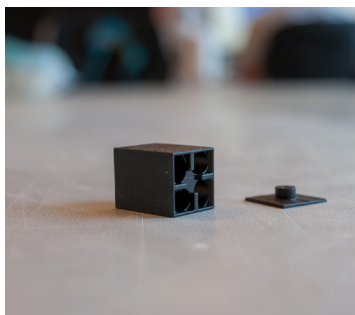

3.11 3D-printed soft actuator.

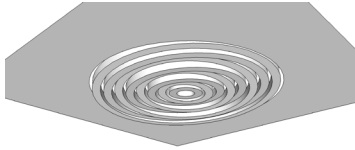

3.12 Sketch for mobile of concentric circles in ceiling.



3.13 Mobile of planks, forming a wall. Detail of spring-loaded hinge.

promising (figure 3.11), but the costs of repeating the process on a large scale in Denmark were prohibitive.

### 3.2.3 Mobile Architecture

The endless variations of movement in certain dynamic systems have been also explored in the mobiles of Aleksandr Rodchenko, Man Ray, Bruno Munari and perhaps most famously Alexander Calder. By suspending objects in a carefully orchestrated equilibrium, they are moved by small drafts into ever-changing configurations. To emphasise the importance of the actual movement, a recent show of works by Calder in the Whitney Museum of American Art in New York even had *activators* at work, art handlers trained to nudge the sculptures into motion (McDermon, 2017).

Even though Calder's work, in certain contexts, can be said to transform space, as outlined in subsection 3.1.2 and section 4.2, his mobile pieces have not been constitutive of architecture, in the sense that they form for example walls or ceilings (static ceiling panels by Calder however are installed in Carlos Raúl Villanueva's University of Caracas auditorium (1953) in Venezuela). The flow of force in many of Calder's mobiles follows a curve, sometimes branching into a network of tributaries, but is fundamentally one-dimensional. Architectural elements, such as walls, floors and ceilings act at least two-dimensionally. However, it is not inconceivable that mobiles are constructed two-dimensionally as well, and therefore that there could be walls or ceilings constructed as mobiles. As part of my investigation, I made a 3D kinetic sketch for Oculus Rift of a mobile ceiling, constructed as concentric rings that were balanced on each other, suggesting an undulating surface (figure 3.12). I have also developed some sketches and physical tests for a mobile with horizontal slats hung off each other to form a wall. To make the mobile act as a wall, its internal connections were sprung so that its state of equilibrium would be in a vertical plane (figure 3.13). This second path of forces, the in-plane torsion moments in the springs, could be considered the second dimension of the mobile.

### 3.2.4 Bending and Twisting

In a discussion about my research work, Nick Williams, then a researcher at RMIT university, asked the question why movement only seemed to occur through discrete moving elements. Could movement not take place in the material? And was it necessary to have driven actuators, or could activation also come from within the material. He was perhaps thinking of projects such as *HygroScope* (2012) and *HygroSkin* (2013) by Achim Menges and his research group at ICD in Stuttgart, or *Bloom* (2011) by Doris Sung in Los Angeles, where material is activated by variations in humidity and temperature, respectively. Although I did not immediately act

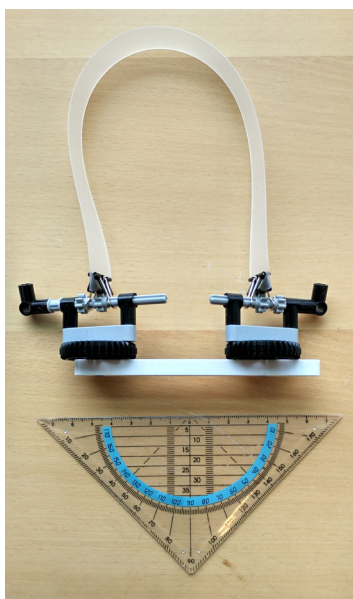

3.14 Plastic strip and Lego.

on that idea, it remained in the back of my mind as a direction to explore. In my work practice at Arup, I had never quite taken seriously the potential of such material activation, mainly because I had been working at a different scale and with other constraints regarding the longevity of the technology. The dimensions of an interior installation and the temporal character of a research prototype would be better suited for such exploration.

On reading a paper by Jan Knippers and Thomas Speck (Knippers & Speck, 2012) that was related to the engineering work on the *One Ocean Pavilion* (2012) in Yeosu, Korea, I encountered a description of an organic mechanism in the *Strelizia reginae*, bird of paradise flower. The ingenuity of that mechanism is that when a bird sits on the extended perch to drink the available nectar, the flower uncovers the anthers containing the pollen. Intrigued by this mechanism, I worked to replicate this at my desk with a sheet of thin paperboard, and this had me tinkering with a strip beyond the mechanism that was patented by Knippers (figure 3.14). Bending the strip into an arch, and exploring its degrees of freedom, I noticed that upon rotating the base, the strip would twist sideways. This seemed an interesting effect.

When considering ways to manipulate a strip, curving the long direction cylindrically is the path of least resistance. If a strip is bent into an arch, it may sustain significant loading, as long as it is applied uniformly and in the direction of its supports. However, when the loading is uneven, the arch may buckle, which is considered undesirable behaviour in most engineering applications. Nevertheless, this mode of movement has been explored, for example, in *Bending\Arches* (2014) by Morten Winther at ITU in Copenhagen (Winther, 2015) and in architectural context in *Spirit | Ghost* (2014), by a team at the TUC School of Architectural Engineering in Crete (Oungrinis & Liapi, 2014). In these projects, the arches are pulled or pushed downwards respectively, destabilising the natural form of the arch and relying on its elastic behaviour to bounce back once the force is released.

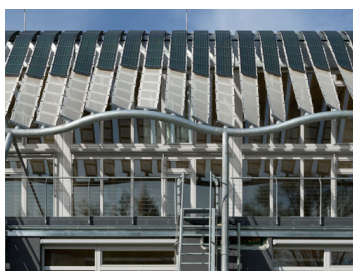

3.15 Flexible strips in Soft House, Hamburg.

The buckling of strips at *One Ocean Pavilion* is of a different nature. By pushing two corners of the vertical strips, one side of the strip buckles forward, the direction induced by a pre-camber that curves the facade slightly in its rest state. The buckling causes a strip to slightly tilt and create a gap with the adjacent strip. The result is an opening that allows light to enter the glass facade behind it.

Twisting strips have been applied in various building facades, for example in ACME's *Victoria Gate Car Park* (2016) in Leeds, or John McAslan + Partners' *British Embassy Algiers* (2009), but these examples are static. The experimental *Soft House* (2013) by Kennedy & Violich at the IBA in Hamburg (figure 3.15) integrates flexible strips and photovoltaic cells. On top of the roof, the strips are made of GRP that form arches and can be bent to optimise the electricity production at each time of year. Overhanging the roof, the strips continue as *twisters*, that are made of a textile membrane. Motors at the bottom of the strips induce the twisting motion used to shade the building and optimise the direction of the photovoltaics (IBA Hamburg GmbH, 2013). As Daniel Rozin has shown in his art piece *Twisted Strips* (2012), mesmerising patterns can be created through

the control of dynamic twisting, especially when this is repeated across a number of adjacent strips.

## Twisting Arch

With the twisting arch in my hands, I realised that this met a lot of my criteria. First, it was a simple mechanism that only required the actuation of a single degree of freedom: a rotation in the horizontal plane. The simplicity of the mechanism means that its workings can be well understood, which is particularly relevant if applied in a building context that should be safe for human occupancy.

Second, the arch was neither a wall, nor a ceiling, but acting as both at the same time in enclosing a space by its form. Movement of the arch would therefore not be confined to a specific area or a pointable moving part, but would be present more generally in the space defining elements.

Third, in terms of installation and maintenance, there was an advantage in having the mechanical parts where they can be easily accessed, while the movement would be distributed throughout. Whether the arches would start at floor level or a metre above, it would mean the actuators would be at safe working height.

Fourth, in my years in practice as an engineer of movable architecture and in my more recent study of kinetic art and architecture, I had not encountered the phenomenon as witnessed in the bent strip. Although this is far from a guarantee that the principle has not been applied elsewhere, it does indicate its occurrence would be relatively rare. Developing this concept further would therefore be a worthwhile investigation and perhaps constitute a contribution to the field.

And fifth, it was also, finally, a response to Nick Williams. This mechanism did not rely on activation through relative changes in layers of a composite material (bimetal in Sung's *Bloom* and a custom veneer in ICD's *HygroSkin*) and would require external activation from a motor. Its interesting behaviour was a function of the material configuration, not in a traditional mechanistic paradigm with discrete moving elements, but through a continuous elastic element responding to a forced displacement of its constraints. The sideways sway of the arch was not directly but indirectly activated *through* the material.



3.16 Single strip in Foamalux.

## Spacing the Twist

Then came the questions. Was this phenomenon of twisting and bending only occurring because I controlled the movement with my hands? How could I rule out quickly that any subtle movement of my fingers was actually causing the sideways bending? And even

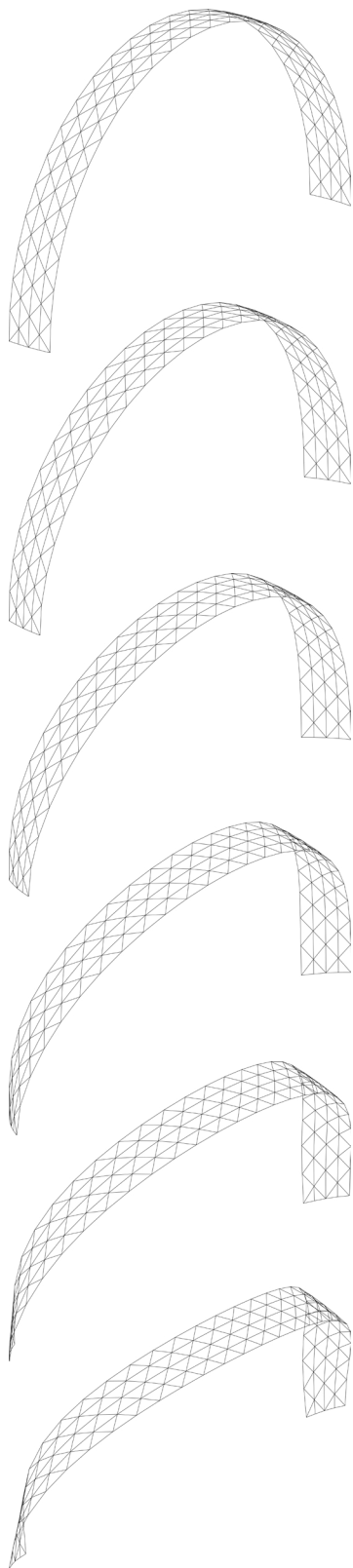

3.17 Simulated sequence of strip movements.

if it would work for a small paper strip, could this behaviour be replicated on a larger scale?

A number of small tests were performed in order to address these questions. To ensure that it was only the rotation in a horizontal plane that made the phenomenon so compellingly simple, I assembled some Lego to quickly assess this (figure 3.14). After the test had provided sufficient reassurance, I used a 2 m-long strip of 3 mm-thick PVC foam board, and again observed the same phenomenon, although experiencing, understandably, considerably more resistance (figure 3.16). This would prove to be the challenge with scaling up the system. With increasing dimensions, the material had to be thicker to prevent the arch from buckling when in a resting state, but the thickness would also make it harder to twist the arch in order to actively deform it, thereby increasing the local stresses in the material.

At this time, I was also sketching options for the geometry in 3D. I used SketchUp, a 3D modelling programme, to visually test the proportions of the arches (width, taper, span), vertical position of the arches, the number of movable arches and the packaging and assembly of the mechanism. In order to draw the deformed strips at various rotation angles of the footings, I used an approximation of the strip behaviour in another 3D modelling environment, namely Grasshopper for Rhino, together with Kangaroo, a plugin for live physics simulation. The strip was modelled as a flat mesh of springs with a number of constraints to model physical properties such as material stiffness and the section's thickness. Parametrically, the footings could be rotated and the strip would take its presumed position (figure 3.17).

It was considered at this stage to configure the strips such that an overlapping arrangement could be established, either in rest or deformed states. This would have signalled a practical-use case of a roof providing shelter. In order to do this geometrically, however, some nesting arrangement would have to be established with variations in the arch dimensions. The complication lies in the deformation of the strip. If we look at one edge of the strip, as the arch twists at the bottom, locally the edge moves outwards, potentially creating space to nest another strip. Higher up however, the same edge moves down and inwards, blocking the nesting of another strip. In order to keep the clarity of the concept intact, I decided to space the strips 50 mm apart,  $1/5$ th the width of a strip, enabling movement without collision until a  $60^\circ$  angle of the base was achieved. This angle was larger than expected to be practical in the prototype, but the large gaps would emphasise that the work did not, in fact, seek to solve the shelter problem, but would rather leave ambiguity in this regard.

## 3.2.5 Two Types of Movement

Working with the 2 m strip, it also became apparent that two types of movement could be integrated in the work. On the one hand, a concept had now been developed to actively control the twisting

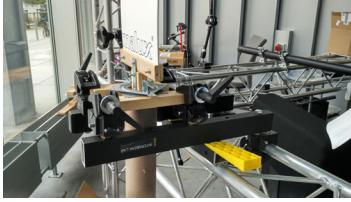

**3.18** Strip end with tube protruding through rotary bearing.

and bending of a strip into a desired form, by rotating the bases. On the other hand, a generative type of movement would exist where the strip would be swaying in the plane of the arch, bending around the flexible direction of the strip. This movement was initially assumed to be activated from below the installation. One or two sides of the strip would be extended with cylindrical tubes connected through the centre of the rotating support (figure 3.18). Under the support, the tubes would be exposed to a continuous airflow in a direction perpendicular to the arches. A lateral movement of the strip extension would translate in a swaying motion of the arch. The strip ends would be cylindrical to excite them through vortex shedding, which causes an oscillating pattern of lateral forces.

In terms of its mechanical configuration, the supports for the 2 m strip were so-called *pins*. Considered in the two dimensions of the arch, they did not allow translation, but the supports were free to rotate. At this strip length, the stiffness of the material was sufficient to keep the arch stable. With the final strip length of 4 m, however, the material thickness was such that the supports had to be fixed (and stiffened over an initial length) in order to give the arch sufficient stability to stand up. This meant that it was not practical to implement the mechanism of the extended strip, because movement of the cylinder underneath the support could not be transferred to a movement of the strip above. However, now that the arches themselves were so flexible, instead of exciting them through an additional mechanism, out of sight, at the strip ends, the arches themselves could be excited just as Tim Knowles' tree branches or bureau SLA's moving poles. Or as Amanda Levete's temporary *MPavilion* of 2015 in the Queen Victoria Gardens in Melbourne, which featured a roof made of translucent petals. Some of the petals were supported on flexible columns that would allow the wind to sway the petals, activating the roof elements directly. The second, generative type of movement would therefore also be directly related to the geometry of the strip and the material properties.

### 3.2.6 Transparency

The dimensions for the prototype were set based on the geometric studies I had undertaken in the 3D software. I wanted the space to be large enough to stand in so that it could be easily explored and experienced as a space. At the same time, I had to set a limit on the length of the strip in order for it to be manageable to install and to keep a working ratio between bending and torsion stiffness. The width of the strip was set by visual considerations, although a wider strip would increase the torsion stiffness and would therefore have an effect on the design of the drive mechanism. The result was a strip of 4 m in length that would span approximately 2.5 m and would be about 1 m raised from the floor. There would be eight strips of 260 mm in width with 50 mm gaps.

The material I was initially considering for the strips was the same white PVC foam board used for the 2 m strip. According to my





**3.19** Laminated strip. The strip could not stand up under self-weight.

calculations, it had to be 4 mm thick in order to perform as desired. However, the material was sold in maximum lengths of 3 m, therefore I had to produce the strips myself as a spliced lamination of two 2 mm-thick layers. To reduce material waste, I optimised the cuts so that a full panel of  $3050 \times 1560$  mm would produce four complete strips. The splices would be angled as sharply as possible, leading to an approximately  $60^\circ$  angle. In this way, the splice would only minimally affect the bending stiffness of the laminated strip. The gluing process was a two-stage process involving the application of a primer and then glue. The open time for the glue was maximum four minutes, which was challenging given the large surface that had to be prepared. In order for this to work, I prepared a setup that required minimal effort in aligning the pieces once the glue had been applied. Nevertheless, the alignment proved difficult to achieve and the glue would only allow a single attempt. The first complete strip that I manufactured looked badly produced, especially around the splices. After the first attempt to make the arch stand damaged it further (it buckled under self-weight), the material choice had to be reconsidered (figure 3.19).

## Glass, Polycarbonate

Through a conversation about the flexibility and strength of thin glass with Alistair Law, an associate in the specialist facade team of Arup in London, the material considerations took a different turn. Up to that point, I had considered the white foam board twofold: first on its merits of satisfying the mechanical criteria and second, on it being a nondescript generic material that did not need substantiation. Of course, the gluing fiasco demonstrated the material had a very particular character and showed that the twofold approach had been naive and required a more critical attitude. Thinking about the application of glass allowed this. The premise was that instead of using foam board, the strips would be made of glass. Thin glass, with brand names such as Gorilla® and TIREXtreme, had gone down in cost due to its application in the touchscreens of mobile devices. The glass is strong and durable, and due to its flexibility, it could be a candidate material for the flexible strips. It would also be innovative to apply glass as a dynamic material, twisting and bending and providing a poetic ambiguity of something perceived as being as fragile as glass being twisted so elastically.

Although I had been considering transparent material for the strips earlier in the process, I had dismissed it as attracting too *much* attention. Thinking of acrylic, I thought the reflections would be too hard and that there would be a certain shine about the material, that would not suit the aesthetic I was seeking. The thought of glass changed that, as it would give a much higher-quality finish to the work. Reflections would still be hard, but would be combined with good optical qualities and light transmission. So, the material would still attract attention, but it could also disappear. The material would be perceived when it was moving, as it changed the environmental conditions, but it was also symbolic of not being there at all. This would place the focus in the prototype on the movement first, but at the same time, it provided a second layer

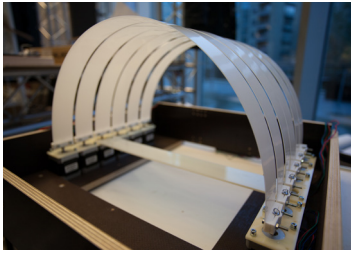

**3.20** Scale model 1:15 with opaque strips.

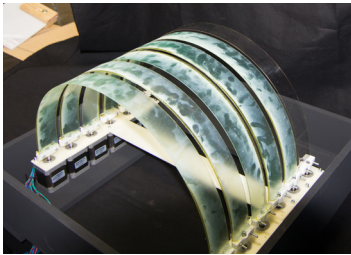

**3.21** Scale model 1:15 with transparent strips.

that concerned the material taking on different forms. On this second layer, the material would be reminiscent of the delicacy of soap bubbles and of the pioneering work that Frei Otto achieved with soap film on form-finding light-weight structures through defining the boundary conditions.

The project was given a spin-off with a small team in Arup developing the idea of a thin glass dynamic pavilion. The pavilion could showcase Arup's expertise in glass design, and pull in facade contractors and glass manufacturers for the production of the pavilion. The pavilion would be a further iteration of the research prototype with a similar layout of eight strips and with the same dimensions. Arup's internal research funding allowed for some preliminary work on the design of the strips in glass. Structural finite element analysis was performed to establish the required thickness and treatment of the glass and the forces required to twist it. Sketches were also developed for the brackets holding the glass at the base. I contributed design drawings for a more robust and precise actuation system and for a pedestal on which to showcase the glass. With the aim of showcasing the pavilion to a wider audience, a key concern was safety. This was approached in the glass itself, through lamination, and in keeping the glass out of reach. The 4 m length required for the strips poses a manufacturing challenge. Although the glass is produced as float glass in continuous production, the length is restricted by the required handling and treatment of the glass after its initial production. Both thermal and chemical tempering processes are bound by the limits of the necessary equipment, which may restrict the strip length to approximately 3.2 m.

Due to the lead times on thin glass, and the practicalities of implementing this in the research prototype, an alternative material was sought. After consulting with a lead plastics supplier in Denmark, RIAS, polycarbonate was chosen for its optical qualities and structural properties. Polycarbonate is widely used in buildings, also in the envelope, in roof lights, for example. It is safe to use as it does not break in a brittle way, but it bends without colouring. A 4 mm-thick panel was chosen and cut into 250 mm strips of 4050 mm in length. Before production of the prototype, a scale model was made at scale 1:15 with six strips that were made of 0.5 mm polycarbonate foil (figures 3.20 and 3.21). The model was used to visually investigate the strips, their movements and various movement patterns (figures 3.22–3.24).

**3.22** Scale model 1:15 with transparent strips.

**3.23** Scale model 1:15 with transparent strips.

**3.24** (page 106-107) Scale model 1:15 with transparent strips.

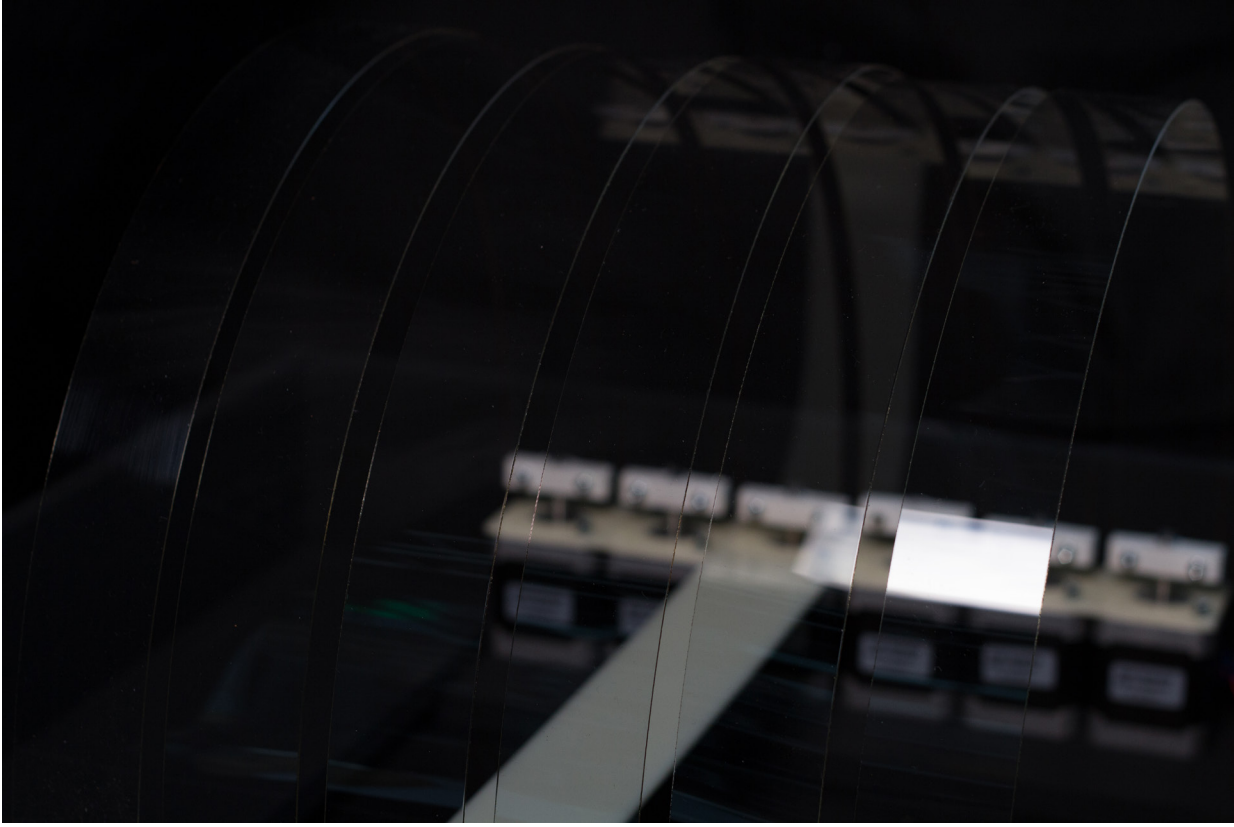
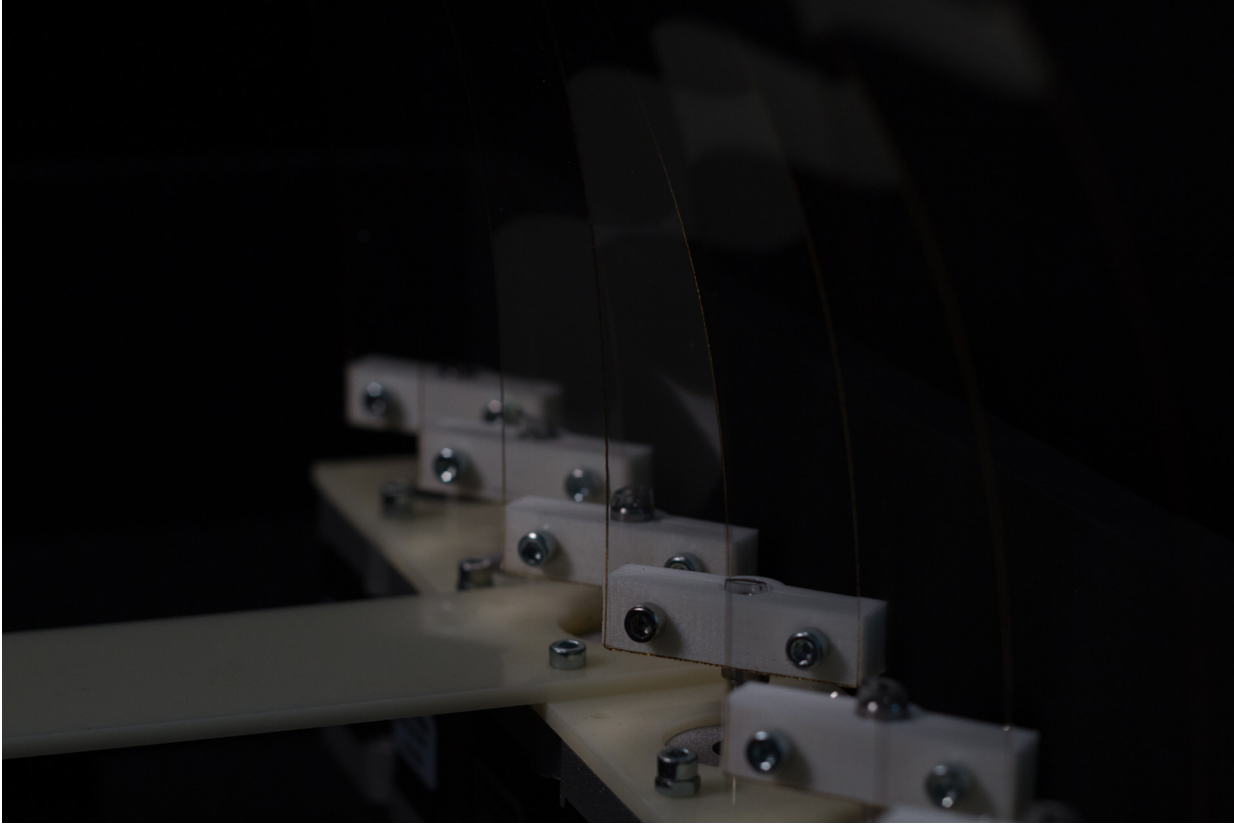

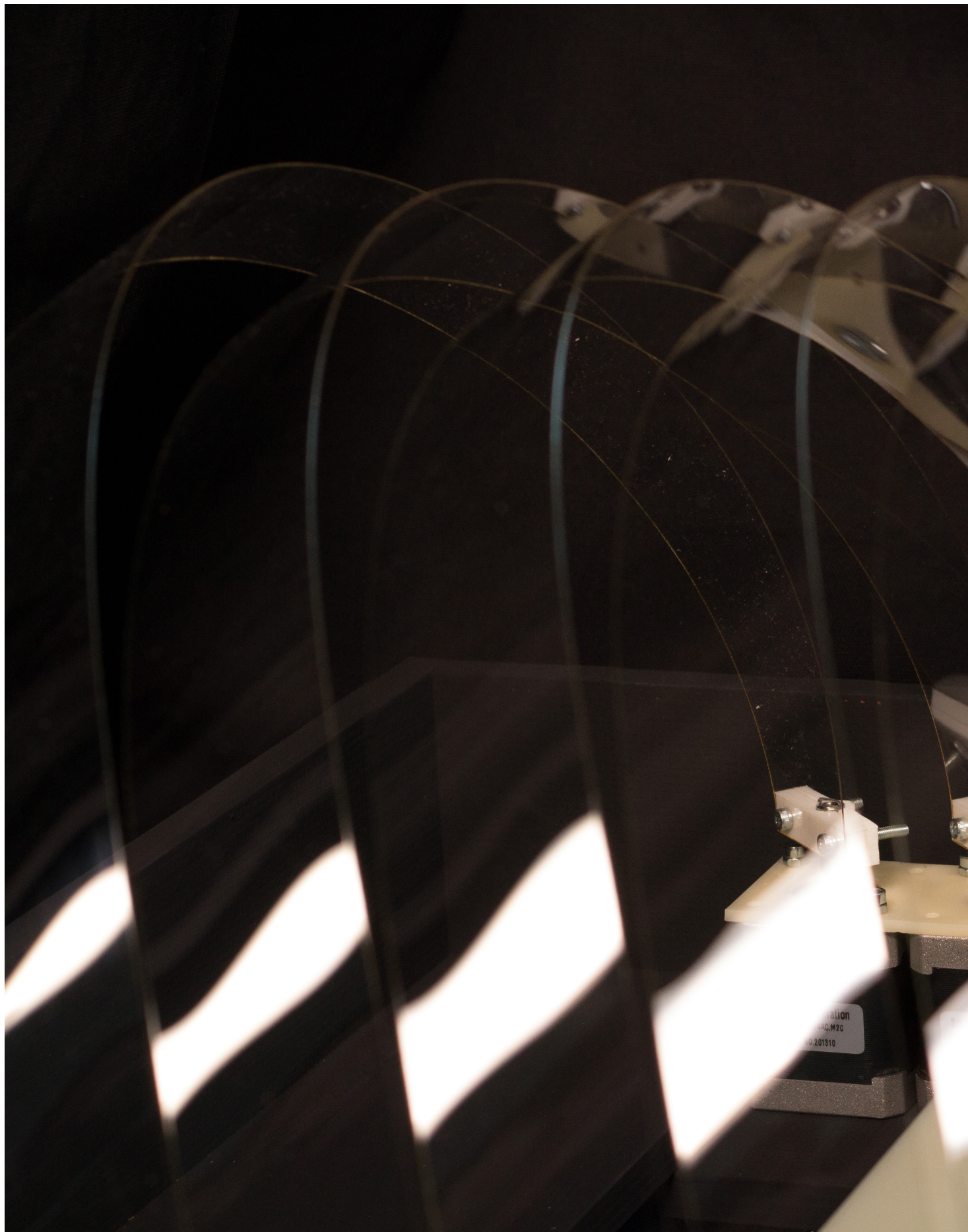



## 3.2.7 Assembly



**3.25** Assembly station in Intermedia Lab.

The final prototype was assembled in a number of steps and covered several months with some shorter sprints and longer intermissions. I assembled the prototype myself with few exceptions. The fabrication was all conducted at IT University in Intermedia Lab (figure 3.25), where the prototype was placed, and in ITU's maker space, which hosts an Epilog Helix laser cutter with a work area of  $600 \times 450$  mm. The assembly concept was to construct for change. This meant that, ideally, all the components could be demounted and changed for other components in order to make changes to the prototype at later stages. Practically, this involved the use of bolts and screws, for instance, rather than adhesives. With the extended layering of components on top of other components, in reality it becomes increasingly difficult to replace parts at the bottom without removing parts on top. However, the approach has paid off, as various parts of the drive system have been upgraded after the initial construction.



**3.26** Mounting box frames to truss system.

For the base structure of the prototype, I would be using the Prolyte truss structure modules that were available in Intermedia Lab. Prolyte is an aluminium system developed as stage technology but with applications in a wide range of temporary structures. Prolyte is a system with straight sections of various lengths and corner and end pieces. A connection between the modules is achieved by means of couplers, spigots and safety R-springs. After considering various configurations, I settled on an integrated structure of a closed square at the bottom, with four vertical elements at the corners, connected at the top by two horizontal elements. This provided an approximately one-metre-high pedestal for the arches on opposite sides, while the other ends were open so that the space could be entered from two sides. A raised floor would cover data and power cables, and a computer.

### Integrated Boxes



**3.27** Stack of turntables.

Timber boxes were constructed as a frame from  $55 \times 15$  mm planks, acting as an intermediary layer between the aluminium trusses below and the turntables, drive mechanism and arches above (figures 3.26 and 3.30). Each box measures  $300 \times 600$  mm in plan and was designed over various iterations as an integrated piece. The boxes were assembled in their final position on the truss. Four frames on each side were laid out and aligned on top of the truss before being fixed in position. A transparent acrylic top plate was placed directly on top of the timber (figures 3.31 and 3.32). The top plate is 6 mm thick and has cutouts for the turntables, the stepper motors, and for screws and bolts. The large circular cutouts measure 294 mm in diameter, which is 75% of the material. This material is used for the cogs (figure 3.33), forming the core of the turntables, and for the spacer plates for the stepper motors. Stepper motors are positioned under the top plate and fixed to the top plate with four M3 bolts in slotted holes. This allows fixation of the stepper and tensioning of the drive belt at the same time. A 6 mm spacer plate is used to correctly position the stepper motor so

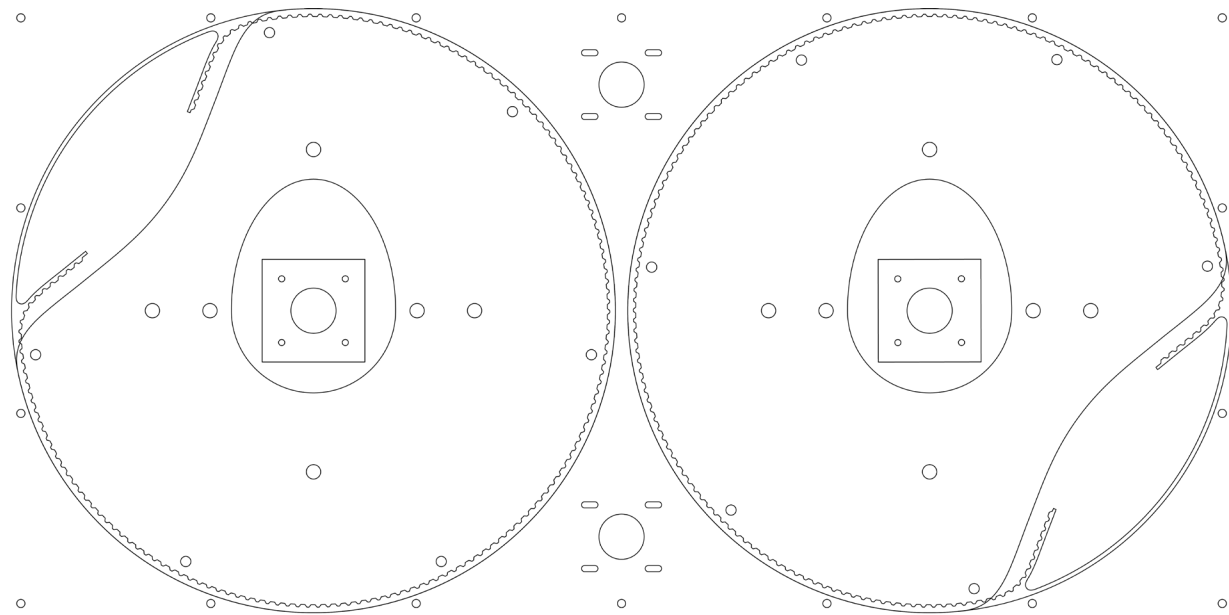

3.28 Turntable laser cutting pattern.

3.29 Overview of parts of the integrated box.

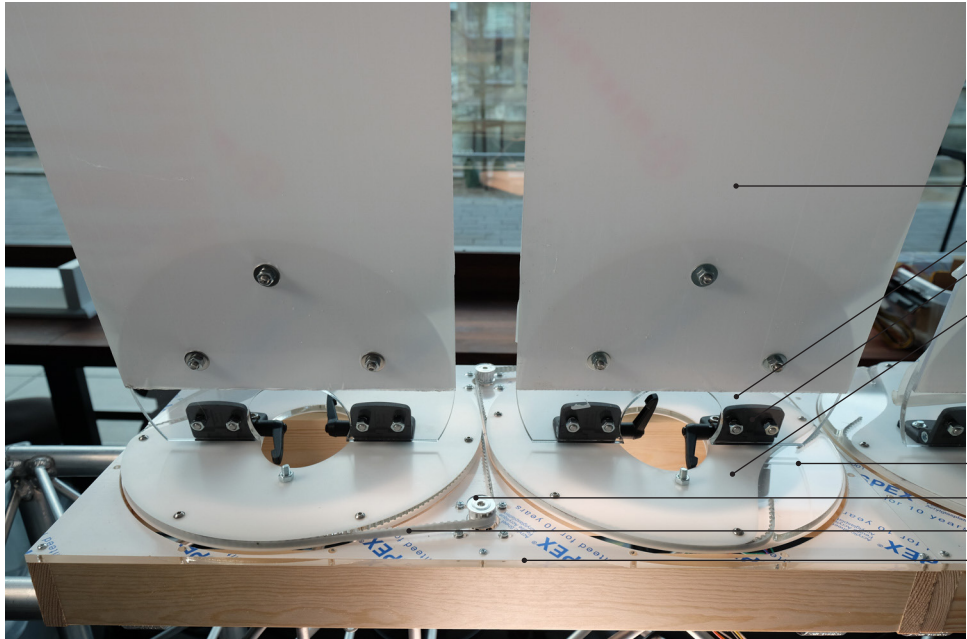

- strip (in protective film)
- holding plate
- adjustable hinge
- top flange
- cog
- drive pulley
- timing belt
- cover plate (in protective film)



3.30 Box frame assembly.

3.31 Top plate before assembly.

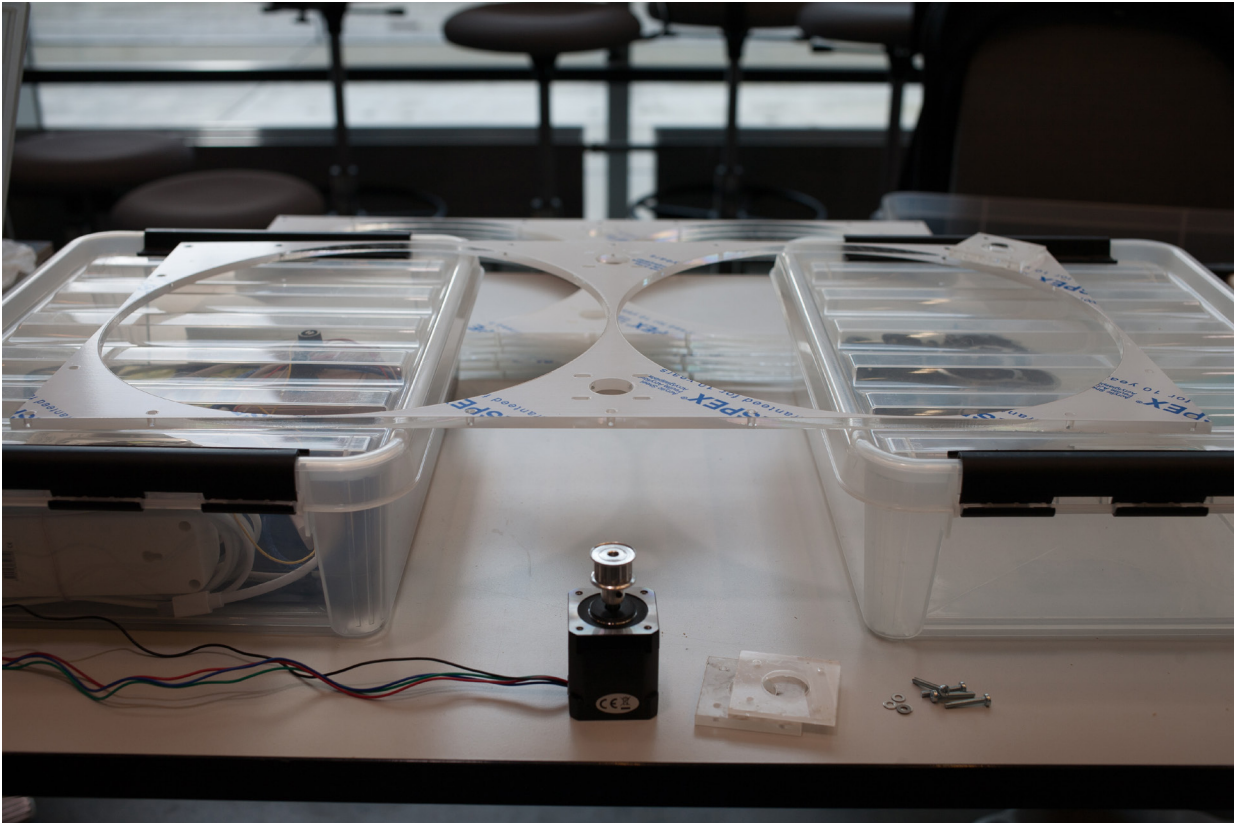



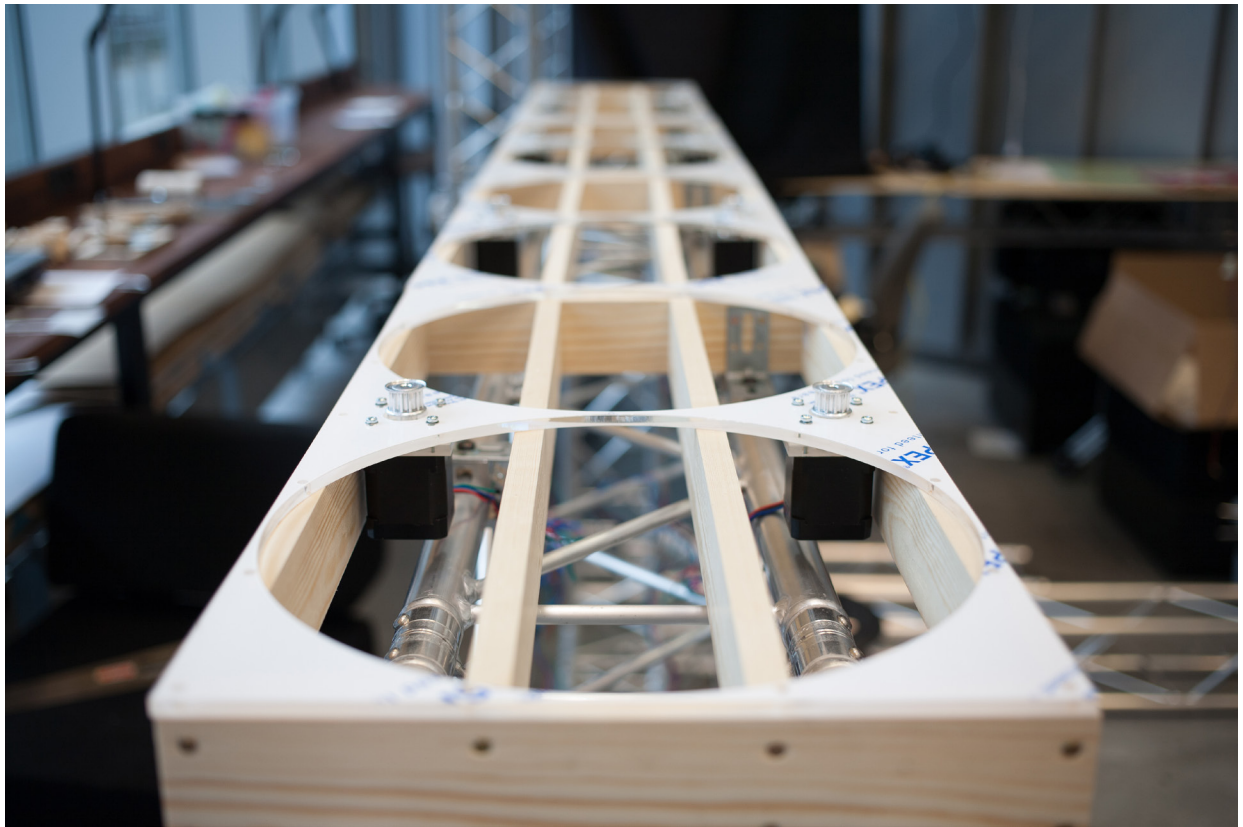

3.32 Top plates installed.

3.33 Turntable assembly.



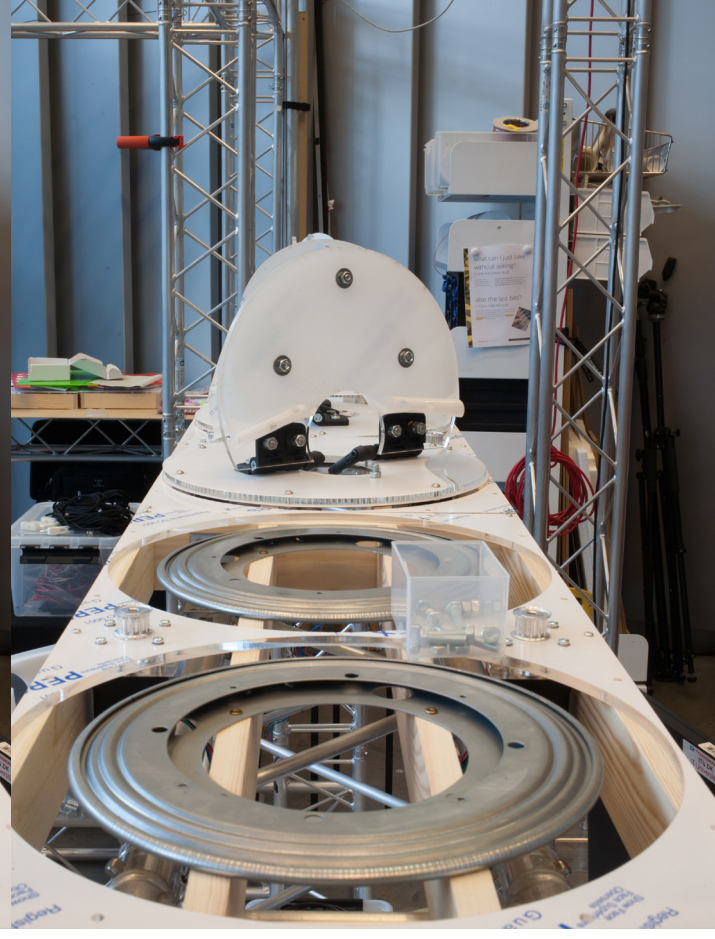
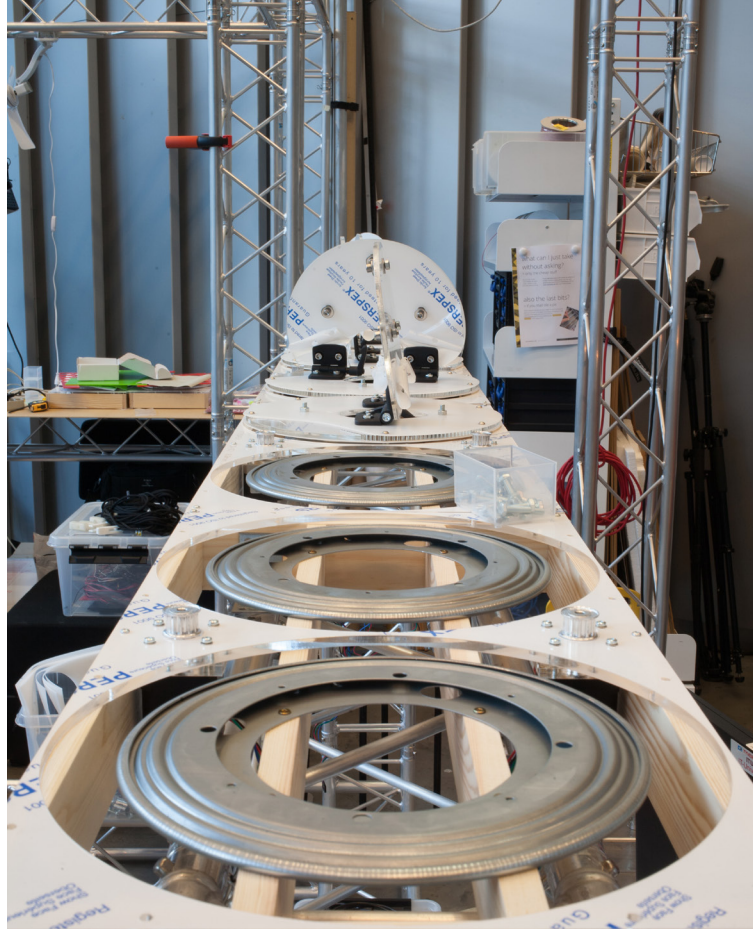

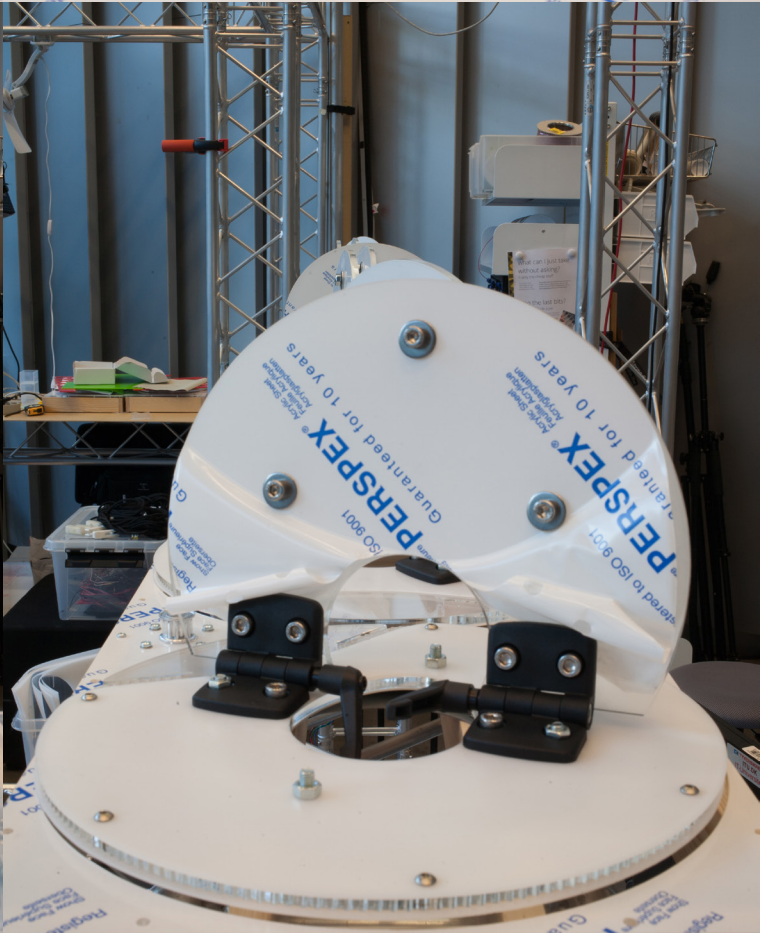
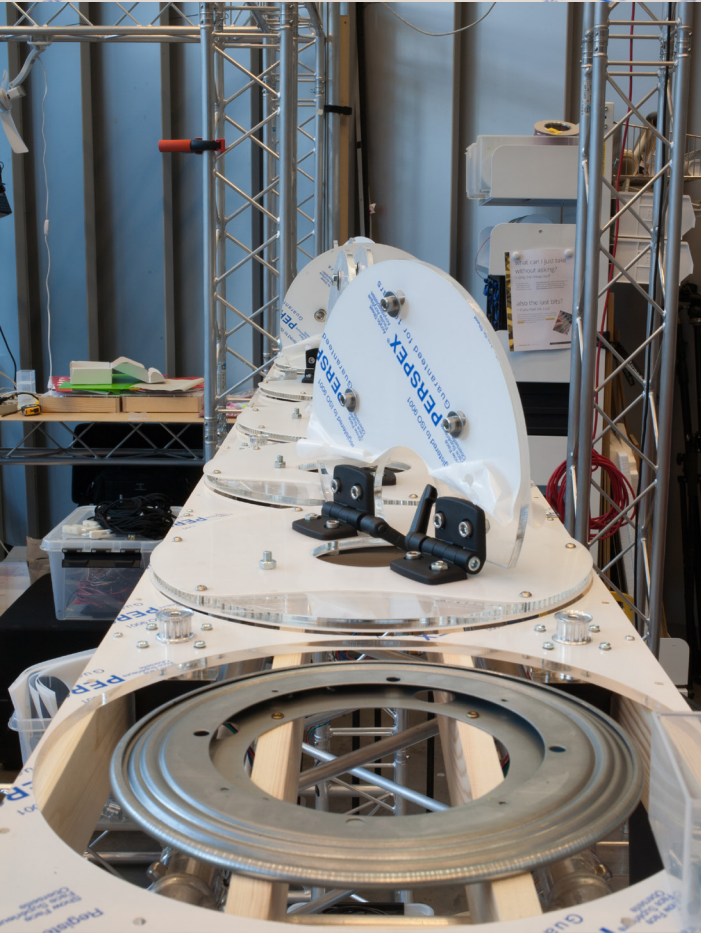

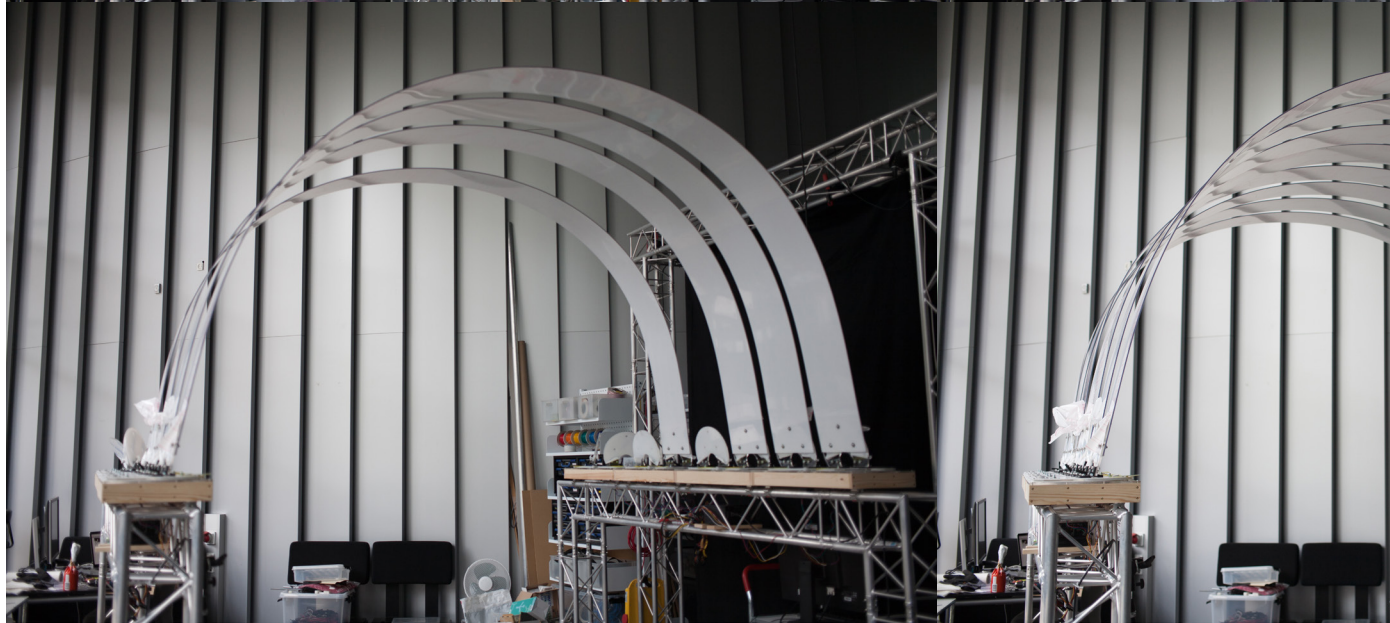
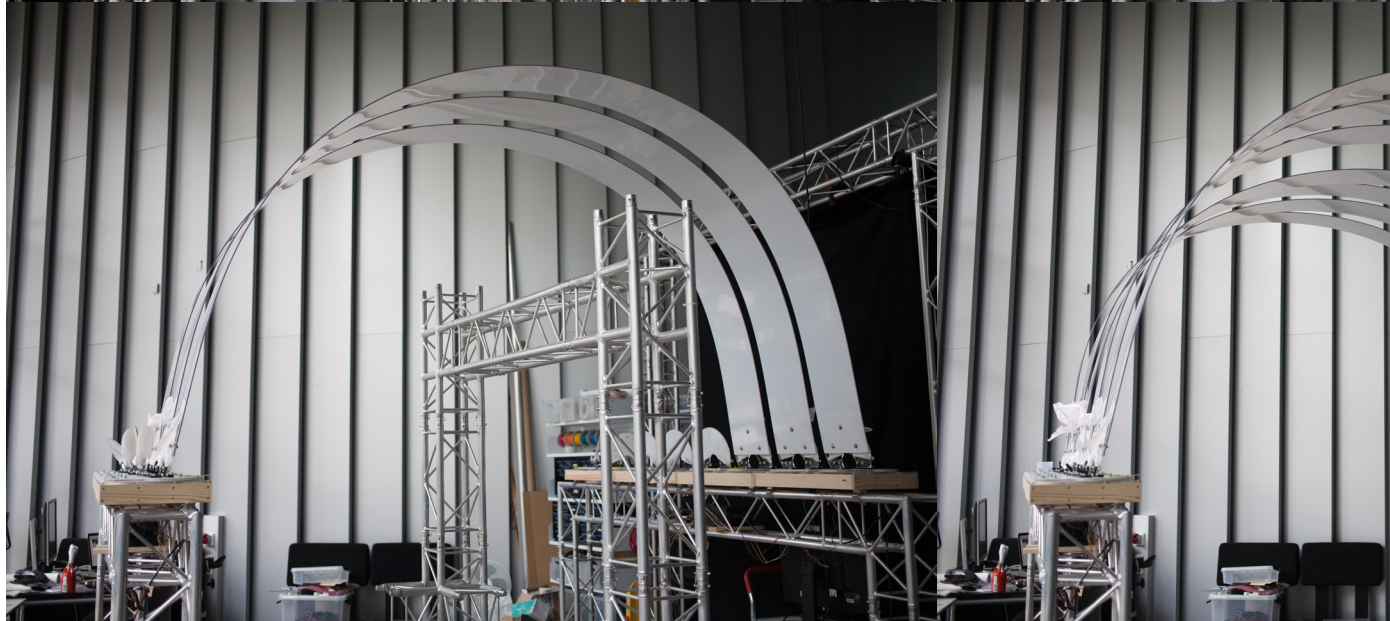
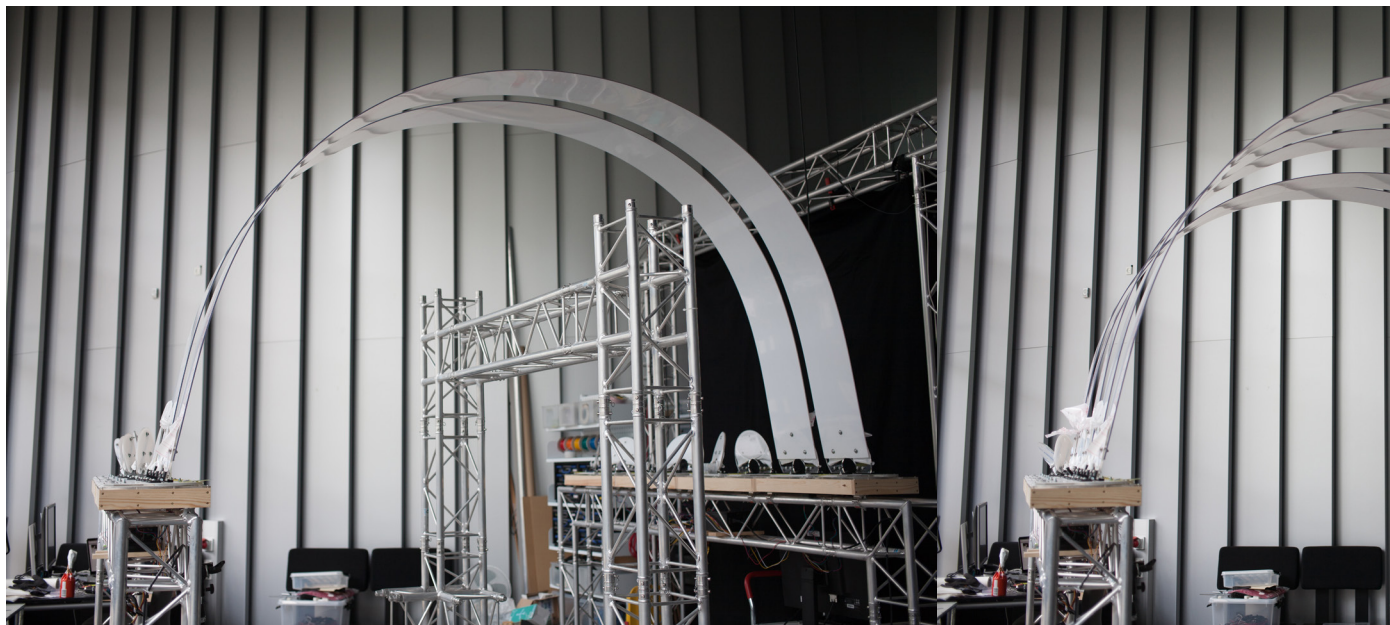



that the drive pulley aligns with the cog. Inside each large circular opening, a 225 mm-diameter Lazy Susan bearing is placed and fixed to the timber.

The turntables were assembled from the cogs that were cut from the 6 mm acrylic top plate, and from a bottom and top flange of 1 mm POM. The cogs are cut for a T5 timing belt and have teeth along three quarters of their circumference. This sufficed, as the turntables are never supposed to turn a full revolution as the maximum angles of the arch footing are set at  $60^\circ$  in either direction. A slot to lock the timing belt is cut on both sides of the teeth to avoid the need to close the belt and thus for ease of installation. The top flange therefore leaves the locking slot open. Each box has two different turntables, oriented towards the position of the stepper motor (figure 3.29).

The layers of material were assembled and fixed in place with a row of six bolts around the circumference of the turntable. On top, two Kipp hinges with a locking lever were mounted, initially with a single bolt. In order to connect the turntable to the Lazy Susan bearing, four bolts were required, two of which would double as the second bolt fixing the hinges. The central hole of the turntable is oval to accommodate the locking lever.

A packaging study for the boxes had been conducted in SketchUp in order to optimise the placement of all components. A previous version of the box that was 300 mm wide and 400 mm deep had been constructed to test the activation of a single strip. The intention was to produce sixteen such boxes for the full prototype, but during a refinement that was made for the Arup glass proposal, I reduced the depth to 300 mm and moved the motor to the side. By mirroring this arrangement for its neighbour, two systems could be nested on a  $600 \times 300$  mm area. A further benefit of this arrangement was that the cogs could be made slightly larger relative to their centred position in the first version, increasing the torque of the drivetrain. All the cuts had been prepared parametrically in Grasshopper in order to easily adjust hole positions, curves and cog teeth on a custom path. In order to ensure alignment of the bolt holes, these were drawn once and reused in several cutting patterns (figure 3.28).

## Strips

After the turntables were assembled, the holding plates were mounted on the hinges. The holding plates provide some stiffness to a short section at the bottom of the strip to increase the stability of the arch and to have a means of introducing the torque. The holding plates were cut from 6 mm transparent acrylic in a circular form, after several other forms had been considered that would reach higher up the strips. A central hole in the holding plate allows for free movement of the hinge-locking levers.

The installation of the assembled turntables on the Lazy Susan bearings was followed by the installation of the drive belts. The

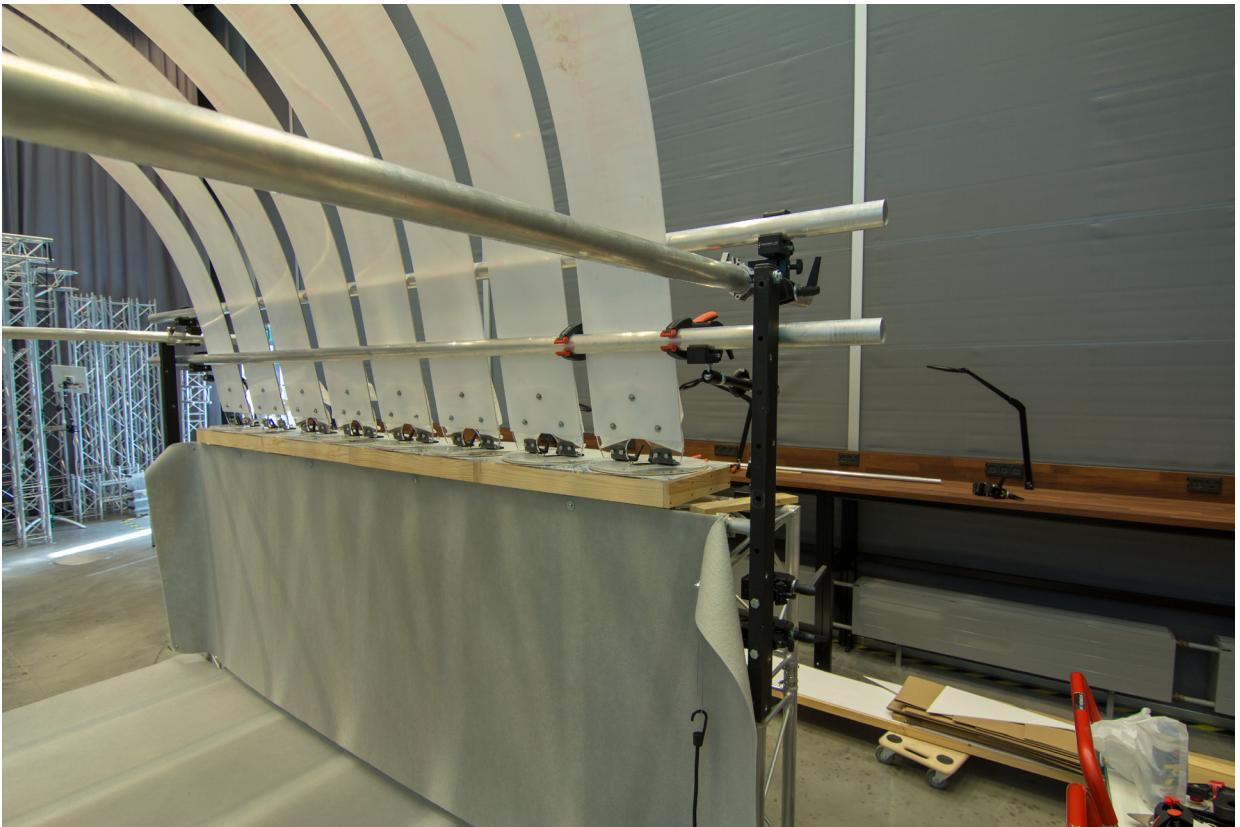

3.36 and 3.37 Adjusting strip position and alignment.

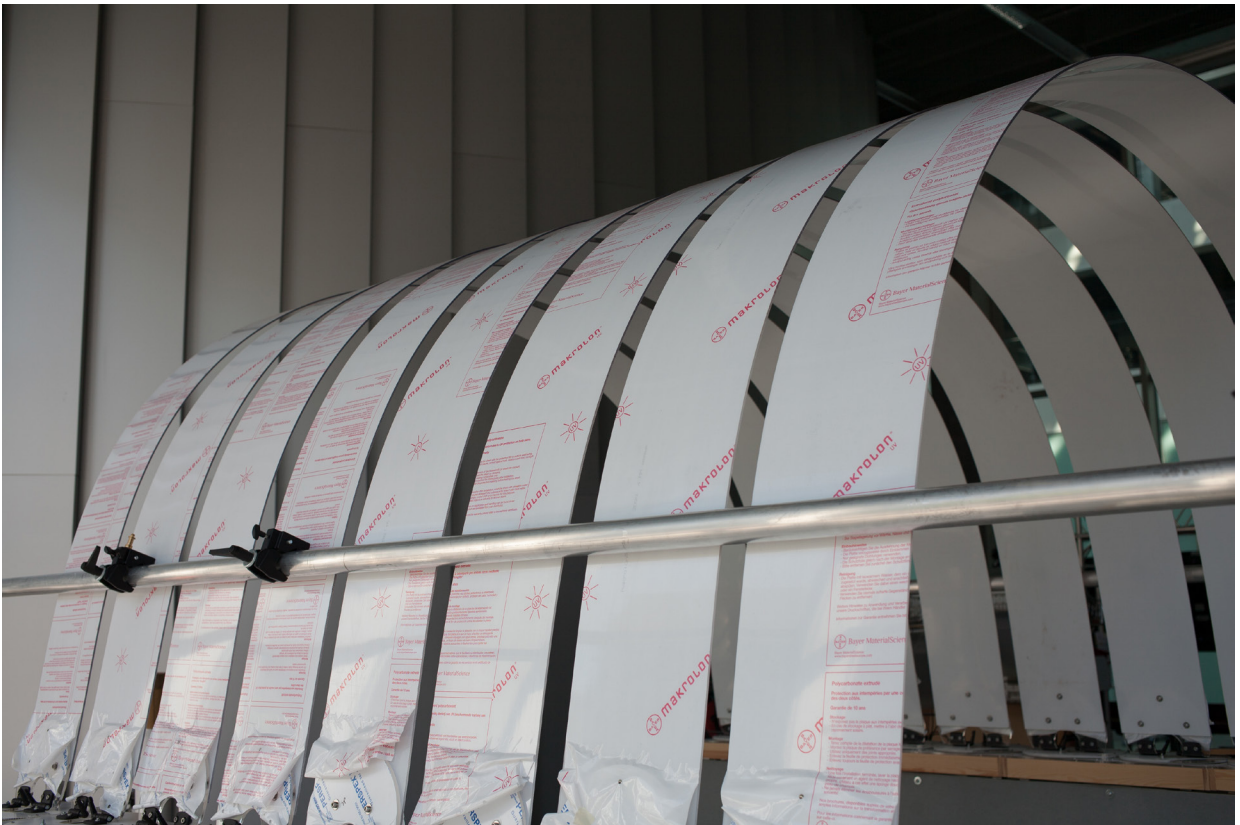

**3.34** (page 112-113) Turntable installation sequence.

**3.35** (page 114-115) Strip installation sequence.

belt tension was set coarsely by positioning the belt in the locking slot, and more finely by positioning the stepper motor. The control system was then tested to see if all motors were addressed correctly.

The strips were prepared lying flat. A template had been laser cut to drill three holes on each side, taking into account specific guidance from the supplier on minimum edge distance of the holes.

Installation of the strips took an extra pair of hands. Although the material is 4 mm thick, the strip length makes them unwieldy and they require careful handling. Three bolts on each side fix the strip to the inside of the holding plate. After the connection was made, the hinges were set at approximately the correct angle and locked. Their angles were set to higher precision after eight strips were installed, in order to align the strips (figure 3.35).

## Alignment

Alignment of the strips proved to be a demanding issue. The reason for applying adjustable hinges was to set the starting angle of the strips in the prototype. Various factors had influenced the shape of the arch that had not been fixed or would remain variable, such as the exact spacing of the footings, the dimensions of the holding plate, and the play in the Lazy Susan bearings. Also, the exact behaviour of the strips while twisting would depend on the starting angle to an unknown degree. However, leaving the starting angle as a variable also brought with it some room for human error in adjusting.

An unintended consequence of a change in the design during production was that the hinges could not be easily operated. In order to reduce screwing actions, the internal planks of the box frame had been rotated by  $90^\circ$ , and were now blocking the levers. The levers could be operated, but doing so required two hands. Therefore, adjusting the strips required two people.

The dimensions of the holding plate also affect the adjustment process. First, the shorter the holding plate, the more flexible the remaining strip becomes. And second, a shorter holding plate is harder to adjust accurately, and any movement of its tip results in larger effects on the shape of the arch.

A temporary scaffold was used to align the strips after their installation, but upon its removal, variations immediately became visible nevertheless. To reduce the variation that was brought with the adjustable hinges, a next iteration of the prototype would seek to implement hinges that could be adjusted only at fixed increments. This would allow the variation required for adjusting strip performance in a prototype, but would reduce one variable from the system. Further investigations could focus on possible deformation in the polycarbonate due to bending or creep. This is visually not observable in the bent condition and may need inspection of the strip on a flat surface. There is also some possible misalignment due to the fixation holes in the strip and the holding plate being oversized.





It should be noted that the variations in strip adjustment are less pronounced when the strips are actuated. The twisting at the base forces the strips into a shape that has an increased geometrical stiffness, taking away the variations due to flexibility of the strip itself, and finding the form dictated by its constraint conditions. The problem of misalignment disappears completely when the strips are excited by wind and irregularity is part of the expected pattern.

## White Revisited

Dust was expected to settle on the strips quite soon, as once the protective layer of plastic was removed from the polycarbonate, the surface would have a static electric charge that would attract dust. This was the reason to only remove the plastic when everything else was working and the prototype could be documented. The strips would move just as well for testing with the thin layer intact. The consequence of the white protective plastic was that the prototype has been documented with white strips before they were made transparent. This allowed for a revisit of the original decision about transparency.

In a darkened Intermedia Lab, and with a directional lighting setup, the white strips provided a high contrast image (figures 3.38–3.40). However, because of the lack of context in the dark situation, movement of one strip was relevant only in relation to the other strips. This effect was intensified by the uniform whiteness of

3.38–3.40 Prototype in white (with protective film).



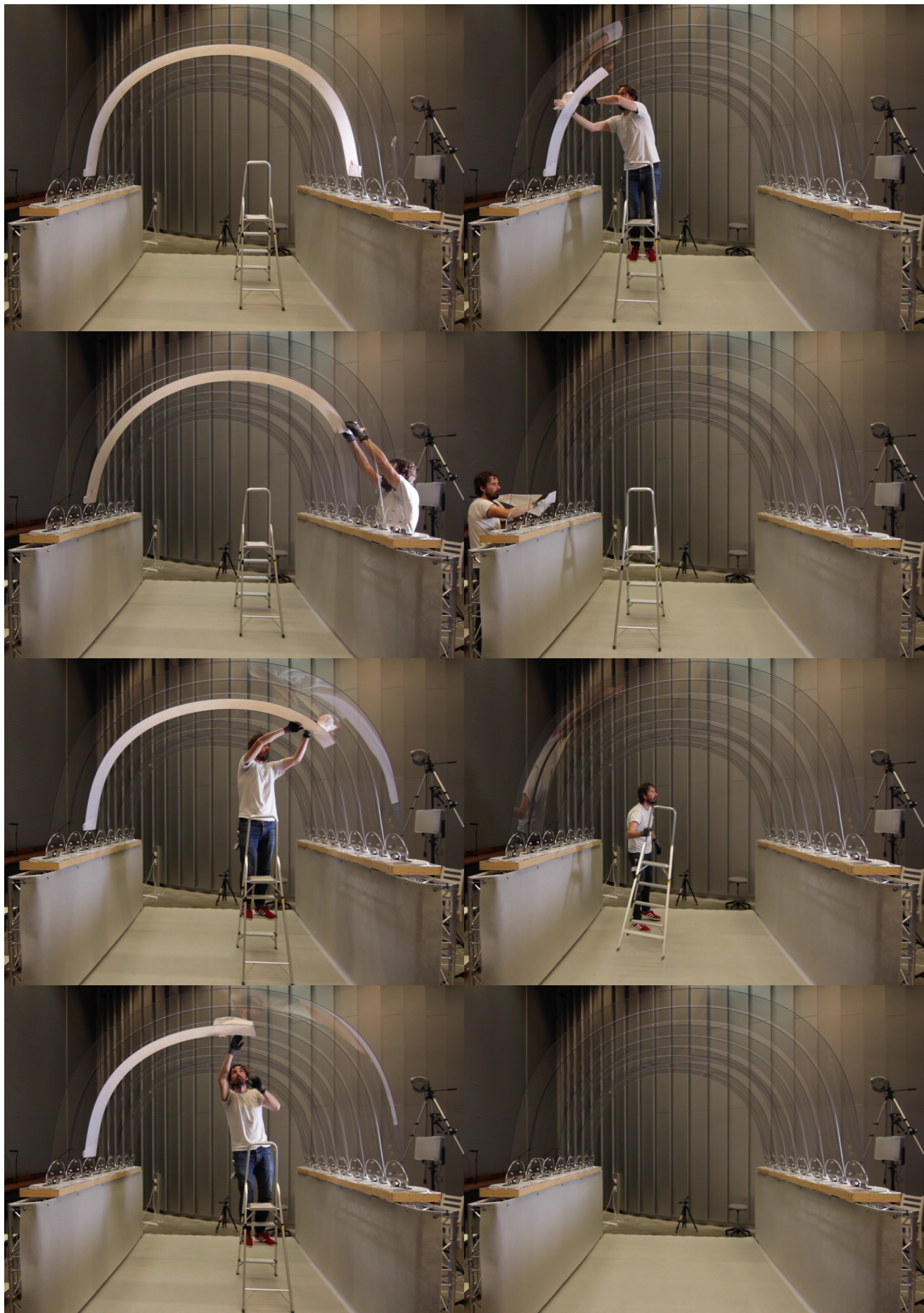

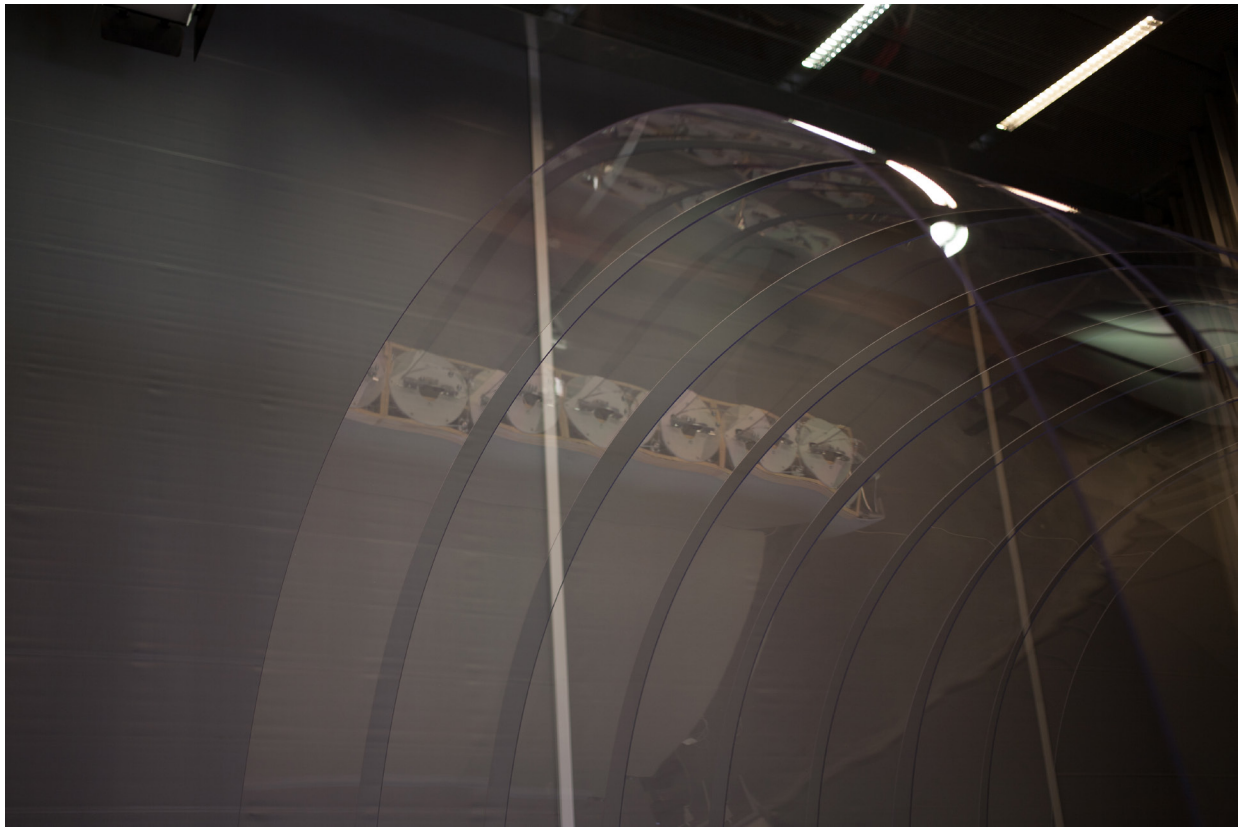

**3.41** Removal of protective film.

**3.42 and 3.43** Prototype after removal of protective film.



the strip that was lacking nuance and was barely reflective. In long exposure photographs, movement became visible as a blurring of the strip edges, but in direct experience it was harder to discern. The small vibrations and detailed movements that became visible later in the transparent strips were lost in the whiteness.

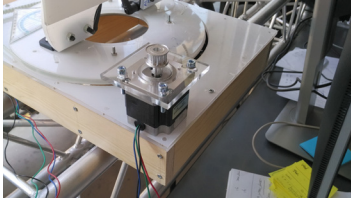

**3.44** Stepper motor (shown is NEMA 23).

## Drive Power

From the test that was conducted with a single 4 m polycarbonate strip, it was clear that the selected motors would be close to their capacity. At relatively small rotation angles of  $25^\circ$ , the motors began to stall. One solution could have been to upgrade the NEMA 17 motors to NEMA 23 (figure 3.44) with higher torque, but this would have had effects on the control system, the budget (motors and pulleys had already been purchased) and box layout. Therefore, the solution was sought in increasing the cog dimension. This would increase the torque that could be applied by the drive system. After the prototype was installed, further changes have been made. The drive pulleys have been changed from 14 teeth to 10 teeth, further increasing the output torque of the system. The drive belts have also been changed. The first installed belt was 6 mm wide and tended to scrape along the flanges of the turntable, causing increased friction. As the belts are reinforced with steel cords, efforts to reduce the width manually led to steel splinters protruding from the material, making the drive situation worse. It was replaced with a 4 mm-wide belt. With these adjustments, the turntables could now be turned to  $45^\circ$  angles in either direction, which had been the goal. It has also been suggested that the potentiometers on the motor drivers could be adjusted to allow more current to run to the motors, but with the prototype running satisfactory, this was not further pursued.

## Control System and Interface

The control system used in the prototype was developed on the scale model and was duplicated in the prototype with no other alterations. All stepper motors are 2-phase, bipolar motors that are common in 3D printers. The driver configuration is copied from a RepRap 3D printer, using four A4988 motor drivers on a RAMPS 1.4 shield, on top of an Arduino Mega. On each side of the arches, two of those sets and an Arduino Uno are linked by an I<sup>2</sup>C bus. The Arduino Uno, as I<sup>2</sup>C master, is connected to a serial port on a laptop (see diagram in figure 3.45 and figure 3.46). It was decided early in the process, for maintenance reasons, to keep the code on the boards as simple as possible and to use Processing on the laptop to develop the scripts for forming patterns. Therefore, the boards only relay information to the relevant stepper motor. The Uno master board unpacks a string of information from serial communication and repackages it for I<sup>2</sup>C; the Mega slave boards unpack the I<sup>2</sup>C data and repackage it to control the steppers.

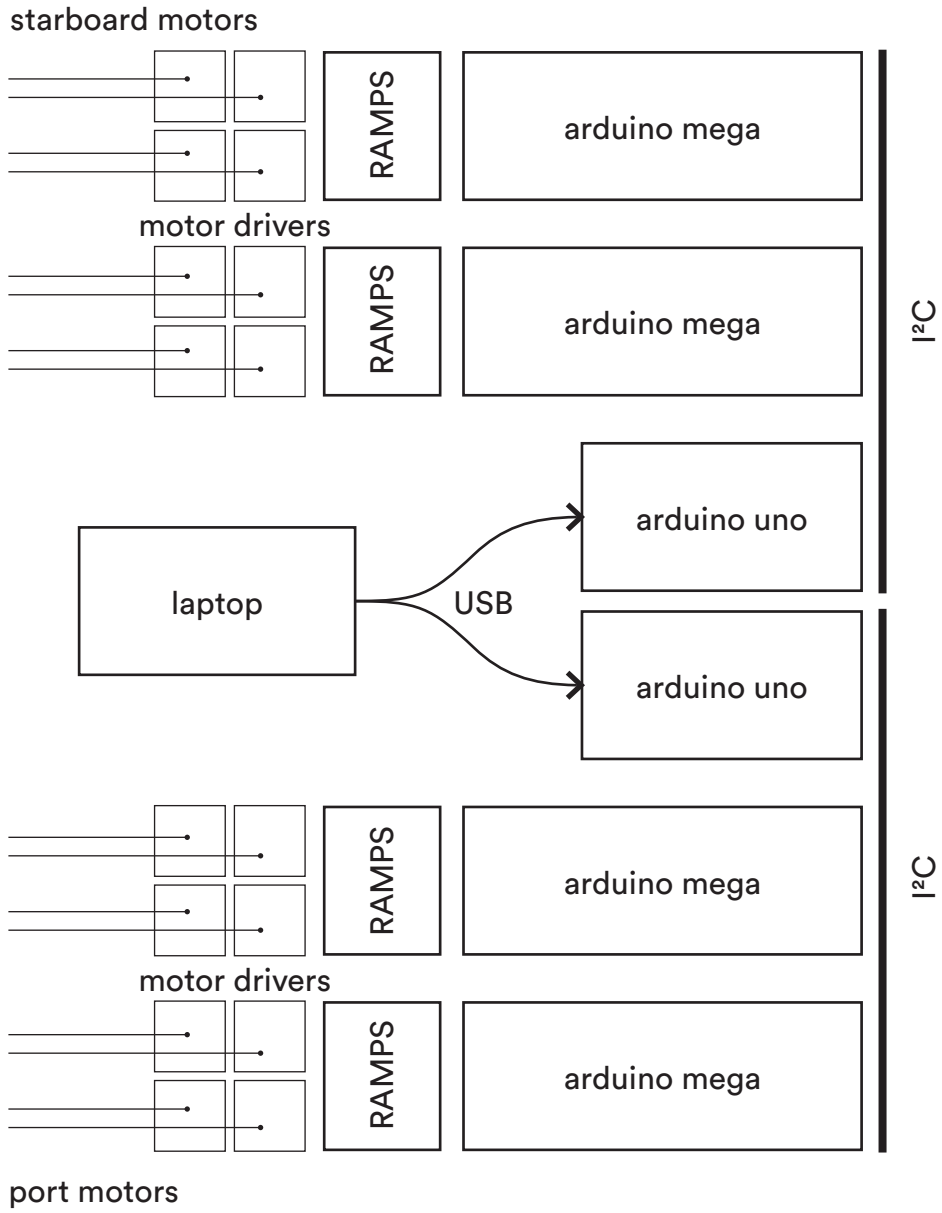

3.45 Control diagram.

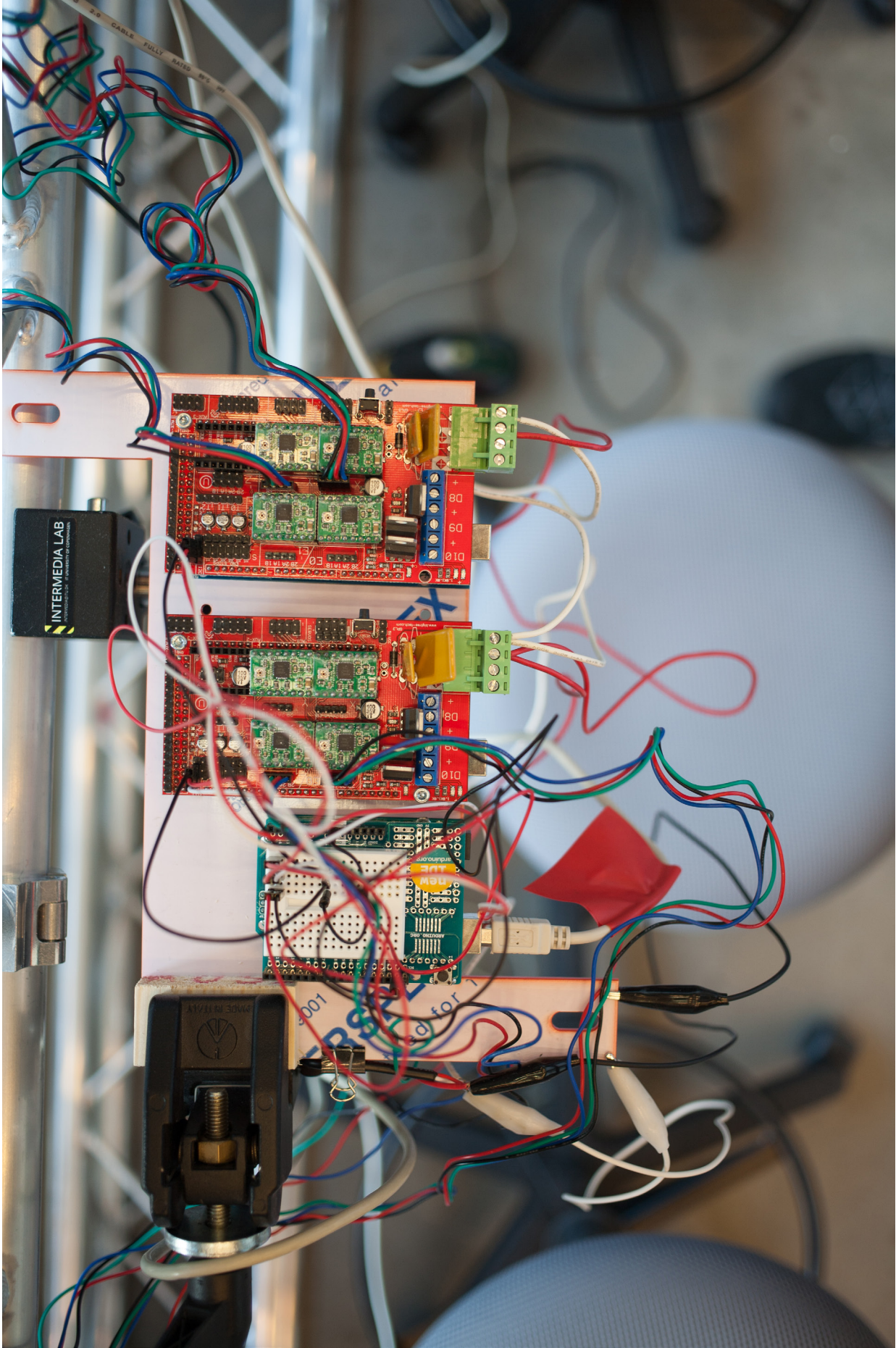

The slave boards run the AccelStepper library (McCauley, 2010) so that motors can simply be setup with values for acceleration, maximum speed and their goal rotation, measured in steps. This process remains responsive, therefore if another instruction is received partway through an execution, the motor's course is updated.

The Processing script uses the controlP5 library (Schlegel, 2011) for the creation of a simple GUI with sliders, buttons, and checkboxes (figure 3.47). The interface provides some sliders for acceleration, speed, amplitude and interval, assuming a cyclic back-and-forth movement. Strips can also be individually addressed, and a specific angle set. Note that the interface addresses strips not motors. The control logic only allows the two motors of a strip to mirror their rotations in order to move the strips.

There is no feedback from the motors, which means that new instructions just override old instructions. Consequently, if motors stall on reaching their maximum torque, they must be reset, which requires all motors to be powered off and the strips to be readjusted. There is also no built-in collision check, which means that strips need to be carefully instructed in order not to collide with neighbouring strips. To facilitate this, a number of functions have been written for standard patterns and moves that can be activated through a button, with an optional setting for cyclic movement.

3.47 Graphical User Interface for motorised strip movements.

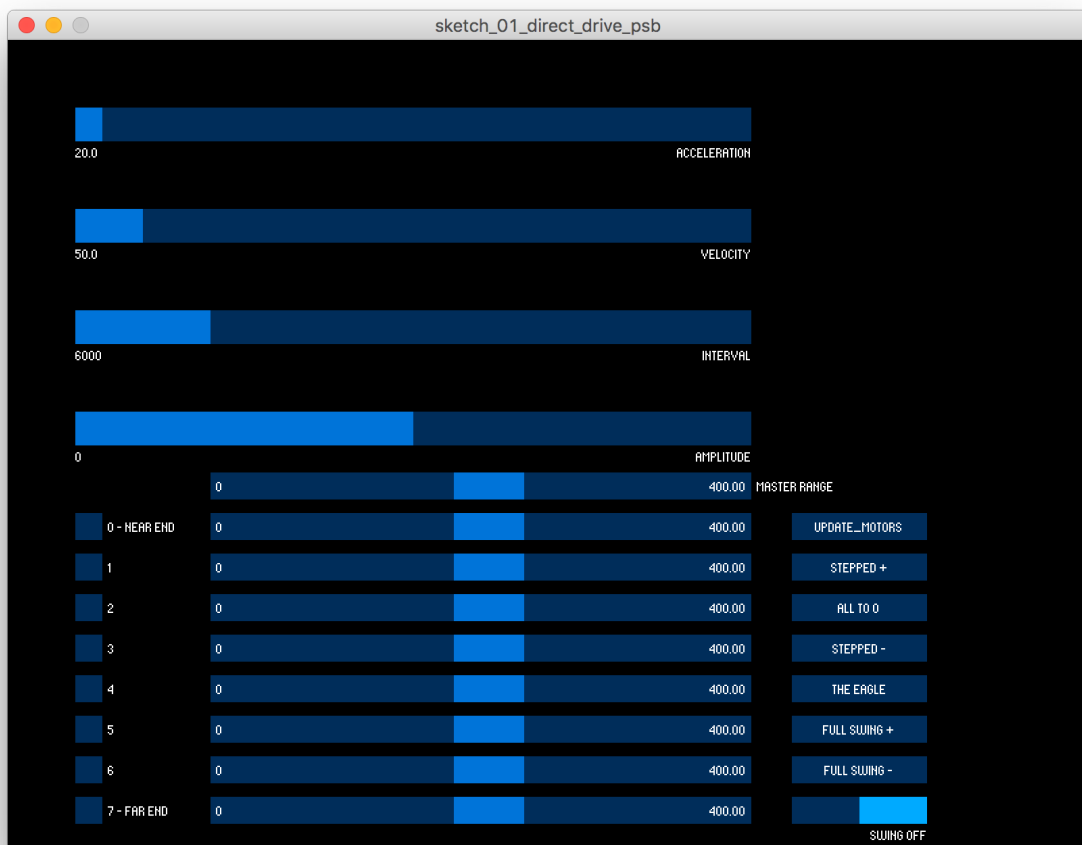

## 3.3 Associated Hypomnesic Milieu

The prototype has been framed as a tool for thinking in section 3.1. Bernard Stiegler's philosophy about technics as exteriorised memory gives us a theoretical context to unpack this idea. Both the process of prototyping as well as the prototype itself are critical elements in that analysis—the first as a cognitive process, the second as coded memory.

*Hypomnesis* is what Stiegler calls “recollection through externalized memory” (Stiegler, 2010, p. 76). He develops a more encompassing notion of the *hypomnesic milieu*, that I apply to the prototyping environment, understood as the prototype in the making, including the digital design environment.

Stiegler's thesis aligns with my own intuition, shaped by years of design practice, about the significance of sketching, tinkering, making, or prototyping as thought that develops meanders between internal (living) and external (technical) processes. And his thinking highlights the importance of a dynamic equilibrium that favours neither technical know-how nor technical memory. Stiegler calls this balanced condition a *sustainable* hypomnesic milieu.

In the following subsections, four modes are identified in which hypomnesis has manifested itself in the prototyping process and how these modes contribute to a sustainable hypomnesic milieu.

Subsection 3.3.1 discusses the most direct exteriorisation, which is the memory aid, or to use Stiegler's parlance, the mnemotechnique. Together with situated symbolic annotations, which are more explicit, memory aids may be permanent, but are mostly relevant during the production process.

Subsection 3.3.2 presents the prototype as a construction that allows for thought to build on other thoughts—a stepping stone. The analogy with drawing is used to show how thoughts can be kept in view, to build further on them.

Subsection 3.3.3 positions digital fabrication as a form of grammatisation. On the one hand, digital fabrication removes the need for certain fabrication skills, but the internet enables a deep understanding that replaces it with productive know-how.

Subsection 3.3.4 discusses the prototype as an enabler for communication across disciplinary boundaries. The prototype may ultimately represent the specific concerns projected by an observer, but it remains there as a physical object that is the shared starting point giving rise to those concerns.



### 3.3.1 Mnemotechniques and Literal Annotation

The first of the hypomnesic modes is the use of simple memory aids. Hypomnesis is induced by placing items, such as screws, nuts and bolts at meaningful locations, such as where they should be installed. Before they perform their primary function, these items act as mnemotechniques, to help the installer remember where work needs to be done (figure 3.48). And sometimes a tool, such as a tape measure or a screwdriver, acts as mnemotechnique, for example when it is placed somewhere to remember a particular task or sequence. Repetition was an important reason for using memory aids. As the eight strips and their rotating bases are identical, it was easy to forget which strip a particular task should apply to. The two strips on each side were easy to identify based on them being edges and adjacent to edges, but the four strips in the middle could be easily confused without some sort of marker (figure 3.49). And for the assembly of the turntables, which was repeated 16 times, all the components were laid out for assembly in order to avoid forgetting parts in the process. Mnemotechniques, as described here, had a function during the process of prototyping, but lost their function as a memory aid after being installed. More permanent aids can be found in the colour coding of the port and starboard controllers, which have red and green mounting plates and wire markers (figure 3.50).

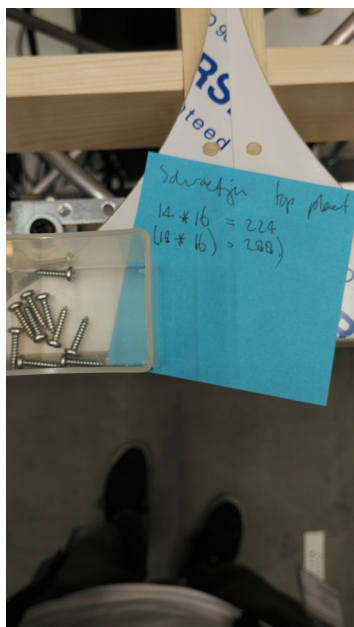

3.48 Screws placed to remember next step of installation process.

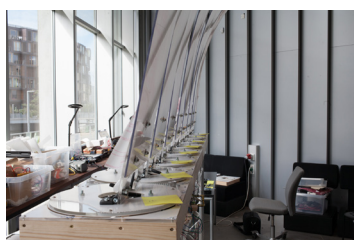

3.49 Post-its help distinguish individual strips.

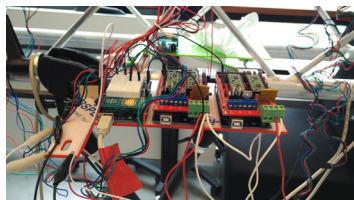

3.50 Coloured base plates aid identification of port and starboard sides.

In line with this, is the use of literal annotations, which involves writing comments on the artefacts situated where they apply. This is an aspect that also mainly applies to the production process of prototyping. Essentially, it is nothing other than writing, but the writing is being given additional meaning by a context. Therefore, often annotations are brief, because the lack of direct meaning is complemented by the surrounding context. A number written on a component could refer to a dimension, to the number of holes to be drilled, or to orientation, for example (figure 3.51). This technique has been used mainly in my process by writing with a marker on the protective plastic film covering the transparent materials and on Post-its on other materials to avoid leaving a permanent trace of the comments after they had served their purpose.

This technique is also frequently used by me in 3D modelling. It involves placing comments with *leaders*, which are arrows in 3D space that point to specific locations in the model. Literal annotation is common practice for construction workers annotating raw construction materials. Such scribbles sometimes remain visible on untreated surfaces of buildings (figure 3.52).

Like memory aids, the annotations appeal to other, living memories in order to be useful. They are part of a more complex thought process, which can be highly individual. Not everyone would interpret a scribble in the same way, or understand a memory aid as something actionable. But it is not difficult to see how such aids can become part of a shared practice, forming a language in itself that allows for some form of communication and task sharing between multiple prototypers.

## 3.3.2 Stepping Stone

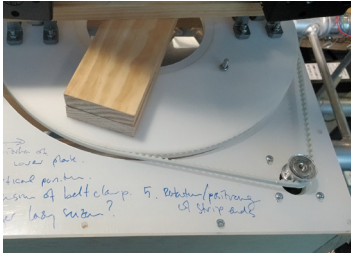

3.51 Notes written directly on the work in progress.

The second mode in which the prototype supports thinking is as a stepping stone for thought. This applies to the process of prototyping itself, as well as to the larger context in which the prototyping takes place. Within the prototyping process, in a linear manner, this means that making one thing leads to the next. A produced artefact, such as a holding plate, will give feedback about its performance. Making it too long may lead to a holding plate that is visually less attractive and that provides too much stiffness to the strip. Too short, and the strip may buckle through lack of support. In contemporary engineering practice, such feedback would often be derived from computational simulation, where, similarly, the outcome would be a stepping stone in an iterative process. And more generally in the design process, the drawing might perform such a function in a developing process. A specific example is a series of six drawings by Peter Cook, called the *Veg House*, where the aim of the drawings is to evolve. He writes:

**For me, there is the delightful experience of carrying out a process that can enhance the primary decisions (of size, position, figure or direction), with such a mobile and extensive addition of evidence. It is as if the first part of the illustration is being illustrated by the second. (Cook, 2014, p. 172)**

The drawing allows for the construction of something that cannot simply be thought. It needs to be drawn in order to draw the next part. Stiegler also discusses the drawing, by referring to the (slightly misrepresented) dialogue between Socrates and Meno, as told by Plato. In the dialogue, Socrates summons a slave and questions him about geometry, drawing a diagram in the process:

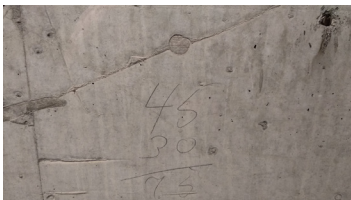
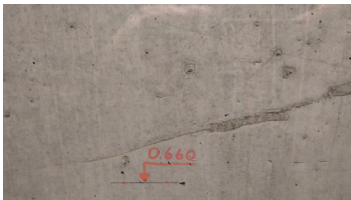

3.52 Marks left on building.

**The drawing, as hypomnesic memory, is therefore indispensable to this potential philosopher, the slave boy, and to his passage into action, that is, his anamnesis. It constitutes a crutch for understanding, a space of intuition entirely produced by the gestures of the slave tracing in the sand the figured effects of this reasoning. The sand holds “in view” the results of the slave’s intuition and understanding; it thus facilitates the extension and construction of the geometrical proof. (Stiegler, 2010, p. 74)**

Therefore the drawing, and in my interpretation both the 3D digital model and the physical prototype, lets us keep *in view* a certain understanding. Beyond being a series of stepping stones, each leading to the next thought, the prototype is the construction of a thesis with a complexity that can only be developed through structured exteriorisation.

## 3.3.3 Digitisation of Fabrication

The third mode of exteriorisation is the digitisation of fabrication. Not just in the form of the tool as a prosthetic that is the 3D-printer,

or the laser cutter (figure 3.53), or the CNC-router, but by taking away a mental step between drawing and making. Stiegler writes about driving a car:

**[T]he more the automobile is improved, the less we know how to drive. Eventually, the GPS driving assistant will replace the driver altogether; we will lose control over our own sensory-motor schema as such guidance becomes automatic, a formal element of the navigation system. (Stiegler, 2010, p. 68)**



**3.53** Laser cutting prototype components.

The digital fabrication tools at this point still require a significant amount of know-how to operate well. Although their reach has increased well beyond a small group of expert users, they have arguably not yet lived up to the promise of bringing these technologies to the masses. This may change over time, taking away what is left to know about materials and to understand of the process. For the users of digital fabrication tools, the direct link between a digital drawing and the production of an artefact has already removed the necessity to master a manufacturing skill. The precision of most of these tools out-does most humans, so it is not only removing the control of the sensory-motor schema as Stiegler writes but removing the incentive to learn that control in the first place. In this sense, digital fabrication is both an enabler and a threat, a *pharmakon*, that enables humans to reach further, while at the same time taking away a certain capacity. Stiegler writes about this as a *grammatisation* of gestures. Grammatisation, he explains, following Derrida, is the discretisation of the continuities that shape our lives. “Writing, as the breaking into discrete elements of the flux of speech [...], is an example of a stage in the process of grammatization” (p. 70). He writes that in the industrial age, know-how was transferred to gesture-reproducing machines, without an understanding of the workings of these machines. What makes digital fabrication in our current time different, is the culture that surrounds it of self-taught expertise. 3D printers can be partially 3D printed following online instructions. The workings of a laser cutter are easily found online and read-up on. Thereby, they do not just reproduce the same pre-programmed gestures, but they produce the gestures that they are instructed to by the user. The consumer is also the producer.

Stiegler describes this time as the “era of digital networked hypomnemata [that] inaugurates the industrial hypomnesic milieu” (Stiegler, 2010, p. 83). The digital fabrication technologies (but not just those) are in part powered by the Internet, providing easy access to information, training material and examples. Even access to existing machines is not a requirement, as many of the machines can be self-built in some form following detailed examples. Lively online communities of programmers and makers further ensure that those in need of help get the support they need to continue. We can understand Mark Goulthorpe’s words as particularly applicable for this type of Internet-enabled prototyping: “Prototyping ensures that, to some degree, invention displaces reliance on expertise - in other words, that there is a different set of drivers behind cultural production beyond the emulation of prior excellence” (M. Burry & Burry, 2016, p. 78).

### 3.3.4 Communication

The fourth mode of exteriorisation lies in the communication enabled by the prototype. Through its physical manifestation, the prototype is a particular expression of thought, laid out by the prototyper and available for interpretation by anyone who attends to it. This interpretation may take place on different levels, depending on the personal history of the interpreter. It may, to some, just be a visual object with a certain form and behaviour, like the alphabet would be for the illiterate. For others, who are more versed in its language, it may evoke associations linked to a professional field or practice. However, I would argue that it is less restrictive than a natural or formal language, allowing for multiple and diverging interpretations. In being a starting point, and not a conclusion, the prototype therefore becomes an enabler of communication across fields, and as we will see, across disciplines in academia and industry.

The existence of multiple interpretations may have been cause for confusion if the prototype was intended to illustrate a particular phenomenon. But it is not; the prototype has been an instrument to develop lines of thought, and it is enriched by the multiple understandings.

*Envir(On)ment*, as the prototype is referred to as an installation, can be read as the expression of a philosophical idea, similar to *The End of Sitting* (2015), an installation by RAAAF and Barbara Visser. In the short film about the installation, Erik Rietveld says that philosophers are used to creating their worldview in words, but that the installation is an experienceable, material manifestation of that philosophical worldview. Both installations thereby open up for an architectural interpretation about materiality, form, and composition. And in so doing, there is an engineering aspect concerning how it is made, how it works, and how it could work better. These aspects all have the same starting point, but fan out in different directions, each with its own concerns.

This is illustrated further through a spin-off project in collaboration with Arup and the glass industry. That project started as a conversation about the prototype when it was in an early stage, and the use of thin glass as material for the strips was suggested (see also the subsection on Transparency in section 3.2). Apart from a consideration of the material in the context of the prototype, it was also recognised that glass manufacturers were looking for opportunities to use this material in a building context. Currently, its primary use is in electronics. It was helpful to clarify the proposed application of thin glass, to frame the prototype as a demonstrator of an adaptive building facade with the potential to actively modulate internal climate conditions. These different concerns all share a common starting point in the installation.

## 3.4 Prototyping: Review

This section concludes the Prototyping chapter. Two vectors were set out in chapter 2 as indicators for the direction of research in this thesis. One vector is described as that of cognitive enactment, which is formulated by three concepts: coupling, acting out, and exteriorisation. The other vector is described as a fundamental type of architectural movement, structured movement, which is qualified as intentional, realised and beyond utility. By working with the prototype, as discussed in this chapter, the understanding of these qualifiers has been refined. The analysis of the prototyping process as a hypomnesic milieu has developed the enactive concept of exteriorisation.

Section 3.1 provides the setup for a speculative process of design and making. It introduces the prototyping process as a process of research by design, and frames the prototyping as a form of exteriorised thinking. The design is driven by a speculative question that positions movement as the central concern. This centrality has been unpacked in relation to the design process, to the spread of movement throughout the building, to movement's spatial relevance, and ultimately to the building's utility. Other design drivers have been of a practical nature, and were rooted in previous design experience of movable architectural structures.

Section 3.2 describes the process of design and making, revealing a number of key influences. Those influences all relate to the manifestation of movement in the prototype. The insights of this section therefore can be related to the three qualifiers of structured movement: (1) intentional, (2) realised, and (3) beyond utility. The three qualifiers will be revisited below. When applied to the prototype, they will be given further significance.

(1) Intentional movement holds a reference to the design process and its expressed design intent. Structured movement is designed to form a fundamental part of architecture. In the prototype described in this chapter, this intentionality is obvious: movement was the starting point of the design—it was implied in the question that led to the design.

The prototype developed into exhibiting two types of movement. One type is driven by external forces and is open to stochastic variation, causing the strips to wobble in a wave-like manner. The other type is determinately driven by internal forces, activating the twisting and bending behaviour that is inherent in the strips.

Both types of movement are the result of design. In an iterative process, the use of actuators, mechanism, material and dimensions was considered and refined. The movement driven from inside the prototype makes use of motors to twist the strips in a controlled manner that is entirely prescribed and predictable. The movement driven from outside makes use of airflow to actuate the strips in a manner that is less controlled, but no less precise. The length and thickness of a strip, and stiffness and direction of its supports, determine the strip's sensitivity to airflow and provide

the constraints for the movement to take place. The two types of movement interact: as the strips gain on geometric stiffness with twisting, they become less agitated by the airflow. This effect is emphasised by the changing orientation of the strips.

Intentionality refers to movement that has been deliberately designed to occur in a certain way. It does not matter whether this movement unfolds exactly as carefully choreographed in design, or if it takes place as the result of carefully set conditions. Both are manifestations of intent.

(2) Realising movement at architectural scale was the purpose of making the prototype of such dimensions that it could be entered by a person, that it could be occupied. Drawing or virtually simulating movement would not be sufficient, neither would it be sufficient to make a physical scale model.

Actual movement has persisted across the gap separating it from the ideal. As many experienced architects and engineers know, overcoming that gap is no trivial matter, and design should take this into account. Some of the aspects to consider are the imperfections present in material, the implications of manufacturing, and effects of size. But additional complexities over static architecture are presented by movement, such as the exponential increase in usage scenarios to consider, or the additional expertise required for manufacture and assembly. The criticality of maintenance is another important difference.

These aspects have played out in the prototyping process. The misalignment of the strips is one example of a problem that would have been encountered only at the prototype scale. The likely cause of the misalignment (but this remains untested), is a combination of factors. The sensitivity of the flexible strips to the orientation of both the holding plates, the unintuitive process of adjustment, the play in the rotary bearings, and some creep in the material may all contribute to this problem. But these factors became relevant only in the physical form of the prototype.

The breadboarding approach that was taken in making the prototype, served a modular approach, where components could easily be changed for testing in the prototype. The modularity was exploited in replacing several stepper motors, drive belts, and pulleys to improve drive performance. The readiness for testing and changing parts in the prototype is similar to a readiness for maintenance—it implies accessibility of the parts and a non-invasive procedure for replacement.

Realised movement has overcome the complexities of concretisation. Movement that is realised as such has been made available as a spatial phenomenon and becomes part of the built environment.

(3) Movement Beyond Utility refers to movement that does not purely serve a functional purpose. In the case of the prototype, the strategy for investigating movement was to look at it in isolation, as a form of filtering. Movement was investigated in its own

right, detached from concerns about its practical usefulness to occupants. The central role of movement in the design therefore addressed certain concerns of architecture, namely the creation of space, but not others, such as weather protection.

But for architects and engineers observing the prototype, the moving strips would immediately be assigned a potential functionality. The strips were primarily regarded as facade or roof elements, shielding the interior from an outside environment.

This shows, first of all, that it is difficult to truly detach the functional aspects when a space is considered architectural, but also that functionality might well be assigned after a component has been designed in isolation. Even though it might need adjustment, the arrangement of strips could be conceived—in some form or rearrangement—as a functional ceiling, roof, wall or facade.

Significance beyond utility is not restricted to the investigative character of movement, such as in the prototype. Other aspects— aesthetic, expressive, or traditional—will be discussed in the works presented in chapter 4. In some cases, these aspects are integrated with functionality.

Section 3.3 analyses the process of prototyping as an associated hypomnesic milieu. This analysis develops the enactive concept of exteriorisation, applied to the prototype and the process of creating it. The analysis takes place along four aspects that make up this milieu, identified as mnemotechnique, stepping stone, digitisation and communication. Mnemotechnique refers to the use of physical signs and placeholders, sometimes explicit in written form on the prototype; the prototype as stepping stone allows the creator to make the leap to the next thought, by keeping the structure in view; digitisation of the process of fabrication is a form of grammatisation that allows for the coding and decoding of a collective knowledge; and the aspect of communication positions the prototype as a shared language with a common starting point. This analysis has been undertaken first in order to describe the prototype as a tool for thinking, as set out in subsection 3.1.1, but it can also be more generally related to the process of actualising architecture. The aspect described as grammatisation of the fabrication process for example, applies equally to any process of digital fabrication.



3.54 Shigeru Ban Architects, Naked House.

We can also think of the hypomnesic milieu with regard to the practice of occupation. A building can be said to fulfil a mnemonic function, exemplified in monumental architecture that refers to a certain history, but also in implicit instructions for use, such as the position of a door, or the adjacency of rooms in a house. Typologies in architecture can be said to grammatisate architectural knowledge and use patterns—these structures can be read by an occupant. The ability to change those structures allows for a certain coding by the occupant, meaning that their own memories can be stored in the structure. Shigeru Ban's *Naked House* (2000) in Kawagoe, Japan (figure 3.54) is an example of where this applies, and where movement becomes instrumental in a hypomnesic milieu. Rooms on wheels can be positioned anywhere in a large open space,

enabling the building to store traces of use. Examples discussed in chapter 4 also allow for such coding: OMA's *Maison à Bordeaux* features a platform that can be moved between floors so that plan and routing are reconfigured, and Greg Lynn's *RV Prototype* can be rotated along two axes for use in different ways.





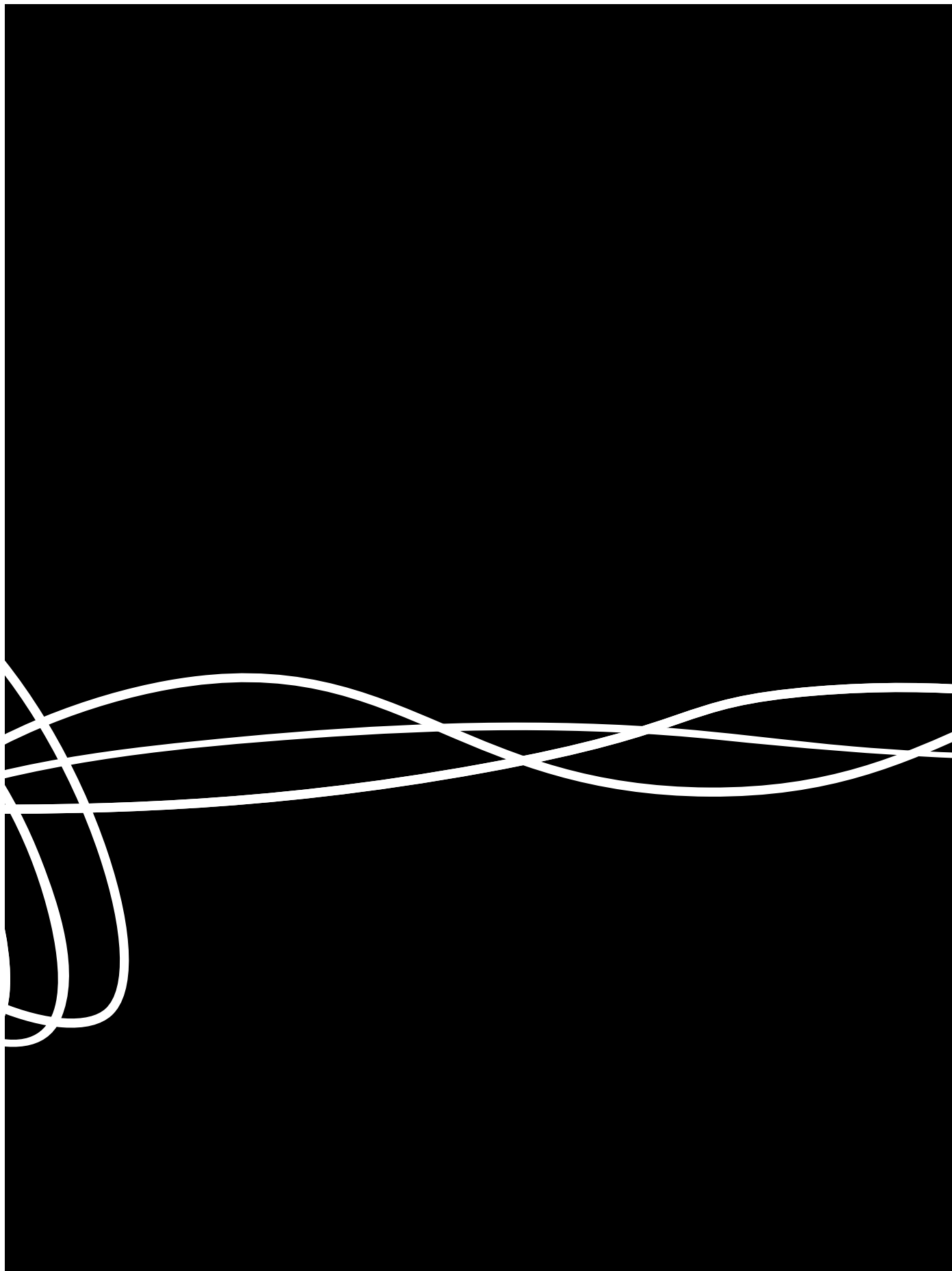

**4.**

# **Nine Works**

This chapter describes nine works of architecture and art that contribute to a view of architecture as enactive. The nine works can all be said to be characterised by movement and have been selected based on criteria that were established in chapter 2. The total of nine works was established in order to have a large enough selection to draw different relations between the works and to discover patterns, whilst at the same time being able to analyse the works both theoretically and in technical detail. The analytical descriptions contain recurring elements, but they are, just like the works themselves, not uniform. Although the investigative approach for each project has been similar, the findings along the way have led to some works receiving a more theoretical treatment whereas others are approached more practically. Similarly, in some cases there is more emphasis on context and in others, the work itself has a more central position. Recurring elements in the descriptions are the context of the work, a general description of the work (Appearance), a technically oriented description of the movement mechanism (Moving Parts), and a more subjective interpretation of the movement (Movement). Comparisons to other works, often outside the selection of the nine, are also made (Resonance). The relevance of the movement with regards to the enactive view is written in each text, and is analysed further in relation to the other works in the concluding section of this chapter.

The term *work* has been used to refer to the artistic or architectural output that is the subject of this chapter. This output covers artworks, working prototypes, temporary pavilions, and functional buildings, and is sometimes also referred to as piece, project, production, building, installation, or prototype. The term was chosen because work can be used in all these cases, and because work also expresses action.

## A Total of Nine

In one sense, the number of nine works is quite arbitrary. The number could have been seven, eight, or ten, and a similar argument could have been made in this thesis. Cecil Balmond has set out the special arithmetical and mystic properties of the number nine and found that “the number nine seems to be a point of initiation and departure, a beginning and an end” (Balmond, 1998, p. 29). Although there is no hard rule that prescribed the selection of nine works, there have been various considerations that led to this number.

First, the number had to be large enough to provide a certain diversity among the projects and at the same time allow for meaningful similarities to compare projects amongst each other. A layering of meaning could consequently be instigated that would not be binary but could offer nuance in a discussion about movement of architecture.

Second, the number had to be small enough to be practical. There is a certain appeal in the symmetry of a squared grid, and the smaller square,  $2^2$ , would only have had four grid positions, which is deemed too little to develop a nuanced position. The bigger square,  $4^2$ , has 16 positions. Describing 16 works would have been a considerable increase in effort and its analysis would not necessarily have led to deeper insight. The nine-square grid has another characteristic, which is that it cannot be equally

divided. This also adds to the idea of nuance and the avoidance of a binary position.

Third, John Hejduk developed the nine-square problem at the University of Texas and later at Cooper Union in New York. The problem is a pedagogical tool that was used to introduce architecture to new students (Love, 2003). Students were asked to design a project based on a square floor plan, subdivided in nine equal squares. Hejduk explains:

**Working within this problem the student begins to discover and understand the elements of architecture. Grid, frame, post, beam, panel, center, periphery, field, edge, line, plane, volume, extension, compression, tension, shear, etc. The student begins to probe the meaning of plan, elevation, section, and details. He learns to draw. He begins to comprehend the relationships between two-dimensional drawings, axonometric projections, and three-dimensional (model) form. The student studies and draws his scheme in plan and in axonometric, and searches out the three-dimensional implications in the model. An understanding of the elements is revealed—an idea of fabrication emerges. (Franzen & Hejduk, 1971, p. 7)**

Thus, the nine-square problem is one that helps the beginning of an understanding. Thinking about the elements that best suit each square, and drawing the structure from different viewpoints, provides the students with critical insight that is fundamental to understanding architecture. This understanding emerges not from analysing an individual square, or even from the relation between one square and another, but it appears from studying the complex of relations in the structure of the nine squares together. At that point, the relevance of what exactly is in each square is less important, as what matters is the structure of relations. The exercise enhances the capacity of the student to apply this new understanding beyond the bounds of the exercise, in order to analyse or design the next assignment.

The nine-works approach that I have followed, has a similar aim, in that it seeks to find structures that are fundamental to movement in architecture by analysing a collection of works. Parallel to the nine-square problem, this structure emerges from looking at these nine works in different ways and in portraying these views. Although the works have been carefully selected, other works could have replaced each of them, and the insights from doing this exercise may therefore also be applied more broadly to works beyond the direct focus of this research.

## Selection of Works

Nine different works could have been selected without necessarily compromising the research outcome. However, the works have been selected in line with the selection criteria for structured movement, as established in section 2.3.5. Structurised movement addresses movement that can be said to form a critical aspect

of a building in its architectural make-up. Three qualifiers prescribe structured movement in the nine works to be (1) intentional, (2) realised, and (3) beyond utility. This means first that in the case of all the nine works, movement has been specifically designed to be constitutive. Second, it means that the works are not merely design ideas, but have been tested in the physical world. And third, it means that movement is not merely utilitarian, but serves another purpose, for example by giving investigative, aesthetic, or critical meaning to the work. Within the confines of those qualifiers, a variety still exists that this thesis does not attempt to completely cover, but the selected works are varied in different ways.

Works have been selected with different dimensions, from a scale model to a multi-storey building. Similarly, works have been selected with different types of movement. Some involve the coordinated movement of a large number of actuators, others have a single moving element. Movement is translational, rotational, or chaotic. Movement is fast or slow. Movement is discrete or continuous. And movement is controlled or emergent. In some works, movement is present in the envelope, in some inside the building, and in others the whole building moves. Some movement is motorised, other movement is induced by forces of nature. Some works are icons and well described, others are relatively obscure.

However, all works are relatively recent, with the oldest dating back to 1959. There are relevant artworks and architectural projects that predate that year—some are used as references in the text—but with the rise of kinetic art in the 1950s and with kinetic architecture following soon after, a discourse developed that is generally richer than the period up to the second half of the twentieth century. The theoretical basis for this research is also rooted in approximately the same timeframe.

In dealing with movement, the works in focus are sometimes unique in the practice of the designers that conceived of them, and sometimes part of a larger body or a series of works. It should also be acknowledged at this point that most of the works have been created as efforts involving more than one person. Nevertheless, the authorship is often generally attributed to a single person or organisation. This thesis will mostly follow those general attributions, but where relevant, will address specific contributions by others.

The chronological indication is the year of completion. In two cases, the works are actually a series of works, and the date of the primary piece is used.

Section 4.1 describes *329 prepared dc-motors, cotton balls, toluene tank* by Zimoun (2013), Dottikon, Switzerland. The work is an art installation of architectural scale that involves a large amount of independently moving actuators. This work was visited in March 2017. It was further analysed from photos, video, and an interview with the artist.

Section 4.2 describes *Aegis Hyposurface* by Mark Goulthorpe (2001), a temporary installation that has been exhibited in a reduced format at the Venice biennale in 2000, and in 2001 in a large setup at the CeBIT fair in Hannover. This work has been analysed from architectural descriptions, technical papers, photos, and video.

Section 4.3 describes the *Wacoal-Riccar Pavilion* by Ren Suzuki and Shota Majima (1970), Osaka, Japan, now demolished. The work was part of the Expo in Osaka and featured a large circular roof that was moved by the wind. This work has been analysed from architectural drawings, architectural descriptions, technical papers, photos, and video.

Section 4.4 describes *Maison à Bordeaux* by OMA (1998), Floirac, France. The work is a villa with a central moving platform. The building is listed as a historic monument. This work has been analysed from architectural descriptions, engineering drawings, photos, video, and an interview with a partner in OMA.

Section 4.5 describes *Blur Building* by Diller + Scofidio (2002), Yverdon-les-Bains, Switzerland, now demolished. The pavilion was part of the sixth Swiss national exposition that took place across four locations at the foot of the Jura mountain range. This work has been analysed from architectural descriptions, architectural drawings, photos, and video.

Section 4.6 describes the *Southern Facade of the Institut du Monde Arabe* by Jean Nouvel and Architecture Studio (1987), Paris, France. The Institut du Monde Arabe (IMA) is a cultural centre in central Paris. This work was visited in September 2016. It has further been analysed from architectural descriptions, architectural drawings, technical reports, photos, and video.

Section 4.7 describes *Spazio elastico* by Gianni Colombo (1959), a temporary installation recently on display in various exhibitions triggered by a renewed interest in kinetic art. This work was visited in April 2016. It has further been analysed from descriptions, photos, and technical drawings.

Section 4.8 describes *RV (Room Vehicle) House Prototype* by Greg Lynn (2012), a temporary installation. The work is a scaled down prototype that was commissioned by the Biennale Interieur as part of the Future Primitives programme. A smaller scale model of this work has been observed in March 2017. It has further been analysed from descriptions, photos, and video.

Section 4.9 describes *Envir(On)ment* by Hugo Mulder (2017), a temporary installation. The work was produced as a research prototype, supporting the main investigation of this thesis. This work has been analysed throughout its design and production process, which were conducted by the author. Photos and video have aided in recalling aspects of the work.





## 4.1 329 prepared dc-motors, cotton balls, toluene tank (2013)

*329 prepared dc-motors, cotton balls, toluene tank* (2013) is a work of art conceived by Zimoun, an artist based in Bern, Switzerland. The work is located in Dottikon, which is a small municipality in Switzerland, located approximately 30 km west of Zürich. Dottikon is also the name of the chemical plant that has been located there since 1913. Initially, the plant made explosives and has since specialised in unstable chemical processes, for the production of ingredients in medicine, for example. The artwork was commissioned for the plant's centenary in 2003. For brevity, it will be referred to here as *Dottikon*.

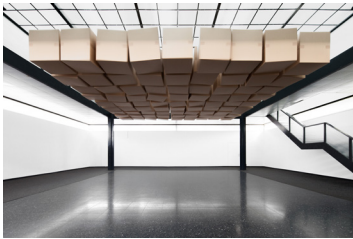

4.2 Zimoun in collaboration with Architect Hannes Zweifel, 20 prepared dc-motors, 81 cardboard boxes 70x70x70cm.



4.3 Zimoun, 36 ventilators, 4.7m<sup>3</sup> packing chips.

Zimoun's work often combines sound and sculpture in a way that does not prefer one over the other. If there would be a preference, he explains in an interview, he would then try to reduce the work to that aspect. The works are installations, or *compositions* in his own words. In many cases, his works can be regarded as architectural, due to their form, size or location. For instance, the works take the shape of building elements such as ceilings or walls (figure 4.2), or form entire enclosed spaces that visitors can enter. Some works transform existing spaces by taking up large areas of floor or wall space, or by being featured in highly visible places (figure 4.3).

*Dottikon* is a project that works at architectural scale. An old steel storage tank for the industrial feedstock toluene has been coated white inside and is lit with bright, white light—its cylindrical wall covered with small wobbling dots, restlessly bouncing on the wall. This is not an intervention in existing space, but the tank is part of the installation. The work is aptly nicknamed the *Klangtank*.

In one way, this work is representative of the artist's work, and in another it is unique. Most works that were produced after 2003 feature large amounts of simple machines that repeatedly perform a single action. The acoustic aspect of the work emerges from the contact sound generated as the machines interact with their environment. *Dottikon* also consists of a large amount of such machines. The project's uniqueness lies in it being a permanent installation, which has been designed for longevity and maintenance. The long design life of the work presented different challenges to Zimoun and his team. He explains:

**It was the first permanent piece I did, and it is to date the largest. Permanence poses a difference. For instance here, at Godsbanen in Aarhus [28 February 2017], we are happy if the installation runs for a month, but the permanent work in Dottikon should still run in 100 years. We were challenged with questions about what this means. The tank in Dottikon for example has a thin wall of 8-12 mm, even if its total weight is about 30 tons. The temperature in summer can reach 80 or 90 degrees in the top, and if it is a cold winter it can get as low as -20. This gives a temperature range of more than 100**

4.1 329 prepared dc-motors, cotton balls, toluene tank. The work is a permanent installation in a disused industrial storage tank.

degrees, with implications for the material, the wiring, etc. The thermal expansion causes the wires between motors to loosen or tighten. And if it cools down fast, humidity builds up inside. (Zimoun, personal communication, February 2017 and April 2018)

## Appearance

Dottikon is an industrial cylindrical liquid storage tank from 1951 that was used to store toluene. The tank is 9.4 m in diameter and 12.8 m tall. The tank has been given a new location, just on the other side of the plant it was part of, and now stands on a small plot by itself. A new concrete foundation has been constructed for that purpose along with a path for visitors. An entrance door was added at the bottom of the tank.

The tank has been prepared inside by welding small extension rods to the cylindrical wall. The rods are placed along eleven horizontal hoops, 30 rods in each hoop, and 29 in the bottom hoop that has one rod missing at the door location. The rods are evenly spaced along the hoop, each vertical neighbour shifted half a spacing, so that the rods form a diamond pattern.

At the end of each extension rod a DC motor is mounted, the shaft fitted with a length of metal wire like a tail with a stiff cotton ball at the end. The system is tuned such that once the motor is powered, the cotton ball at the end of the tail bounces back and forth in a slightly erratic manner. The installation is powered through two parallel cables in each hoop that connect the motors. The cables are kept in tension by a spring where the cable penetrates the wall.

The walls and rods are coated white, creating a stark contrast with the largely untouched and weather worn tank exterior.

## Moving Parts

Upon approaching the tank, it seems unassuming, weathered, and the number 24 on top as if part of a larger array. However, the door at the base suggests a new life for this tank, as the paint on the door seems fresher than that on the wall around it.

When I visited the project in March 2017, the door was opened for me and light entered the dark space. I had seen the work on video, but as I stepped in, slightly hunched because of the low door, I realised the work had to be turned on with a switch beside the door. The light was controlled using a special remote control, which seemed bulky and crudely out of place, probably because of its Ex-rating, a stamp of approval for electronics in areas with a high risk of explosion.

At first, the space seemed smaller than expected, but over time

it appeared to expand, both in diameter and height. Even before being switched on, the piece seemed impressive. A large array of small black balls suspended from as many DC motors, organised in a stern and meticulous diamond grid. The combination of the industrial dimensions of the tank, with the watchmakers' detailing of the small machines was imposing, and testified to a significant technical achievement.

Once inside the tank, I noticed that the tails have varying lengths, something I had not observed before on the available photo and video documentation.

The lighting could be switched to different settings that gave more or less depth to the tank. Rings of light, recessed in the ridges of the tank, accentuated the height and the circumference.

As the work was switched on, it was immediate. Somehow, for a work this size, I had expected a slow start, but of course, nothing in the mechanism has high inertia. When turned off, the sound would slowly decay, at least in experience, and it took time for the silence to reoccupy the space.

While the work was on, movement was everywhere. Wherever I looked, I saw black balls bouncing back and forth in a pulsating rhythm. The varying lengths of the tails caused the balls to bounce differently and layers of movement emerged from the complexity as I stood trying to take in the whole picture. It felt peaceful as seemingly natural ripples occurred in the infinite cylindrical field and when I looked up, several rings seemed to appear, rotating in opposite directions. All the while, a rain-like sound dominated the acoustics of the space.

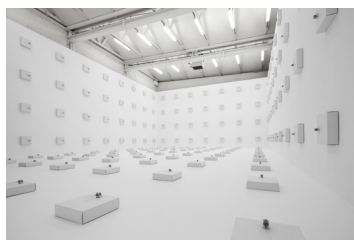

4.4 Zimoun, 198 prepared dc-motors, wire isolated, cardboard boxes 30x30x8cm.

**When do we start to feel something is complex? What is it? Is it just too much information to process? For instance, there is a piece with white boxes, positioned on the floor and on the walls, in a white room (198 prepared dc-motors, wire isolated, cardboard boxes 30 × 30 × 8 cm (2012) [figure 4.4]). A single motor on each box is just hitting it with a piece of cable. This behaviour is not particularly interesting—the sound is a regular beat. But once the room is filled with many of these boxes and when you move through the space, it becomes complex and rich. As soon as there are two, three, four, five or more of these mechanisms at work, various sound structures evolve. As in minimal music, the piece as a whole generates micro-rhythms, patterns, and always changing structures. It is a complexity that emerges from a simple *tak tak tak*. (Zimoun, personal communication, February 2017 and April 2018)**

## Movement

The movement of the installation can be described on different levels. Each machine moves in a particular way. The motor axis rotates at constant speed, turning a flexible metal wire with some mass in the form of a cotton ball towards the end. The metal wire connects a constant supply of kinetic energy to a ball that releases this energy in bursts, and as a result, strikes the wall of the tank erratically. The rhythm of the movement seems somehow natural, though, as if something is flapping in the wind. While each machine moves in its particular way, the scene as a whole unfolds as if a swarm of machines is at work. It seems impossible to point to the centre of this swarm, as the circularity of the wall provides infinity. Above all, the cumulative effect of all these machines is that the whole tank seems to be in motion. A gentle bob that cannot be attributed to any of the machines has emerged as a form of meta movement at the architectural scale of the tank, a magnitude higher than the movement each of the machines produce.

From this perspective, the work can be said to be generative. A certain coherence emerges from the individual and disconnected small movements. Accustomed to recognising patterns, we see waves travel across the field of movement and we hear the sound of rain. As an observer, however, it is impossible to judge whether these waves are actually occurring, or if the mind is filling in the gaps. The installation does not work as a swarm, as there is no mechanism that couples the entities and that would allow for a change in their performance. Rather the individual movements are autonomous and constant, and constitute a complex field of

4.5 Ned Kahn, Project Lions. The work covers the facades of the Debenhams department store on Oxford Street in London. Detail of the facade.

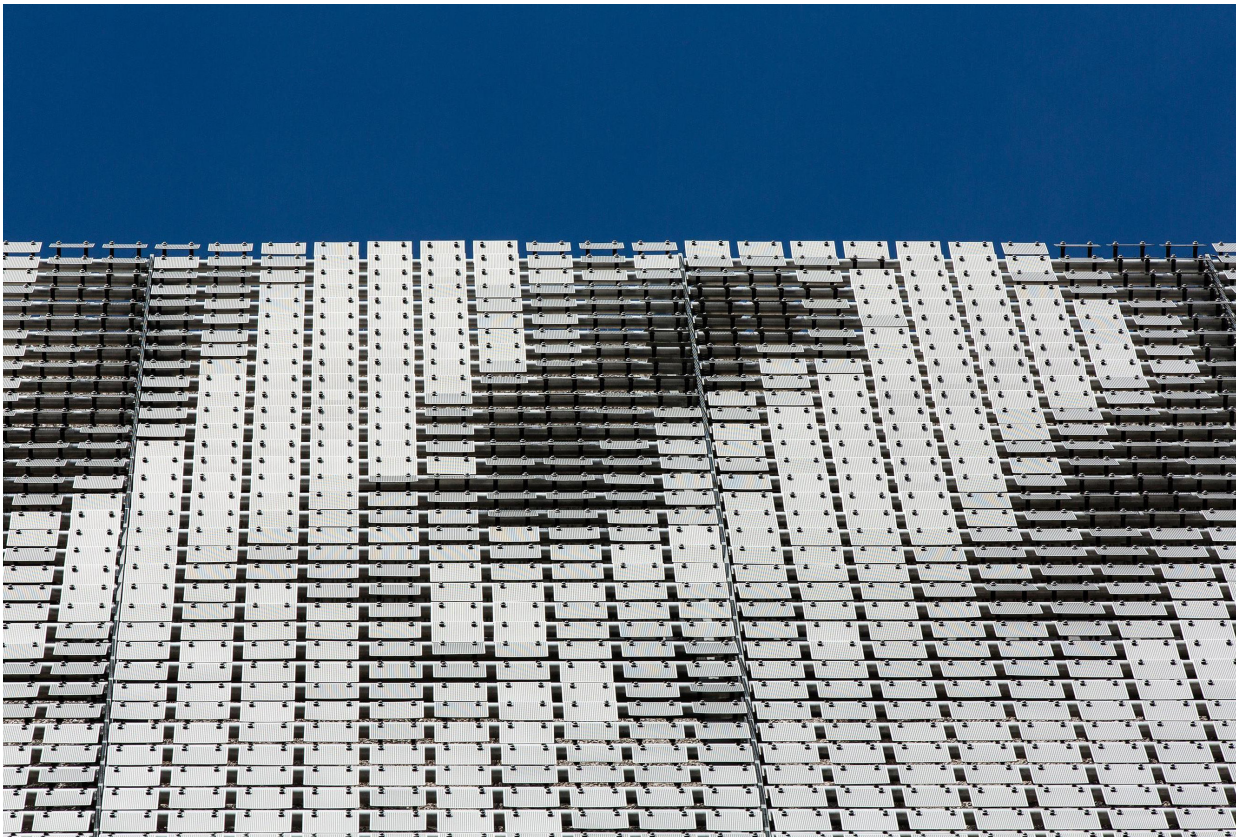

unstructured movement. This differentiates the work from a piece by Ned Kahn, such as *Project Lions* (2014), which involved wrapping the Debenham's store on Oxford Street in London (figure 4.5). Like many of Kahn's other works, the piece deals with complexity and is, like much of Zimoun's work, also made up of large numbers of simple mechanisms. Here, however, the movements are driven by the wind—complex nevertheless, but a coherent external force. This means that Kahn's works visualise the complexity of something external, whereas Zimoun's work gives rise to a complexity that comes from within.



**4.6** Alexander Calder, *Black Widow*. The mobile was donated to the Brazilian Institute of Architects in São Paulo.

Visual and structural dissimilarities notwithstanding, a parallel can be drawn to a mobile by Alexander Calder that was donated by him to the Instituto dos Arquitetos do Brasil (the Brazilian Institute of Architects). The mobile, entitled *Black Widow*, hangs in the lobby of the institute's local headquarters at the corner of Bento Freitas and General Jardim streets in São Paulo (figure 4.6). The building was designed by a team that included amongst others, friends of Calder: Rino Levi and Jacob Ruchti. The lobby, a double-height space flanked by a mezzanine, features the 3.5-m hanging mobile suspended from the ceiling. Visible from outside the building, the mobile draws attention into the interior, modulates the incoming daylight, and its kinetics create a sense of weightlessness as a counterpoint to the gravity of the architectural mass (Martins, 2016). Not just as an object, but through its movement, filling the space, the mobile connects the levels in a way that is described by the Brazilian architect Henrique Mindlin as a “*conexão psicológica*”, a psychological connection (Calder & Saraiva, 2006, p. 88).

This relation of the piece to the space it occupies shares similarities with the work of Zimoun in that the movement of the art fundamentally touches on how the space is read. Perceiving and understanding the movement of the piece makes us perceive the whole space in a particular way. This is the connection between floors that Mindlin described, but it is also the altered sense of spatiality in *Dottikon*; the effect of which can be clearly experienced after the work is turned on or off.

The *conexão psicológica* that was attributed to Calder's mobile in Brazil suggests a coupling between the occupant and the building that is brought about by the motion of the mobile. This coupling is enabled by a particular sensitivity to movement of the environment on the part of the occupant, the environment being the architectural space including the mobile. The experience in *Dottikon* of an overall movement of the space is due to the subjective perception of the individual movements of the black balls combined. It arises in the particular way that my physiology and history allows me to perceive this phenomenon. Because there is no visual or auditory connection with the world outside, *Dottikon* clearly demonstrates the coupling between the occupant and the building. Other examples will show how this coupling can be extended to the larger environment.



4.7 329 prepared dc-motors, cotton balls, toluene tank. Inside, looking along the wall. Rings of actuators are visible along with the variation in tail lengths.



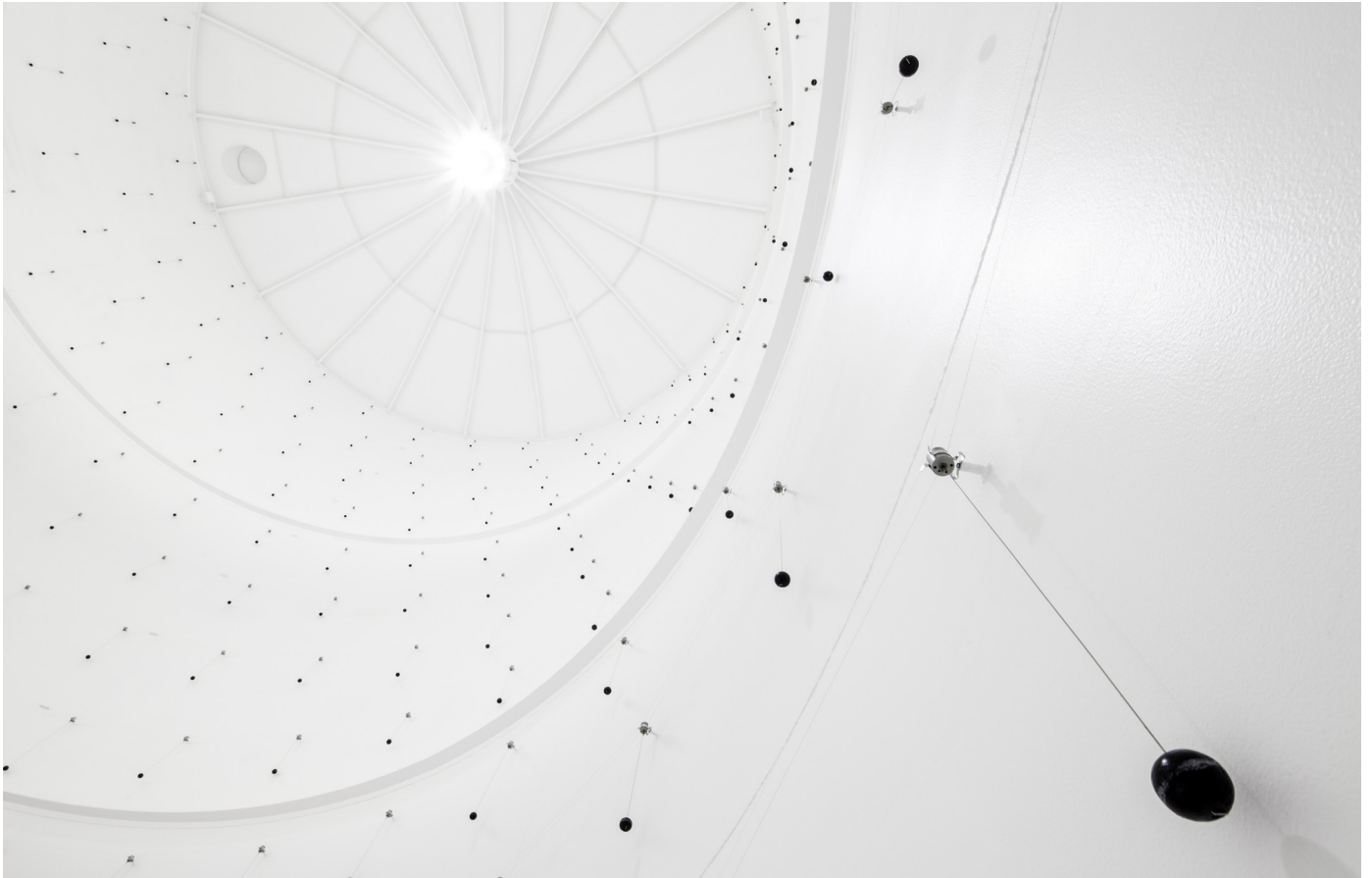

**4.8** 329 prepared dc-motors, cotton balls, toluene tank. Inside, looking up. A single actuator is visible in detail, as well as the pattern of actuators mounted on the wall.

**4.9** 329 prepared dc-motors, cotton balls, toluene tank. The tank in the context of the active industrial plant. The number 24 is clearly visible.

**4.10** 329 prepared dc-motors, cotton balls, toluene tank. Outside. The door hints at changes made to the tank.





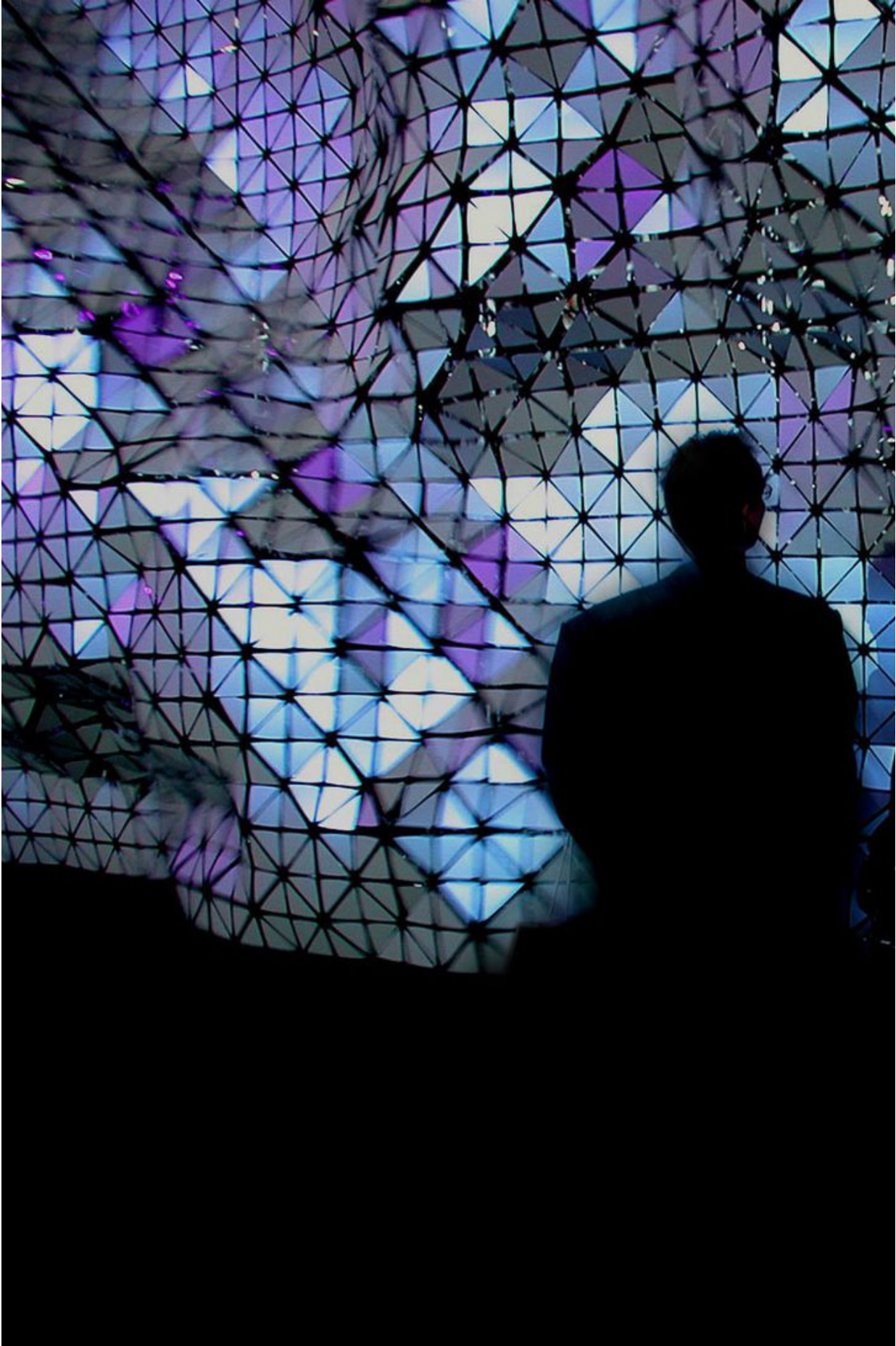

## 4.2 Aegis Hyposurface (2001)

In 1998 and 1999 Stephen Perrella set out his theory of *Hypersurface* in two introductions and as editor of two editions of *Architectural Design (AD): Hypersurface Architecture* (Perrella, 1998; 1999). This was not the first time this theory was published, but it became specific in a context of architectural proposals, some highly speculative and manifested in evocative renderings, and others realised as buildings. Perrella's theory sought to philosophically underpin the confluence of two tendencies that became increasingly prominent at the time.

On the one hand, there was the proliferation of media: the abundance of visual images, the commercial world of advertising and the rise of the internet (cyberspace). Perrella sketches a human condition that is *techno-existential* and places humans in a relation to media that is inescapable. On the other hand, a new architectural language emerged in the work of, for example, Peter Eisenman, Greg Lynn, Frank Gehry and Ben van Berkel, which we may now refer to as the topological movement. Influenced by Deleuze and facilitated by computer aided design and animation software, these architects sought to create form that expressed a dynamic plasticity in continuous surfaces that would curve organically.

Perrella discusses hypersurface as an *interface* between subjectivity and materiality that works from “the middle-out”, where the one

4.12 Diller + Scofidio, Jump Cuts.



would naturally inform the other. The theory does not seek to fuse the two, “but allows for both simultaneously” (Perrella, 1998, p. 12):

**The co-presence of embodied experience superposed upon mediated subjectivity is a hypersurface. The manifestation of this construct in the built environment is a reflection of this. [...] Hypersurfaces appear in architecture where the co-presence of both material and image upon an architectural surface/membrane/substrate [exist] such that neither the materiality nor the image dominates the problematic. (p. 13)**



4.13 NOX, HtwoOexpo. Fresh water pavilion.

The publications illustrate the relevance of the theory in the cultural movements at the time. Apart from Perrella’s own speculative work, the two publications feature early work from Asymptote, Reiser + Umemoto, and a cinema facade by Diller + Scofidio with Paul Lewis (figure 4.12) that was “flipping the building inside-out electronically” (Perrella, 1999, p. 77). Of the realised buildings that were featured, arguably the works of Lars Spuybroek and Kas Oosterhuis on the artificial island of Neeltje Jans in the Netherlands dealt most literally with the superposition of media onto topological surfaces. In Spuybroek’s fresh water pavilion *HtwoOexpo* (1997), shown in figure 4.13, and Oosterhuis’ *Salt Water Pavilion* (1997), in figure 4.14, floors and walls have become indistinguishable, creating interiors that include water, ice and mist, and electronic media such as interactive sound, light and projections. Lars Spuybroek writes:

**Why still speak of the real and the virtual, the material and the immaterial? Here, these categories are not in opposition or in some metaphysical disagreement, but more in an electroliquid aggregation, enforcing each other, as in a two-part adhesive; constantly exposing its metastability to induce animation. (Perrella, 1998, p. 51)**

In the second publication, Mark Goulthorpe introduces the *Aegis* project (Goulthorpe, 1999). Goulthorpe discusses *Aegis* not as *hypersurface*, but as *hyposurface*; deliberately shifting from an expressive state to one that is subliminal and subjected to external forces, *alloplastically* informed and formed by the world around it, “alloplastic as a reciprocal environmental modification” (Perrella, 1999, p. 63).

Inspired by William Forsythe’s rule-based and emergent choreographies, Goulthorpe discusses *HypoSurface* in the light of what he calls “precise indeterminacy” and lack of a grand perceptual and representational framework that forces a continuous dis- and re-orientation. He later says:

**First and foremost, [Forsythe’s] Frankfurt Ballet was an exercise in a shifting choreographic praxis—that’s what he was experimenting with. Only by changing his creative praxis could he change the relationship between audience and ballet. He was thinking very hard about the manner of his choreographic method at that time. (Lynn & Goulthorpe, 2014)**

Forsythe’s suggestion for his ideal theatre as an “indeterminate space”, a space that would force his dancers to constantly

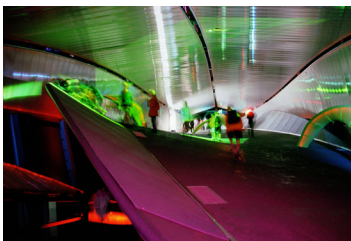

4.14 ONL, Salt Water Pavilion.

recalibrate their movements, was a trigger for Goulthorpe to make an architecture that could actually move (Lynn & Goulthorpe, 2014).

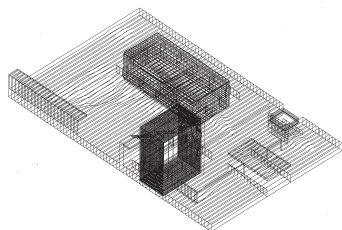

4.15 dECOi, Prothesite.

## Appearance

The *Aegis* project started as a competition entry for a public artwork in the Birmingham Hippodrome theatre that was undergoing refurbishment by Associate Architects of Birmingham and LDN architects from 1999 to 2001. The competition called for an artwork in the facade that would somehow reveal on the outside what happened inside the theatre. dECOi architects had won a first prize in 1995 for a speculative project at the Nara/Toto World Architecture Triennale in Tokyo, called *Prothesite* (figure 4.15). This project was envisaged as a “platform [...] into which abstract architectural elements are plugged”. Its surfaces were continuous, the line drawings suggested a lofted landscape with discrete cartesian forms superimposed on it:

**[S]mall pulses of energy seem continually to be flickering across them, a sort of dynamic single-state surface, continually reconfiguring or recalibrating itself in response to contextual stimuli: an evidently interactive architecture. (Toy, 1996, p. 25)**

4.16 Aegis Hyposurface. Design drawing.

Where *Prothesite* remained a design proposal, *Aegis* materialised as a working physical prototype in various forms from 1999

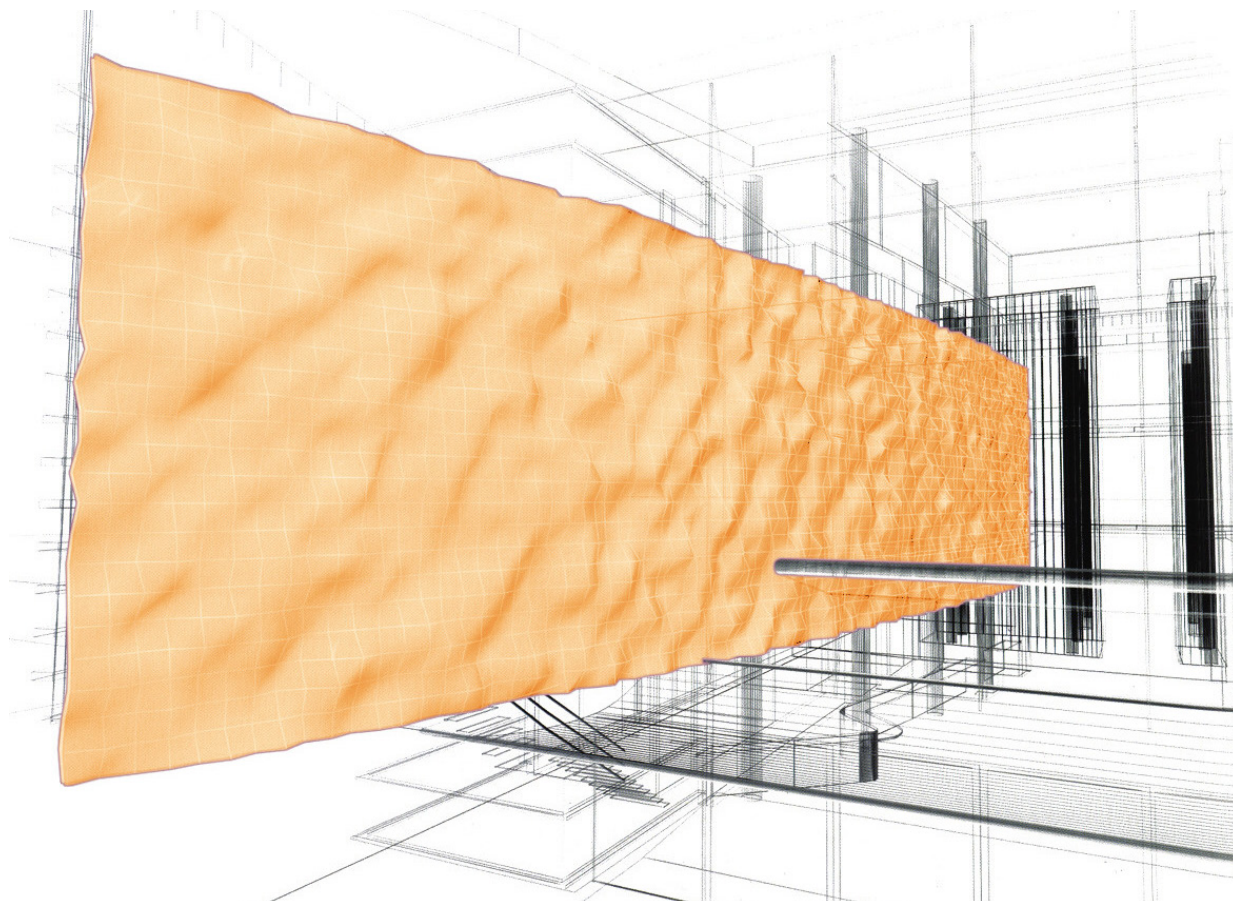

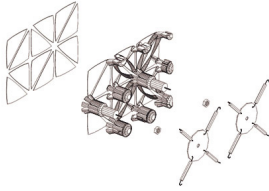

4.17 Aegis Hyposurface. Assembly drawing showing squids.

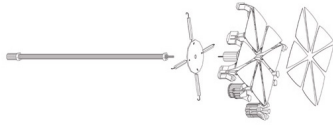

4.18 Aegis Hyposurface. Assembly drawing showing piston.

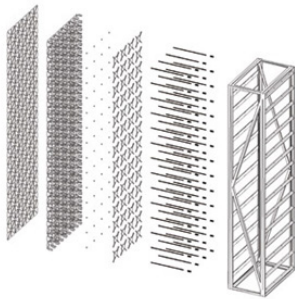

4.19 Aegis Hyposurface. Assembly drawing of a unit frame.

onwards. Its development was the result of a collaboration between experts in parametric modelling, mathematics, electrical engineering, computer control, pneumatic actuation, material science and structural engineering (Goulthorpe, Burry, & Dunlop, 2001). *Aegis* is a dynamic surface that can display dynamic generative patterns, as well as text and images in relief. Sensors would further allow it to be responsive to people near the surface. Various versions with different dimensions have been developed, and to a certain extent, its development is still ongoing (Lynn & Goulthorpe, 2014). In 2000, a version measuring  $1 \times 3.5$  m with 56 actuators was exhibited at the Venice architecture biennale. In 2001, a much larger version measuring  $3.5 \times 10$  m with 576 actuators was displayed at the CeBIT computer conference in Hannover, Germany.

## Moving Parts

The whole system is a box-frame structure that holds the actuators in a grid (figure 4.19). The dynamic surface is present on one side of the box frame, the other side is accessible for installation and maintenance. The surface is tessellated with triangular pieces of sheet metal. The edges of the triangles are slightly rounded, bulging outwards, the corners of the triangles held in rubber connector *squids* (figure 4.17). The squids allow the pieces to rotate relative to each other, but maintain positional continuity in the nodes and therefore continuity of the surface.

The alternating orientation of the triangles leads to nodes joining eight triangle vertices and others joining four. The eight-vertex nodes are actuated out of plane by pneumatic pistons, positioned in a grid of  $250 \times 250$  mm resolution and capable of rotation about their base point in order to allow the surface to stretch in all directions (figure 4.18). The piston stroke is 500 mm, providing considerable depth to the dynamic patterns. In action, the surface produces kinetic content by coordinating the linear actuation of the pistons. The control system allows for various modes of operation of the surface. One mode provides real-time manual operation through a computer interface, another mode displays mathematically derived patterns and a third mode converts visual information from a camera into a 3D image.

## Movement

From video (HypoSurface Corp, 2008; Lynn & Goulthorpe, 2014) it seems that there is quite a difference between experiencing the smaller piece that was displayed in Venice and the larger prototype in Hannover. The Venice piece was displayed as a work of art, hanging on the wall like a painting without a frame—its movements intriguing, like a work of kinetic art, such as *Strutturazione Pulsante* by Gianni Colombo (1959). The exposed edges are clean cut, cropping the endless motion patterns into a rectangle, and providing a glimpse inside the mechanism. The movement is

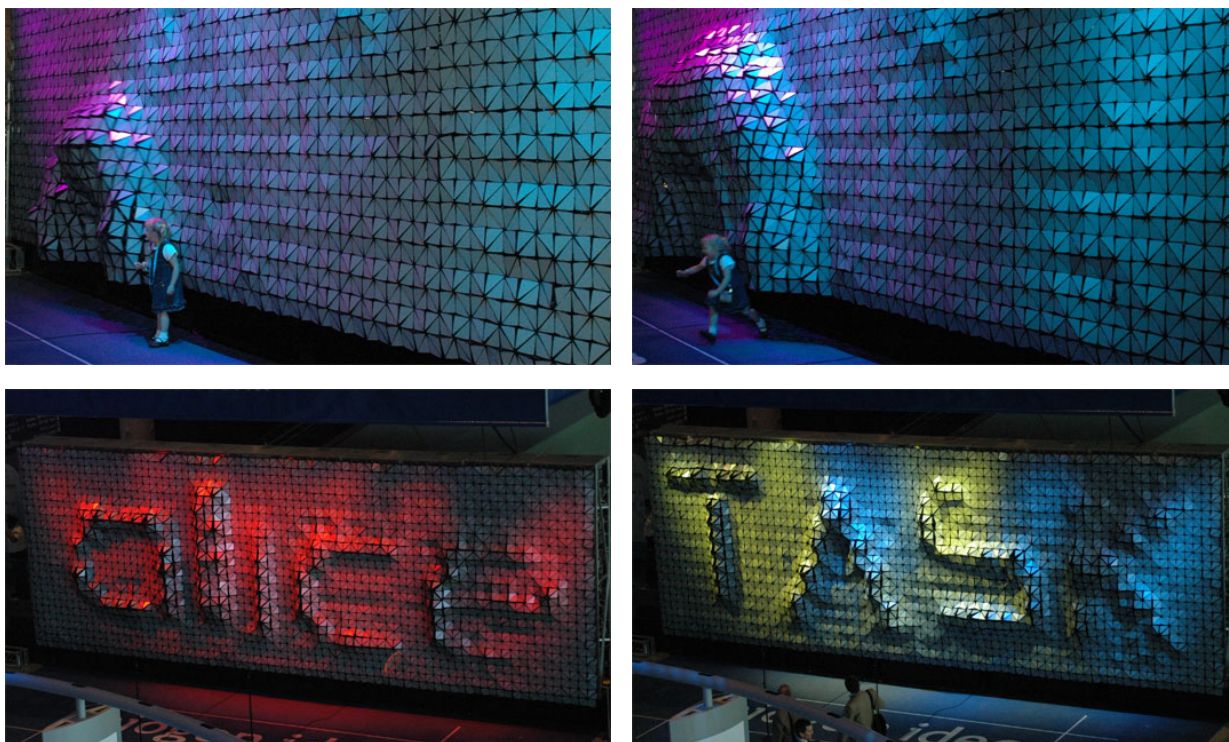

4.20 Aegis Hyposurface. Responsive mode and text mode.

supple, always a dynamic pattern, a ripple of reflections on the metal and a rubbery response to every actuator impulse. A metallic impact sound grows louder with increased excitement. The large prototype in Hannover (figures 4.20 and 4.27) is a wall and seems less precise as little glitches occur from out of sync actuators. From nearby, it seems overwhelming in size, immersive. In fact, people can be seen leaning into the wall to be physically pushed away when a wave rolls by. The wall also shows text as is common with LED walls. The delicacy of the mechanism and the aesthetic appeal of the dynamic patterns in Venice seem here to be replaced with an abundance of possibilities and use as an interactive entertainment device, which Greg Lynn has called “frighteningly dynamic” (Lynn & Goulthorpe, 2014).

There may indeed be something uncanny about the combination of size, resolution and the wild movements we see in the videos. The movements of the wall appear to be pre-programmed content, especially when we see numbers and text appear. As such, it is difficult to maintain the wall as alloplastic, rather it would be expressive of media as a *hypersurface*. Where the pavilions by Oosterhuis and Spuybroek were perhaps the perfect illustration of Perrella’s thesis of the meeting of media and surface, *Hyposurface* could be seen as a step beyond what Perrella envisaged. Not only do media and surface share the same substrate, the surface generates and *enacts* the media. The surface demonstrates its underlying (topological) logic while animating its (media) content. The interface may not have disappeared, but at least in its manifestation, media and matter have become one.







4.22 Barkow Leibinger, Kinetik Wall.



4.23 Ruairi Glynn, Reciprocal Space.

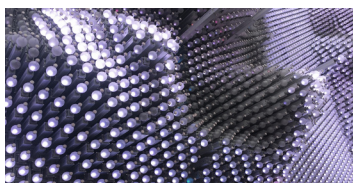

4.24 Asif Khan, MegaFaces.

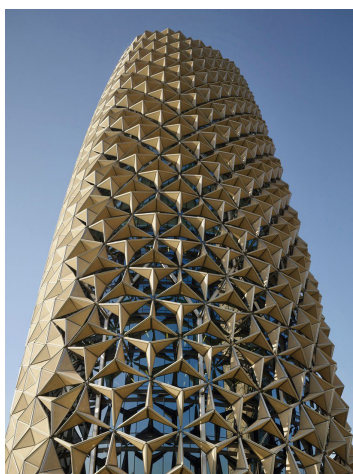

4.25 Aedas, Al-Bahr Towers.

4.21 Aegis Hyposurface. Single unit frame on display at O.K Center for Contemporary Art in Linz.

## Resonance

In a number of ways, *Aegis* has seen many successors and adaptations. A project that can almost be regarded as a tribute to *Aegis* is *Kinetik Wall* (2014) of Barkow Leibinger that was presented 14 years later at the Venice Biennale curated by Rem Koolhaas (figure 4.22). A space-frame structure holding a grid of linear actuators that dynamically manipulate a surface. The materialisation and the sense of movement are distinctly different in using timber, a stretching fabric surface, and slow movements, rendering it much closer to Ruairi Glynn's *Reciprocal Space* (2005) (figure 4.23). The idea of a three-dimensional display facade has been furthered by Asif Khan for the *MegaFaces* pavilion at the winter Olympics in Sochi in 2014 (figure 4.24). This installation uses linear actuators at a closer spacing, but omits a physical surface that connects the ends. Instead, the tip of each actuator is a multi-colour pixel that allows the work to be read from a distance as a continuous surface.

The *Al-Bahr Towers* by Aedas (2013) in the United Arab Emirates, which headquarter the Abu Dhabi Investment Council, feature an external facade surface that is also accentuated through actuators normal to its surface (figure 4.25). Physical continuity exists within in each triangular unit consisting of six triangular panels connected with hinges. Gaps appear along the sides of the larger triangle when the units are folding from a flat to an accentuated state, effectively allowing the outer facade to open and close. The facade is not designed as a display, rather it tracks the sun to control direct light entering the building.

It is worth noting that the system of an orthogonal grid with actuators normal to the surface faces the problem that the distance between the endpoints of the actuators will vary in different configurations. The four projects (*Aegis*, *Kinetik Wall*, *MegaFaces*, *Al-Bahr*) all have different strategies for dealing with this phenomenon. In order, the surfaces are either continuous and allow the actuators or the surface to deal with this in-plane deformation, or the surfaces are discontinuous and exist of free-moving pixels or discrete patches of surface with gaps in between.

## Representation

Although Perrella's language is difficult to interpret—it is larded with philosophically loaded terms and it seems to prefer ambiguity over specificity—the few available texts set out to create an abstract philosophical concept and a concrete manifestation of that concept in architecture. The abstract concept seeks to bring together physical materiality and subjective experience in a *surface* or *interface*. This surface, hypersurface, exists in the mutual relations between the material and the subjective. It is, Perrella proposes, an interface between thought and matter. Perrella also describes the hypersurface as a superposition of embodied experience and mediated subjectivity, terms that in themselves already suggest bringing together material and subjective realities.



4.26 Aegis Hyposurface. View from just below the surface, showing squids and pistons.

4.27 Aegis Hyposurface. On display at CeBIT in Hannover.

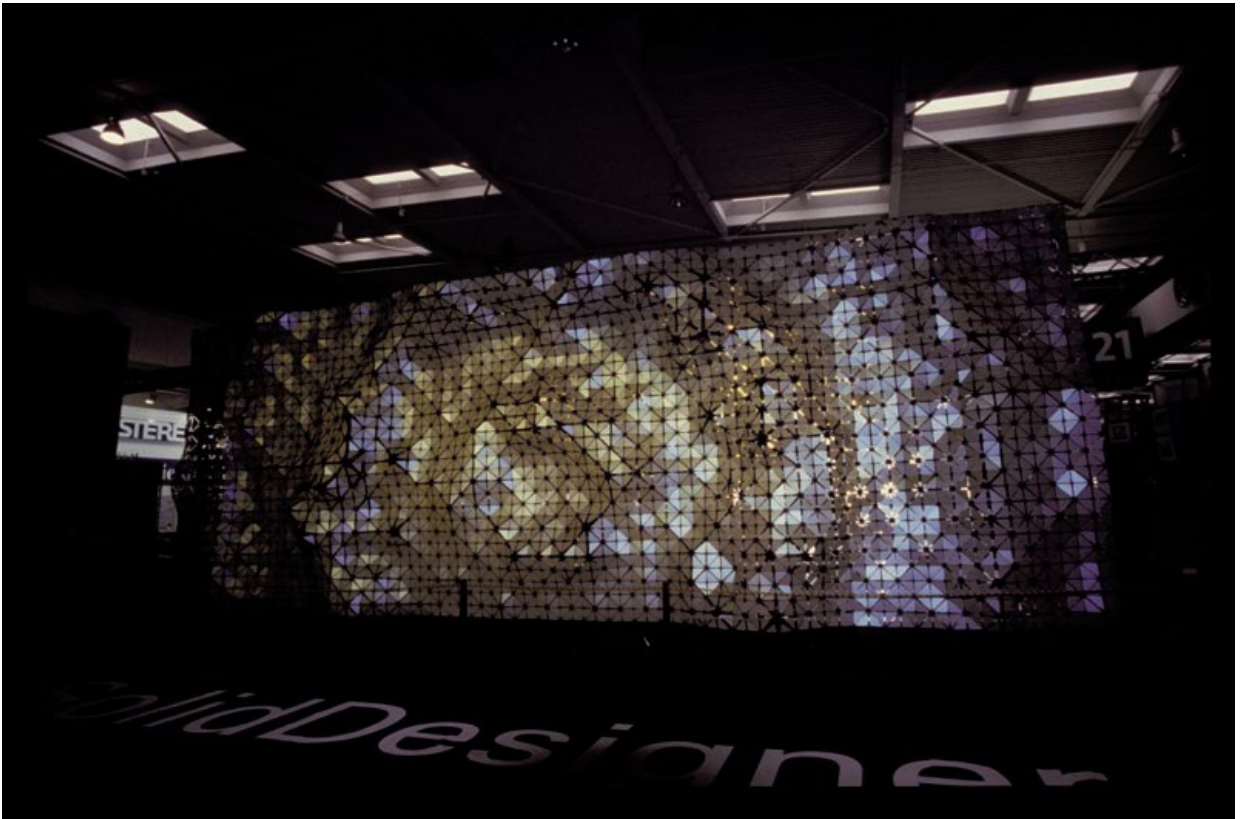

Through Perrella's curation and his own design work, the concrete manifestation of hypersurface is exemplified by architecture that seems influenced by Deleuze's thinking about *folding* and *continuity*, promoted by architects such as Bernard Cache and Greg Lynn. But rather than merely static form, hypersurface architecture consists of a superposition of form and image; the image as an exemplar of media, suggested by Perrella to be an existential part of us. The projected image, the screen, or the media-facade form part of an architecture where symbol and material are unified. This unification finds its incarnation in *Hyposurface*, where symbol and material become inseparable in a dynamic relief.

*Hyposurface* not only superposes media on its physical form, it embodies the media. Where the pavilions of Spuybroek and Oosterhuis (mentioned earlier in this section) settle for a projected image on their static surfaces, *Hyposurface* removes that layering by directly enacting the content in forming itself towards it. This content may be text or pre-produced dynamic patterns, but also the structure's own responsive state that acts on visual input.

Where Perrella discusses the hypersurface as working from the *middle-out*, avoiding the binary oppositions of subjectivity and materiality, Varela et al. discuss enactive cognition as the *middle way* between idealism and realism. Both views seem to aim at bringing together a world that is brought forth in a specific, personal manner and a world that exists out there—and both are reciprocally affected.

If we consider Goulthorpe's *Hyposurface* as the ultimate manifestation of Perrella's hypersurface theory, we can see how it treads the middle way. As a kinetic structure that is specifically designed to be sensitive to its environment, it transforms itself in response to it, rather than through a representation such as a projected image. Although symbolic representations still play a role in the computing that controls the work, on the level of the spatial manifestation, there is no difference between what the work shows us and what it is. That directness is exactly the point of Perrella when he discusses the superposition of media and surface, and it is exactly the point of enactivists claiming there is no need for mental representations: the body, in its own particular fashion, responds directly to environmental conditions.

If we refer to Bernard Stiegler, we might see that Perrella's inclusive understanding of media—he refers widely to all cultural modes of representation that are made possible by technology—is both dissociated and associated. It includes aspects of mass media produced without us, and aspects of digital culture that are produced by us. Perrella laments the role that hypersurface architecture might play in changing the possibilities for thought, but Stiegler would claim that any architecture, as being technological, would do this. Stiegler presents the same digital developments that Perrella refers to as reassuring, however, in that they hold the promise for association, which is a more direct way of coding and decoding our memory through technology.

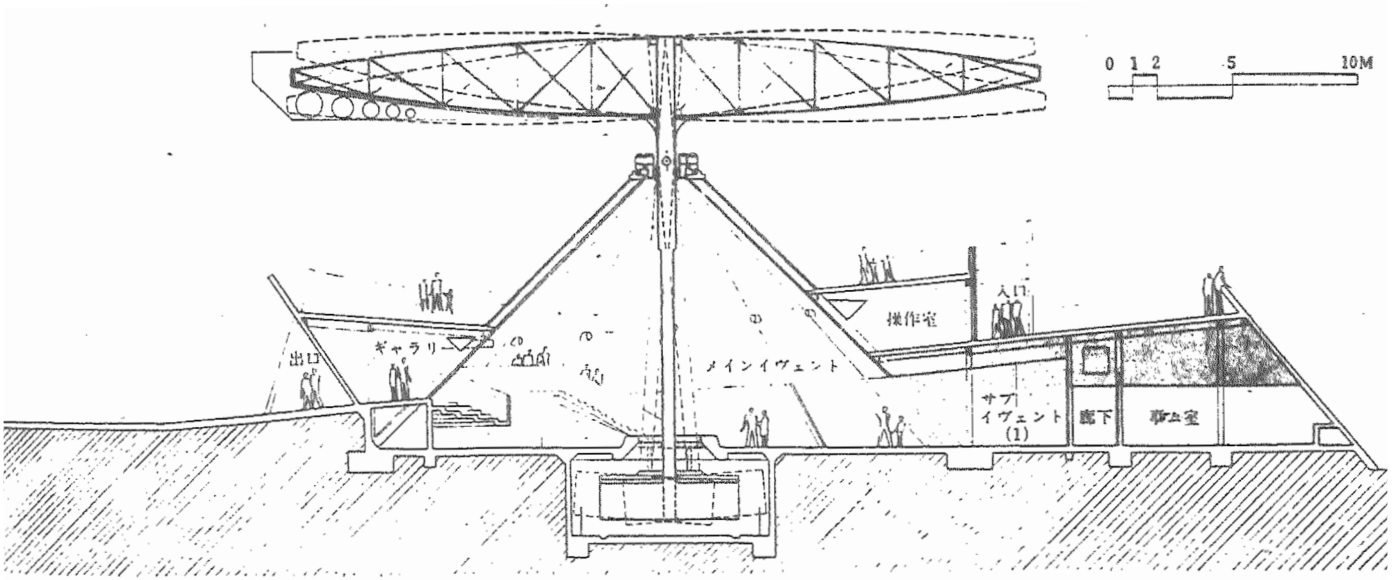

## 4.3 Wacoal-Riccar Pavilion (1970)

The World Expo in 1970 took place in Osaka, Japan from 15 March until 13 September. On the site of what is now the Expo '70 Commemorative Park, an architectural masterplan was laid out following a design by Kenzo Tange that adhered to the theme of *Progress and Harmony for Mankind*. 78 countries took part in this world fair, which attracted more than 64 million visitors. There were 116 pavilions at the Expo, sponsored by countries and corporations. The architecture of many pavilions was extraordinary, and some of them incorporated actual movement. The Canadian pavilion, for example, featured five rotating translucent discs, Hong Kong's pavilion was adorned with traditional junk sails, and the Pepsi Cola pavilion was a geodesic dome covered in an artificial cloud conceived by the artist Fujiko Nakaya.

### Appearance

Another kinetic pavilion, built around the theme of *Love*, represented the two Japanese companies Wacoal and Riccar. Wacoal was, and still is, in the business of lingerie. Riccar made sewing machines and although the brand name continues to exist, the company went bankrupt in 1984. The architects of the pavilion were Ren Suzuki and Shota Majima (Nakamura, 1970). Ren Suzuki was then a professor at Tokyo Denki University and had worked for Le Corbusier and Jean Prouvé in France (The Japan Institute of Architects Kanto-Koshinetsu Chapter, 2010). The pavilion was constructed by the firm Takenaka. During the world exhibition, the pavilion hosted 54 wedding ceremonies of selected couples with various nationalities and traditions, to showcase international wedding attire and accessories. The public could attend the ceremonies and “congratulate the young couples” (Nihon Bankoku Hakurankai Kyokai, 1972, p. 412). Two atmospheric areas in the building, the *Space of Rest* and the *Space of Love* emphasised the idea “that love is the principle source of happiness” (Komatsu, 1969).

### Moving Parts

The building stood on a square plot of 40 × 40 m and was painted white: “[T]he eternal, most primitive and purest. There is no other suitable color to illustrate *Love*—the ever-lasting theme of mankind” (Nakamura, 1970). Its concrete plinth contained a spiralling ramp that led visitors to the entrance. Curved perimeter walls outlined the routing, playfully positioned and oriented suggestive of a more flexible material that was casually draped around the central cone. From the tip of the cone, a 0.65-m-diameter tube protruded, supporting a disc-shaped roof.

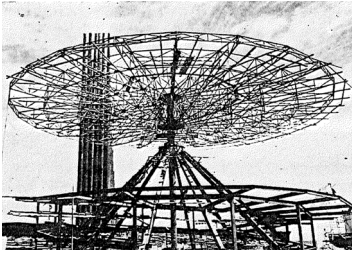

4.30 Wacoal-Riccar Pavilion.  
Construction photo.

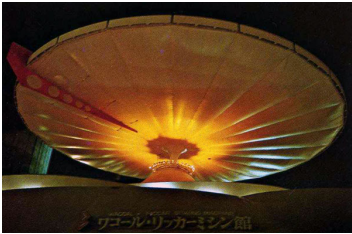

4.31 Wacoal-Riccar Pavilion.



4.32 Yajirobee, balancing toy. The toy is balanced because the centre of gravity is located below the pivot point.

4.33 Wacoal-Riccar Pavilion. Pavilion shown in context. The festival plaza by Kenzo Tange is visible in the background.

The roof (seen under construction in figure 4.30) measured 30 m in diameter, was 3.2 m thick in the centre, tapering to 0.6 m at the edges, and weighed approximately 35 t. The roof consisted of 24 segments, accentuated by a white vinyl fabric cladding that billowed from an internal radial truss structure composed of steel tubes. An overpressure in the roof was presumably present as an outward bulge can also be observed on top of the roof (e.g., figure 4.33). A prominent red air fin was radially mounted on the roof (figure 4.41).

## Movement

The concept for the roof was a traditional Japanese balancing toy called *yajirobee* (やじろべえ). In its common form, the toy (figure 4.32) balances on a tip, rotating and bobbing, while maintaining equilibrium through two counterweights on extended arms that pull the centre of gravity below the balancing point. As a *yajirobee*, the roof had only a single counterweight of 55 t positioned in the lower basement of the building. The counterweight was connected to the roof through the central tube. At 1.8 m below the roof, the tube was supported by a set of gimbaled NSK bearings that allowed the roof to rotate around the vertical axle formed by the tube and to bob out of its plane. Four spherical roller bearings in plumber blocks supported two orthogonal horizontal axles, facilitating the bobbing motion. A 2250 mm diameter slewing bearing gave the roof rotational freedom.

No drive mechanism was present, the movements of the roof were to be induced by wind and earthquakes. Rather than earthquake resistant, the structure was called *earthquake-free* because seismic shocks would be absorbed in the free movements of the roof structure (Nakamura, 1970). However, the design loads for wind were more significant than those for seismicity and with increasing inclination due to wind, the roof would be prone to even higher wind loading. Extensive wind tunnel testing at the University of Tokyo had been conducted to establish a safe design. For winds

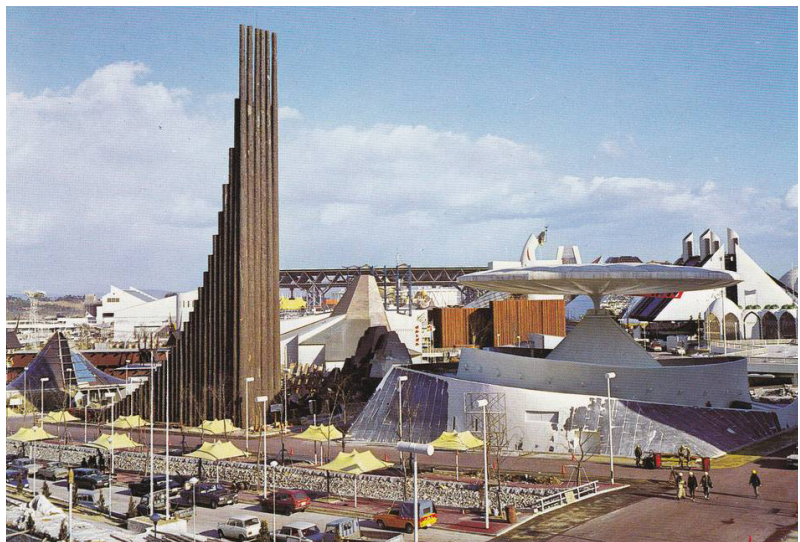



**4.34** Wacoal-Riccar Pavilion.  
Movement of the roof is (just) visible  
in a short video clip of the pavilion.

of up to 24 m/s, a counterweight only would have been sufficient to balance the roof. To withstand higher wind speeds, a series of springs was installed around the counterweight in the basement. For winds of up to 30 m/s, the roof would tilt a maximum of  $4^\circ$ . The roof was designed for winds of up to 60 m/s, but the maximum tilt would be only  $5^\circ$ . For even higher winds speeds, the roof could be locked in place.

The natural period of the roof was eight seconds, meaning that if the roof was excited, it would bob with a frequency of 0.125 Hz. The speed of movement was designed to be clearly visible, but not frightening. From a video report of the Expo '70 (Japan Association for the 1970 World Exposition, 2006), a glimpse of the movement can be witnessed (figure 4.34). The movement seems close to the natural frequency, which is a calm motion, and somehow imposing, due to the size of the roof relative to the rest of the pavilion. The wind speed, measured from the tree movements in the same scene, would be around 5 Beaufort, or 8-10 m/s. Rotation of the roof could not be observed from the video.

## Rotation

Rotation in the horizontal plane (around an azimuth axis, as a turntable) has relative advantages over other forms of movement. If the rotated system remains balanced, the drive system only has to overcome friction. Compared to horizontal sliding motion, for which this is also true, another advantage is that the guide system can remain covered and protected, which can reduce wear and blockages of the drive systems. It may also be more aesthetically pleasing to keep the mechanical systems out of sight.

Rotary systems in buildings have a long history. According to the Roman historian Suetonius, emperor Nero's palace had a revolving banquet room that "was circular, and revolved perpetually, night and day, in imitation of the motion of the celestial bodies" (Randl, 2008, p. 360). Although the existence of the room in that exact form is still contested, the rotating room as a status symbol for the powerful has had an effect on buildings in the centuries that

**4.35** Revolving restaurant in  
Fernsehturm, Berlin.



followed. It promoted a self-centric view where occupants literally saw the world turn around them. The rise of viewing towers with revolving restaurants can arguably be regarded in a similar way, as a symbol of technological prowess, selling visitors a special position. The *Fernsehturm* that was opened in 1969 in East Berlin is a striking example (figure 4.35). But rotating prisons have also been built, inverting the power relations and preventing the prisoners from cutting the bars.

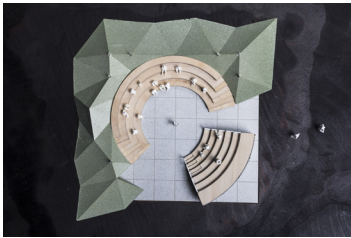

4.36 OMA, MPavilion 2017.

But rotation has not just been political, expressing relations of power. Windmills that could be rotated in (and out of) the wind have been constructed since the twelfth century, and optical telescopes rotate around an azimuth axis to track the night sky as the earth moves, as do the buildings that protect the telescopes, their enclosures. Many theatres have been proposed and built that feature rotating stages. The scheme by Walter Gropius for his *Total Theatre* is a famous example, although it was never built. The proposal for OMA's 2017 *MPavilion* in Melbourne, Australia, featured a rotating section of the tiers to allow for multiple configurations, suggesting perhaps a reference to Gropius' design (figure 4.36). Tracking the sun, simulating heliotropism, was incorporated in Angelo Invernizzi's *Villa Girasole* (1935) in Marcellise, Italy. Running on train wheels and centred by a large roller bearing under the building, the villa could complete a full rotation in nine hours and twenty minutes. Richard Foster's *Circambulant House* (1968) in Wilton (CT), US, rotates on top of a pedestal in order to change the view from within the house. More contemporary examples are the *Suite Vollard* (2004) apartment tower in Curitiba, Brazil, which has eleven revolving apartments on top of each other. And Next Office's *Sharifi-ha House* (2013) in Tehran, Iran, features three rotating rooms that can provide both *extroverted* and *introverted* orientations (Next Office, 2014).

## Wind

The examples of rotation in buildings feature movement in order to provide some functionality, but the movement itself is quite uneventful. Dining in a revolving restaurant might be exciting at the start of the event, for example, but the novelty quickly wears off and the constant motion becomes a new stasis where movement is merely self-referential, relating to nothing other than its enabling mechanism.

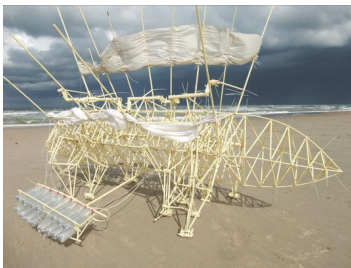

4.37 Theo Jansen, Strandbeest  
Animaris Adulari.

Movement that is driven by wind may display some of the chaotic dynamics that are characteristic of turbulent airflows. However, not many buildings are driven by wind. The *Glasgow Wing Tower* (2001) in Glasgow, Scotland, rotates in the wind to reduce wind loads, but it rotates by means of a powered drive mechanism. A design for a tornado-proof house was patented in 1890, but was never built (Blanchard, 1890). Its aerodynamics would turn this house into the wind, reducing the overall wind loads.

Wind has been an inspiration for many artists and architects to drive motion into their kinetic systems. A fascinating series of



works is *Strandbeest*, a creation by artist Theo Jansen. Made of PVC tubes, PET bottles and cable ties, these intricate machines move autonomously across the beach and sometimes showcase complex behaviours such as stopping or reversing at the water line. One example *Strandbeest*, *Animaris Adulari* (2012), features sails that flap in the wind, driving crankshafts, pressurising bottles to store potential energy, and ultimately releasing this energy to drive a complex walking mechanism (Exploratorium, 2016) (figure 4.37).

The roof petals for Amanda Leveté's 2015 *MPavilion* in Melbourne's Queen Victoria Gardens (figure 4.38) were swayed by the wind. The thin petals, measuring up to five metres wide, formed a layered staggered roof made of a translucent composite with carbon fibre. The petals were supported by 95 slender carbon-fibre columns, some of them flexible enough to make the petals shiver in the wind. The resulting space underneath the roof would be marked by shifting patterns of light and shadow exposing a certain sensitivity to the weather.

## Coupling

We could say that buildings like the *Wacoal-Riccar Pavilion* and *AL\_A's MPavilion* engage in a relation with the weather. Their movements are somehow coupled to the wind. Although these structures do little to influence the air flow upstream, their response to it varies with motion. An object that is set in motion by wind will respond to the same wind differently and may, for

4.38 AL\_A, *MPavilion* 2015.



example, be excited in a mode of resonance. Occupants perceiving this motion are not just experiencing the wind. The building does not merely function as an instrument that can be read, like an anemometer. Rather, the building has a particular response to the wind that is enacted in the case of the *Wacoal-Riccar Pavilion* as a rotation and bobbing motion. In the case of AL\_A's *MPavilion*, this is a gentle sway of some of the petals. Occupants visually perceive this motion, hence enhancing their own sensitivity to the weather, but *through* the particular enactment of the building. Therefore, the sensitivity is unique for being in that building. Remaining in that building longer and learning its response to various conditions no doubt would deepen this sensitivity, not dissimilar to knowing the particular creaks and squeaks of the house one lives in. A coupling therefore not only exists between the building and the weather, but this coupling is extended to the occupant.

Ultimately, the coupling suggests an idea of balance. Not a condition of stasis, but a dynamic equilibrium between the building and its occupants that forms over time. In fact, the idea of balance was distinctly present in the design of the *Wacoal-Riccar pavilion*. Most clearly in the manifestation of the roof, but one could be tempted to read the uneven ramps and the maze inside the pavilion as deliberate interventions to question the sense of balance.

The Brazilian designers Rejane Cantoni and Leonardo Crescenti do this by making floors move. In works such as *Piso* (2007), *Túnnel* (2010), *Solo* (2010), and *Melt* (2014), they explore balance through floors that become unstable when crossed. In *Solo* (Soil), for example, the floor is made of rigid panels connected with hinges that tilt when they are stepped on (figure 4.40). Because of the connections, other parts of the floor also tilt in a zig-zag manner. This behaviour becomes more complex when multiple people cross the floor. The effect of the moving floor is emphasised by reflections off the shiny surface that amplify the movements as they cause light patches on the surrounding walls.

The typical abstract settings of the pieces by Cantoni and Crescenti, in spaces with empty walls and little context, a visitor's sense of balance can only be found within themselves. However, a context, such as the windy environment of the *Wacoal-Riccar Pavilion*, allows a balance to be found in relation to the conditions, in a coupling with the environment.

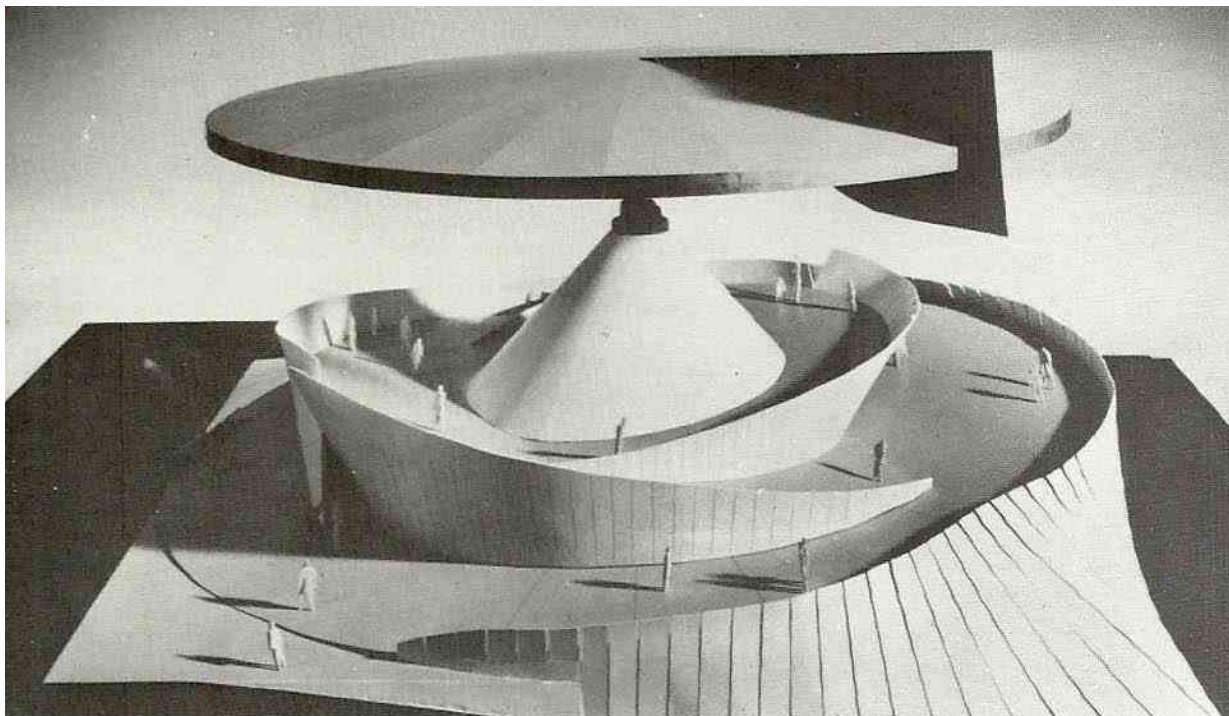

4.39 Wacoal-Riccar Pavilion.

4.40 Cantoni Crescenti, Solo.

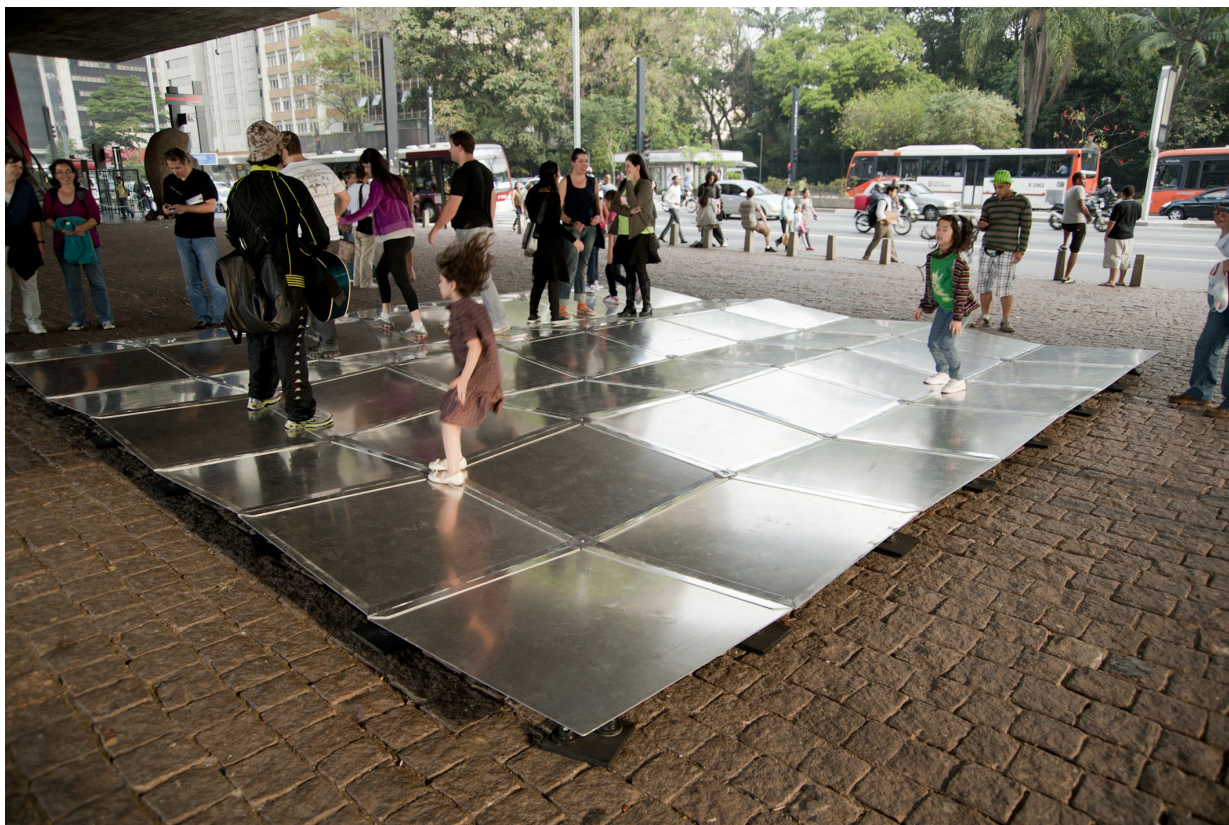



4.41 Wacoal-Riccar Pavilion.





## 4.4 Maison à Bordeaux (1998)

OMA's Maison à Bordeaux from 1998 is a private residence in Floirac, France, a municipality bordering on Bordeaux. The building was designed as a family home for Jean-François and Hélène Lemoine and their three children. Mr. Lemoine was wheelchair bound (after a car accident in 1991), which inspired many of the building's characteristics. By 1988, Lemoine had already contacted OMA/Rem Koolhaas, Frank Gehry and Herzog & De Meuron regarding a private house in Bordeaux, but the commission was not given directly to Koolhaas until 1994. The choice for OMA was influenced by its approach to Lemoine's disability. As Koolhaas subsequently said: "It was not a case of 'now we're going to do our best for an invalid'. The starting point is rather a denial of invalidity" (De Haan, 1996). This aligned with the wishes of Lemoine, who had felt imprisoned in their old house in Bordeaux: "Contrary to what you would expect,' he told the architect, 'I do not want a simple house. I want a complex house, because the house will define my world...'" (Levene & Márquez Cecilia, 1996, p. 164). Construction of the house started in 1996. The building has been listed as a historic monument in the Mérimée register since 2002.

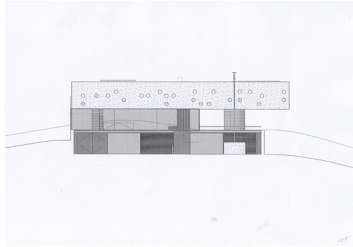

4.43 Maison à Bordeaux. OMA design drawing, elevation.

### Appearance



4.44 Maison à Bordeaux.

The building is located on a hilltop overlooking Bordeaux. The main house has three floors bordering on a courtyard and a caretaker's house. The house is formed by three distinct stacked volumes. From the courtyard, one enters the lowest volume, which is mostly inserted in the hill and contains the kitchen and dining area. The space is cavernous with nooks and crevices formed by curved walls in an irregular plan. Level with the garden, the second volume is transparent. With a floor-to-ceiling glass facade, about half of this volume is indoors, while the other half forms an outdoor terrace featuring a shining silver cylinder containing a staircase. Curtains can be deployed along the whole perimeter, creating a quasi-indoor terrace. The top volume holds the sleeping quarters and bathrooms for the parents on one side and the children on the other. Both sides are individually accessible. This volume is the most striking. Thick concrete walls in a greyish brown colour, perforated with circular windows, define a heavy volume that seems to float on the glass layer below. A constellation of distinctive structural elements in white and black keeps the box afloat.

The gravity-defying arrangement of the building was developed in collaboration with structural engineer Cecil Balmond, who was then at Arup. Koolhaas and Balmond had previously worked together on projects such as the *Kunsthal* (1992) and *Euralille* (1994). Various options for making the top volume float had been considered, including cantilevering the volume from the hill, via supports concealed in the geometry of the volume or even through a cable-stayed solution, effectively hanging the volume from cables and an external structure. A solution was later adopted that

4.42 Maison à Bordeaux.







would add stiffness to the volume by tying the long walls together through transverse walls, floor and roof sections. This concrete box was supported on a steel portal frame on the hillside, and the cylindrical core on the valley side. The core was “deliberately offset to add drama” (Balmond, 2007, p. 30), thus introducing the need for another element to stabilise the structure. A 1100-mm-deep I-beam with a double web was positioned on the roof, visually similar to that used in the *Kunsthal* in Rotterdam, Netherlands. The beam externalises the forces originating in the eccentricity and conducts them through a vertical tension rod to a foundation block under the courtyard.

## Moving Parts

The centrepiece of the house is a moving platform that links the three volumes together. The platform measures  $3 \times 3.5$  m and was furnished as Mr. Lemoîne’s office. Not only would this allow him to travel easily between the levels, but his entire office would travel with him. Lifted by a hydraulic ram that was installed in a special basement under the shaft, the platform could move from floor to floor or remain suspended in between. The hydraulic piston is a single tube with housing that is recessed into the ground under the platform shaft. Every floor has its own barrier system that automatically deploys when the platform is not there. In the kitchen, this barrier is a full-height glass sliding door. On the next level, the shaft is open on three sides and a railing slides up vertically from inside the shaft. On the top level, a flap hinges up to act as a fence. The platform itself has no railing, but infrared sensors detect objects near the four edges and vertically across the shaft. Magnetic position indicators allow the platform to stop at each floor, but overrides exist for custom locations. The platform moves at 0.16 m/s.



4.46 Maison à Bordeaux. Platform in topmost position.

The platform was designed and fitted as a moving office for Mr. Lemoîne, the floor finish matching that of the intermediate level. One side of the shaft provides a certain continuity through a three-storey-tall bookcase, but even so, the character of the office changes with each position. A roof light on top of the shaft is the same size as the platform and appears increasingly bright as the office travels towards the light. A rolling curtain can be deployed to darken the space. At the highest level, the office is secluded, open only on one side, and a work by Gilbert & George adorning the opposite wall. On the level below the office is open to three sides and there are views out, all the way down to Bordeaux. At the lowest level, the office has access to a wine cellar and becomes part of the bustle of daily life, next to the kitchen and the entrance to the house. The user of the office chooses which part of the house should be brought towards the office. The moving room allows the building to be reconfigured according to the user’s wishes or needs. If the house itself does not become a machine, then at least it contains an architectural machine that allows the house to be lived in.



4.47 Maison à Bordeaux. Platform descending.



4.48 Vladimír Karfík, Bata Elevator Office.

## Movement

The moving platform and its machinery had already been portrayed in Koolhaas' book *Delirious New York* (1978). Identified as one of two trends that unlock the potential of high-rise building (the other being the use of steel to construct frame structures), the invention of the safety lift by Otis “recovers the uncounted planes that have been floating in the thin air of speculation and reveals their superiority” (p. 82). A full-page photograph further reveals a fascination with a building's backstage machinations; a group of Roxyettes in the depths of Radio City Music Hall's enormous complex stands next to a set of hydraulic “huge gleaming pistons” (p. 214), not dissimilar to the version that would be later installed in Bordeaux. But another narrative is provided for Bordeaux. Due to the nature of the Dutch waterways (OMA's office used to be along the river Maas in Rotterdam) with their many low bridges, a mobile steering cabin has emerged for freight barges that can be lowered with each bridge. For some vessels, the steering cabin has developed into a living room for the captain and captain's family, resulting in entire rooms moving up and down. Koolhaas explains: “This principle seemed ideal for the Bordeaux house, which required a device that could function both vertically and horizontally as a programmatic component of the floor” (Jacques, 1998, p. 92).

In her thesis about the Maison à Bordeaux, Beatrice Lampariello provides other architectural references (2011), for example that there is a similarity between the platform in Bordeaux and Le Corbusier's *Cabanon* (1951) in Roquebrune-Cap-Martin, France. If the entrance hall and the toilet of the *Cabanon* are discarded, we can indeed see that the outline dimensions of the two floor plans are very similar. But perhaps a more striking reference is the vertically moving office that was designed by Vladimír Karfík, a former assistant to Le Corbusier, for the Bata shoe factory in Zlín, Czech Republic (1938). Apart from a working telephone, the office had running hot and cold water and could move up to the sixteenth floor to monitor progress in the entire factory (figure 4.48).

In the film *Koolhaas Houselife* by Ila Bêka & Louise Lemoine (Bêka & Lemoine, 2008), we follow Guadalupe, the cleaner of the house in Bordeaux. Along the way, we get an impression of how it is to live in this house. Apart from its many qualities, we quickly understand that living in an experimental house requires a flexible mindset to face its drawbacks. Not only does the building leak when it rains, and doors get stuck, Guadalupe explains she does not like using the moving platform because it got stuck between two floors one day. As a consequence, she confronts the perilous conditions of the narrow spiral stairs with all her equipment. Watching the film, Koolhaas observes: “You see two systems colliding. The systems of the platonic conception of cleaning with the platonic conception of architecture. It is not necessarily daily life confronting an exceptional structure, it is two ideologies confronting each other” (Bêka & Lemoine, 2013). He says it further reminds him of how the population of Lagos adapts to the realities of life in urban conditions of decline.

“Like the elevator, each technological invention is pregnant with a double image: contained in its success is the specter of its possible failure” writes Koolhaas in 1978 (Koolhaas, p. 27). In the reality of the intricate mechanisms that comprise the house in Bordeaux, and especially those of the moving platform, this seems particularly true. The peculiarities of moving systems are often at odds with those of a building and its traditions of construction and maintenance. The Maison à Bordeaux would not be the first architectural application of certain machinery to face mechanical failure. In fact, the lifting system was hampered by malfunctions throughout its early years, even after several repairs. This had been troubling to the owners, who wrote to the contractor in January 2000 that they were aware of the prototype nature of the platform, that they had agreed with a long development time, but that their patience had now run out: “Vous avez souvent évoqué le caractère de prototype de cette plate-forme et il était convenu que le temps de mise au point serait long mais aujourd’hui nous sommes bien au-delà de l’acceptable” (Lampariello, 2011, p. 232). As the problems persisted throughout the year, this meant that the platform had been of limited use to Mr. Lemoine who passed away in February 2001.

## Stability

The notion of stability has played an important role in the design of the house, and not just in relation to the moving platform. The purpose of shifting the structural frame to break symmetry and introduce the need for the overhanging beam with tension rod and counterweight was a deliberate decision to create a sense of

**4.49** Maison à Bordeaux. Platform in topmost position, the piston clearly visible.



imbalance and precariousness. Balmond explains this in his project history and concludes that both Koolhaas and he felt they had succeeded: “It was dramatic, brutal and exciting” (Balmond, 2007, p. 44). Balmond also refers to the design process itself in terms of stability. Comparing a stable configuration with one of instability (illustrated with a ball either at the bottom of a valley or at the top of a hill), he suggests that a design process that starts in tradition will eventually end up with similar solutions to what we already know, no matter how much we experiment. The ball will eventually roll back to the bottom of the valley. To the contrary, if we start on the hill in the unstable condition, the process will always lead us further, away from the origin into the unknown (Balmond, 2007).

The platform can also be seen to disturb a sense of equilibrium. First, it reconfigures the house with every move. It either adds floor and ceiling, or it leaves a gap. It provides a throughway, or its absence blocks a path. Its absence leaves a memory of when it was, and makes one wonder where it is, the gleaming piston providing a clue. The room at the top of the house is strangely empty without furniture and floor. The wine cellar inaccessible without the platform present. There is the joy of finding it and at the same time sensing its potential for change. When it completes one floor, it always leaves the others incomplete. A constant agitation of forces pushing and pulling towards a next state of imbalance. Second, it inverts the conditions of permanence and change. Where typically one would regard the bulk of the building as representing the permanent condition and the elevator as representing the moving element that changes, to those residing in the office on the moving platform, the platform may well become their perceived condition of permanence. In an abstract sense, we could discuss this in similar terms as with the revolving building. The power relations there suggested that the occupant is at the centre of everything, with the world revolving around them. In a similar way, the factory of Jan Antonín Bata placed him and his moving office at the centre of the factory, wherever he was.

But in a more literal sense, the sensation of permanence could also reside on the platform, depending on some physiological factors. With the emergence or revival of virtual reality, there is an interest in providing users with the sensation of movement when there is no or very little movement. Visually induced illusory self-motion is known as *vection* (Hale & Stanney, 2014). The sensation occurs, for example, when you are seated in a stationary train at the station and see another train depart. The opposite effect also exists and is the illusion of no movement, when in fact there is. This may be experienced on a large ferry that leaves the quay. The conditions for this to occur are slow accelerations under about  $0.05 \text{ m/s}^2$  (Jones & Young, 1978; Lawson & Riecke, 2014), noting that the body is not sensitive to velocity per se, but to accelerations. However, this number is not a firm limit—a frequency dependent threshold for motion sensitivity in high-rise buildings is set out by Burton (2006). The threshold value further varies with the orientation of the movement relative to the head, where the body is more sensitive to vertical motions.

From personal experience, after an improvised short experiment in one of the four glass passenger lifts at IT University, it seemed

difficult to apply a sense of permanence to the elevator. Even though I had brought a chair and a computer to do some work in the lift, I could not convincingly perceive the building to move around me. I have assumed that the inversion of permanence and movement would be similar to looking at a bistable image (e.g. a Necker cube) and *flipping* the perception, but it proved harder than that. As the literature suggests, the sensation of other phenomena than those purely visual play an important role. The ride on the elevator was certainly bumpy with stops and starts clearly discernible. Such an inversion would be more plausible in a revolving restaurant that moves continuously at a low speed, although this remains untested.

From the history of the mechanism in Bordeaux, we know that the platform operation was initially noisy, and acceleration was *brutale* (Lampariello, 2011). From observing video of the platform moving in the documentary by Bêka and Lemoine (2008), it seems that the movement of the platform itself is smooth, but that starts and stops would be clearly noticeable. A sense of inverted permanence might therefore occur during the platform movements between starts and stops. In fact, a short section in the documentary suggests this might be the case: while the platform moves, the focus is on the desk on the moving platform, and it is momentarily unclear what is moving and what is not.

Apart from questioning stability itself, the inversion of perception of movement that occurs on the platform also lays bare some of the workings of human perception of movement. Even at very slow or smooth movements, the actuator would *know* it was moving, contrary to the human occupant. The sensitivity for movement can be bypassed, by design, to avoid a sensation of movement, or to mislead the occupant. The tension between what is perceptible and what is not might be understood as an investigation of movement not unlike the explorations of the kinetic artists working from the 1950s to the 1970s.



4.50 OMA, Prada Transformer.



4.51 OMA, Prada Transformer. Four mobile cranes change its orientation.

## Resonance

OMA has a relatively rich portfolio of movement in architecture. Other than the House in Bordeaux, projects that deal with actual movement are for example the *Prada Transformer* (2009) in Seoul, Korea; *Garage Museum of Contemporary Art* (2015) in Moscow, Russia; and the *Fondation d'Entreprise Galeries Lafayette* (2018) in Paris, France.

*Prada Transformer* (figure 4.50) was a temporary structure that could be repositioned by a number of mobile cranes (figure 4.51). All sides of the structure would provide a different floor plan. Repositioning the structure would reprogramme the building for three months, in order for it to host a film festival, a fashion and art exhibition and a fashion show for Prada.

The *Garage Museum* features an 11-m-wide section of the main facade that can be lifted vertically to open the double-height space

behind it. This large gesture signals that the museum is open. During the design, it was envisaged that a large grill floor could move up and down in the void to provide for smaller or larger artworks to be exhibited. For reasons relating to planning and certification, this part of the project was abandoned (Chris van Duijn, personal communication, 30 August 2017). In the early design stages, also the *Kunsthal* (1992) in Rotterdam, Netherlands, featured a moving platform that would reconfigure the space (figure 4.53).

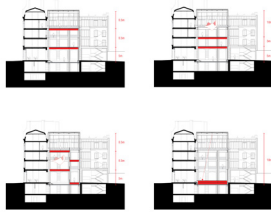

4.52 OMA, Fondation d'Entreprise Galeries Lafayette. Drawing showing configurations of the four movable platforms.

*Fondation d'Entreprise Galeries Lafayette* is a creative and cultural centre in central Paris. The project is a refurbishment of a 19th century industrial space with a courtyard. A steel structure has been placed in the courtyard that houses four mobile platforms that can move up and down independently. Organised in two shafts of different dimensions, the two segments in each shaft allow for a multitude of configurations (figure 4.52).

4.53 OMA, Kunsthal. Design drawings, showing configurations with a movable platform. The platform was not realised.

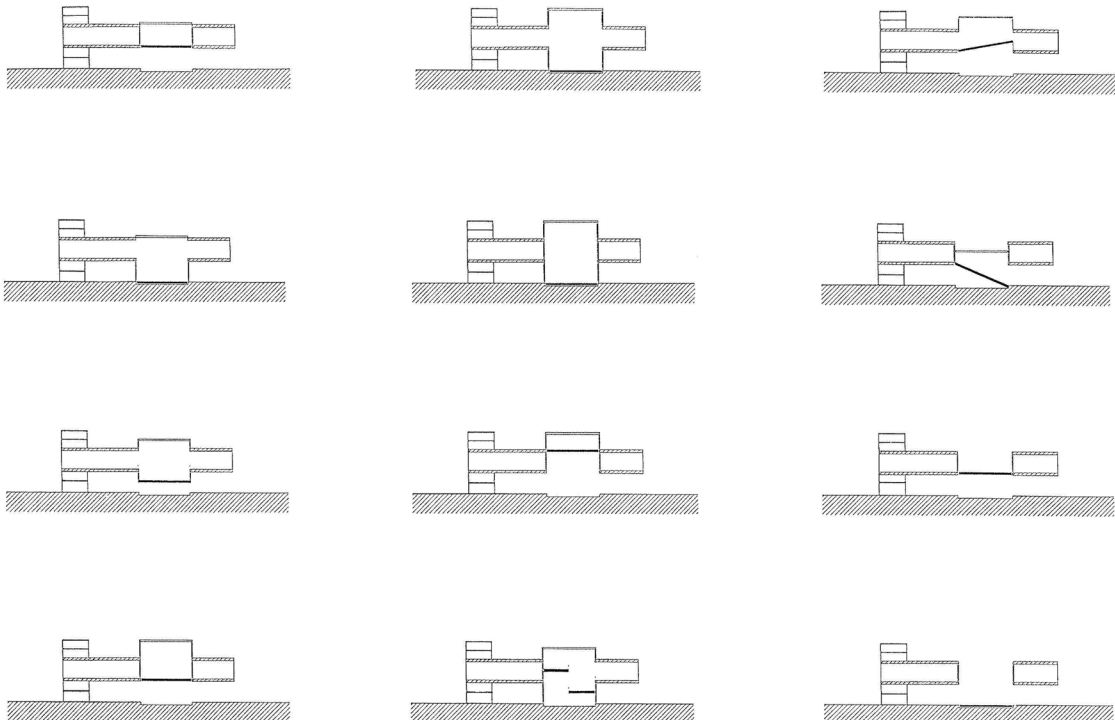





## 4.5 Blur Building (2002)

Elizabeth Diller and Ricardo Scofidio started collaborating in 1979 when they created their studio (D+S) in New York. Their work was an interdisciplinary mix of art, architecture, new media and performance. They liked to work as outsiders. When asked which discipline they consider themselves part of, they would say: “We tell the architects we’re artists and the artists that we’re architects” (Marotta, 2011, p. 9). In 1998, D+S was invited by Adriaan Geuze of West 8 to take part in a competition for one of four sites of the Swiss national exposition, at that time planned for 2001. The exhibition would take place on four *arteplages*, waterfront locations by the lakes of Neuchâtel, Bienne/Biel and Murten. The Extasia team, as they named themselves, further consisted of Vehovar & Jauslin and Tristan Kobler, both Swiss architecture practices. The combined proposal was for a landscaped forum on the shore of any of the four locations, with a number of architectural interventions on shore and a media pavilion above the surface of the lake.

The ambition for the team had been a *democratic collaboration*, where all team members would be responsible for the whole project. But internal friction in the team even before the competition submission led all members to work on their individual sub-projects, according to a dramatic rendition by Diller and Scofidio (Diller & Scofidio, 2002). *Blur Building* was one of those sub-projects, but has arguably overshadowed the other projects as the locus of architectural and intellectual interest. A building was made without walls or a roof, but as a cloud of water vapour continuously ejected by a grid of nozzles. The selected site became the lakeside of Lake Neuchâtel at Yverdon-les-Bains, Switzerland. *Expo.02* took place from 15 May to 20 October in 2002.

*Blur Building* sought to be a counterpoint to traditional pavilions and events at national and world exhibitions. Such exhibitions often gave expression to views of the future, and had become spectacles in their architectural manifestations and by means of increasingly abundant media content. *Blur Building* would be the opposite: a *spectacular anti-spectacle* that would provide visitors with *nothing to see and nothing to do* (Diller, 2008). Throughout the design however, the pavilion had been thought of as a media pavilion, and the integration of some digital media technology, albeit in a lo-res form, had been imagined in different ways. Various proposals had been made for the media content of the pavilion, such as a real-time 360-degree video panorama at the heart of the building and the use of *braincoats*, which were electronically enhanced raincoats that would store a personal profile of the wearer and interact with other *braincoats* in the pavilion. Due to various set-backs and budget cuts during the development process that even threatened to compromise the whole project, these content proposals were not implemented in the final design, apart from a sound sculpture by Christian Marclay.

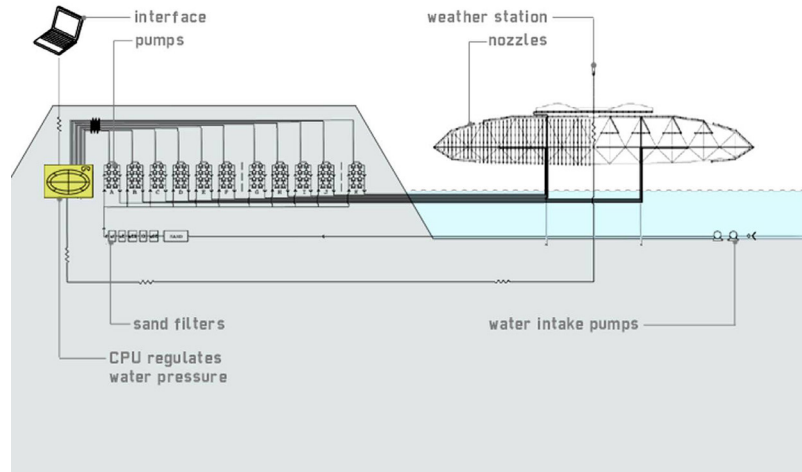

4.55 Blur Building. System diagram.

However, the medium of water itself was also digitised. The spray nozzles can be read as an array of output points, controllable from a central computer (figure 4.55). Environmental conditions would be constantly monitored by sensors for temperature, humidity, wind speed and direction, and dew point. At eight-minute intervals, the system would update its response in terms of pressure and distribution of the water in the system. A central computer had been taught a number of response scenarios based on actual weather conditions (Diller, 2008). As soon as mist was produced, it would mingle with the surrounding air, the artificial digital weather engaging in a more analogue relation with the natural weather.

4.56 Blur Building. Drawing of building's steel structure.

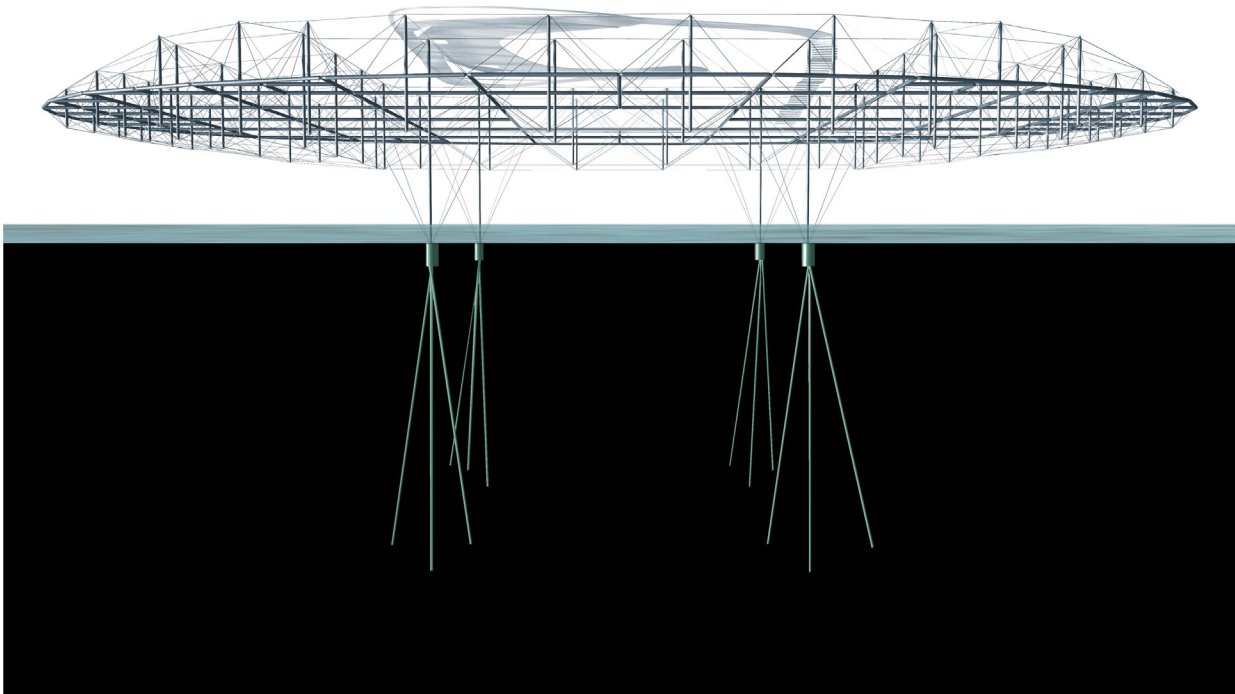

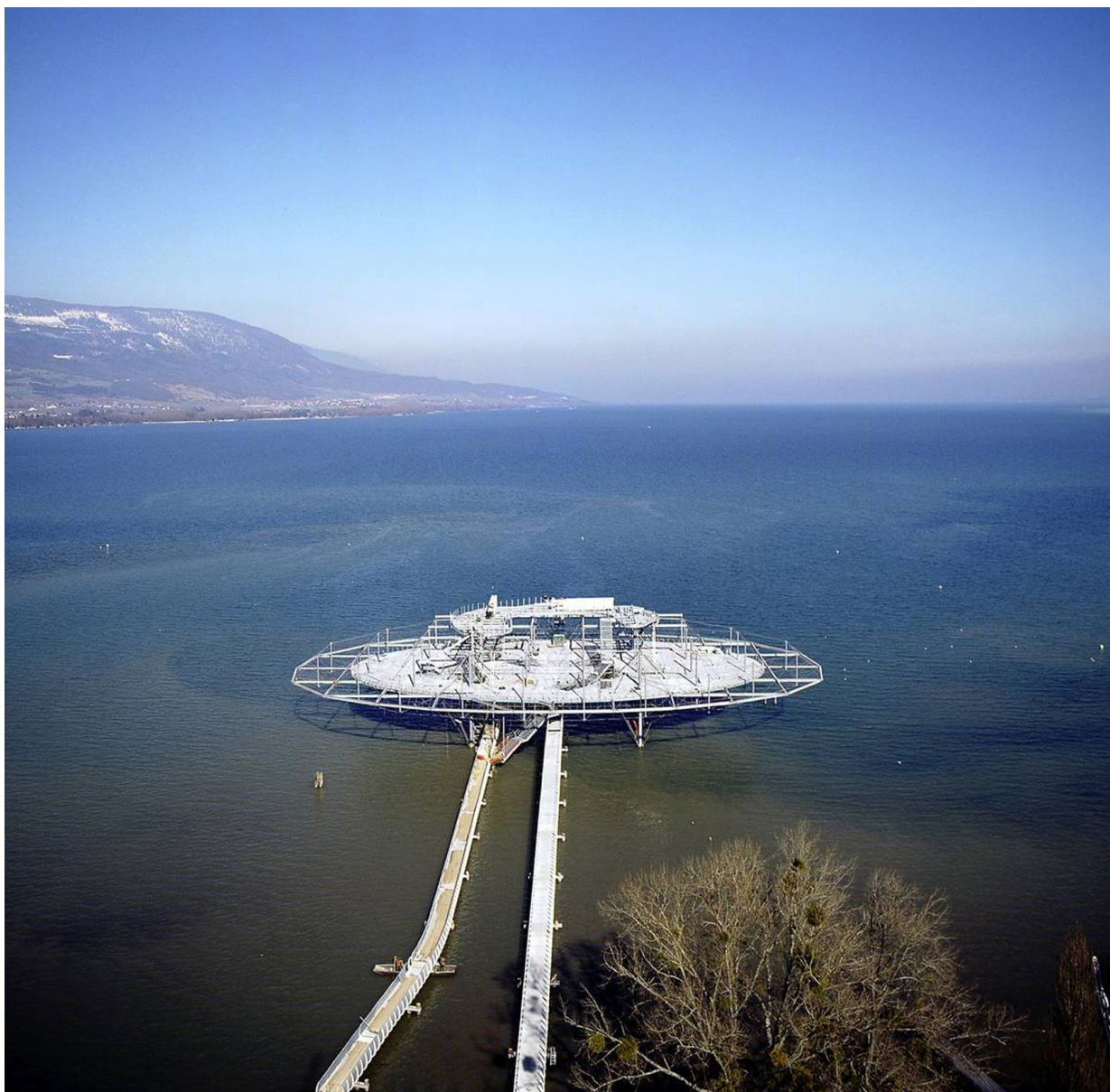

4.57 Blur Building. While the cloud is turned off, the steel structure is visible.

Despite the compelling rhetoric of the architects, there were things to see and things to do in the pavilion. Apart from observing the constantly changing conditions, visitors could enter a viewing platform, overlooking the pavilion, the lake and the lakeside plan (visible in figure 4.57). The pavilion also featured a water bar, serving waters from all over the world. This included water from the lake below, the very material the building was made of (Diller & Scofidio, 2002).

### Appearance

*Blur Building* was an atmosphere, a fog that visitors would enter, experiencing the sound of white noise and a visual white-out, rendering the normal dependency on vision largely ineffective. The building was formed as a cloud, a building made of water





4.58 (page 186-187) Blur Building. Bird's-eye view.

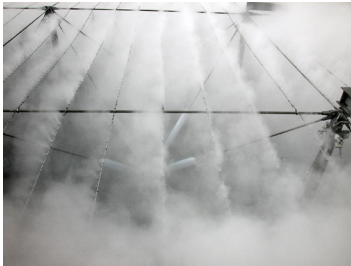

pumped from the lake and vaporised through special spray nozzles mounted on a steel skeleton structure. The steel structure of the pavilion provided the platforms and the ramps, and supported the fog infrastructure (figures 4.56 and 4.57). It was a combination of structural systems. A horizontal layer at approximately 11 m above the lake was oval in outline, measuring 100 × 60 m. This layer was supported by four columns at 30-m spacing standing in the lake, about 150 m away from the lakeside. Its beams were organised on a grid of 10 × 10 m, with smaller quads and triangles along the edges. The beams of the grid acted as the edges of bipyramidal tensegrity units. A vertical strut of maximum 10 m that was shorter towards the edges of the oval, was suspended in each quad by tension rods connecting the corners of the quad to the ends of the strut. Further tension rods connecting the tops and bottoms of the struts supported the nozzle lines, spaced at approximately 1.1 m. A viewing platform at 19 m above the lake was constructed on top of the frame. Although it was supported on the columns in the tensegrity frame, this structure followed a different logic in order to accommodate the freeform curved shape of the viewing platform.

## Moving Parts

4.59 Blur Building. Nozzle lines.

To create a dense fog, water from the lake was pumped and fed to 35,000 nozzles (the exact number varies in different sources), spaced at 20-cm intervals along the nozzle lines, leading to a nozzle density of 4.5 /m<sup>2</sup> (figures 4.59 and 4.60). To avoid blockage of the nozzles and to provide a safe environment for visitors, the water from the lake was filtered in a filtering installation below the main platform. Directly after the pavilion opened, problems with the filter installation had made it impossible to safely use water from the lake. Until the filtering system was once again calibrated and tested, city drinking water had been used as a temporary solution to form a cloud, but the supply only met about half of the required capacity for optimal operation of the building.



4.60 High-pressure nozzle in test setup.

Given the complexity of the interacting weather systems, it would have been meaningless to do computer simulations of these processes for the purpose of making design decisions. Although the original competition had been won with a set of computer renderings, what the fog would look like in reality, as well as how it could be realised was largely unknown at that time. The importance of full-scale tests was therefore highlighted early in the process, but met resistance from the building contractors, who were quoted as muttering: "A cloud is a cloud is a cloud" (Diller & Scofidio, 2002, p. 270). Though, given the significance of the cloud and its many unknowns, it is understandable that the architects insisted on the tests taking place. The initial experiments were done with minimal enthusiasm by the contractor, which showed in a test rig that was so poorly constructed that it collapsed due to wind loads. But it was only through these tests that the final density of the nozzles could be determined, which was significantly higher than initial calculations had shown (Dimendberg, 2013; Incerti, Ricchi, & Simpson, 2007).

4.61 Blur Building. View of the walkways leading to and from the pavilion.



## Movement

Visitors to the *Blur Building* would walk across a lightweight fibreglass bridge (figure 4.61), a straight line, slightly sloping up, leading them from the mainland to the mist. The demarcation between being inside and outside would be ambiguous. One was entering the pavilion gradually, to find oneself at some point surrounded by an opaque drizzle and a disorientating white noise. The silhouettes of other visitors would now and then appear, only to be gone the next moment. The architects had intended a thick mist to form the volume of the building, but the homogeneity would be disturbed by gusts of wind, especially if weather conditions changed quickly. As Ashley Schafer witnessed, certain areas of the pavilion could become devoid of mist and were then suddenly engulfed by it (Schafer, 2003).

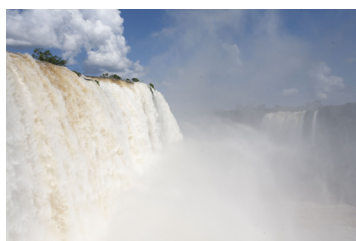

4.62 Iguazu Falls.

Available video (The Fog System, 2011) of being inside the pavilion shows conditions that seem to resemble standing in the spray of a waterfall. Looking down the *Garganta do Diablo*, the largest of the Iguazu waterfalls on the Brazilian–Argentine border, from a viewing platform downwind, would provide a similar immersive experience (figure 4.62). The wet mist, the loud noise, and the overwhelming power of persistence in both cases are brought forth by systems that constantly produce nothing other than themselves. Only on the viewing deck would one escape the disorientating grip of the pavilion, and look out over the cloud—stretching, breaking, drifting across the lake.

The artificial and natural weather systems formed a complex and coupled system. Atmospheric conditions around the pavilion would dictate the distribution of water to the various zones of the fog system, but also the pressure at which water was vaporised. Locally, the fog would also affect the environmental conditions. Not only directly by adding moisture, but also indirectly as fog tends to cool down its direct environment, thereby activating air currents. Ashley Schafer describes the manifestation of this dynamic:

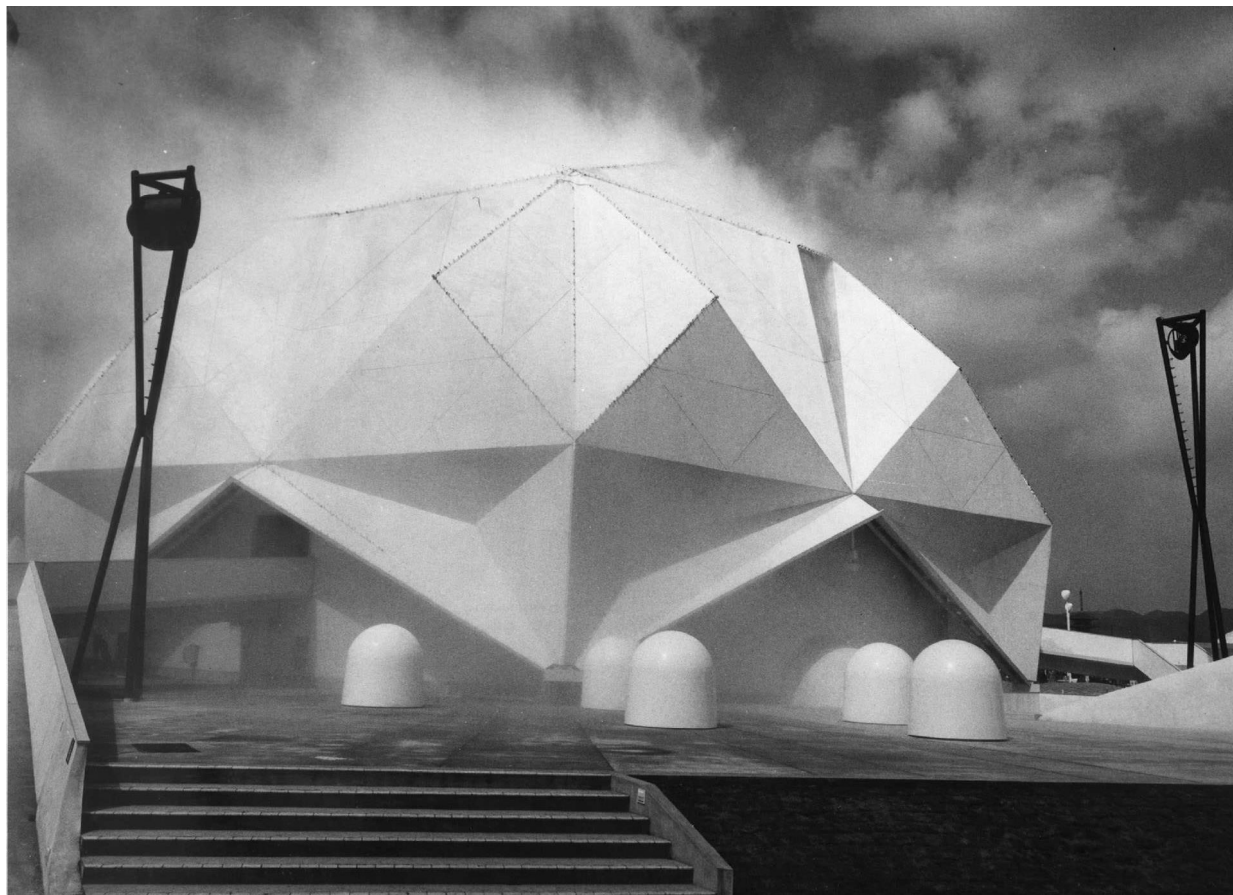



A stiff wind, interacting with increasing nozzle pressure, would sharply define the leading edge of the “nothing.” The atomized water appeared skinlike, draped between and pulled taut against the ridges of the fog nozzle lines. When the water was warmer than the air, the mist would form a rapidly rising mushroom cloud, and when convection currents rose from the lake, the leading edge seemed to roll. When the wind stilled, Blur’s edge became diffuse, soft, and permeable, dissipating so gradually in all directions that it was difficult to say where it ended—but always it was moving: rolling downward, lifting up, floating outwards, drifting low along the water. (Schafer, 2003, p. 100)

## Resonance

A cloud building had been previously conceived for the world exhibition in Osaka in 1970. A corporate pavilion for Pepsi was built as a white geodesic dome that was 45 m wide and 23 m tall (figure 4.63). Pepsi had invited the collective Experiments in Art and Technology (E.A.T.) to design the pavilion and produce the content for the duration of the exhibition. The theme for the pavilion was *World without Boundaries*, which was manifested in a soft dynamic mist that obfuscated the hard skin of the building. The artist Fujiko Nakaya, known for working with fog as an artistic material, collaborated with engineer Thomas Mee to create the artificial cloud around the Pepsi pavilion, the largest cloud she had created until then. 2500 custom-made nozzles were distributed along the ridges of the dome, spraying 230 tons of water per day. At night, the cloud was dramatically lit by beams of xenon light (Nihon Bankoku Hakurankai Kyokai, 1972). In a documentary video of the project, Nakaya describes the work as a *negative sculpture*, shaped by the external forces of the weather conditions (“The Great Big Mirror Dome Project (1970),” 1969). Nakaya and Mee give detailed accounts of the process that led to them using water vapour to create the fog, and of the development of the nozzles. Various trials were conducted in different climate conditions, as well as wind-tunnel tests to establish the best layout for the nozzles on the roof. The collaboration between artist and engineer is something that Nakaya is modest about: “My contribution to the collaboration was very simple. I kept saying I wanted ample fog for the pavilion [...] This was not a case of collaboration where art uses technology or vice versa. Rather, it was a situation where technology gives courage to the artist to go on and be completely free” (Nakaya, 1972, pp. 222-223). Both Nakaya and Mee were to become advisors for *Blur Building*, which took the size of the cloud to a different scale.





## 4.6 Institut du Monde Arabe: South Facade (1987)

Towards the end of the 1970s, the French government began to recognise the need for a secular initiative to improve the representation of the Arab world in France. This led to the creation of the Institut du Monde Arabe (IMA), the Arab World Institute, in 1980. The IMA is a collaboration between France and members of the Arab League and aims to bring together Arab and Western culture through cultural projects. Financially, France is the main funder of the institute and Arab League member states contribute to it intermittently (Institut du Monde Arabe, 2016). President François Mitterrand decided to include the IMA in his *Grand Projects* programme and a site for the erection of a cultural centre was selected in central Paris, on the Seine and bordering on the Jussieu Campus of the Pierre and Marie Curie University. After a competition, a team of architects was commissioned in 1982 to design the project. The team consisted of Jean Nouvel, Gilbert Lézénès, Pierre Soria and Architecture Studio (Martin Robain, Rodo Tisnado, Jean-François Bonne, Jean-François Galmiche). The building was completed in 1987 and has become an archetypical Western cultural centre that houses an exhibition area, a library, an auditorium, a restaurant, offices and meeting rooms, amongst other things (Morgan, 1998). However, the building prominently references traditional Arab architecture.

### Appearance

The building is executed as a single volume, U-shaped in plan with a northern and southern leg. The northern leg houses the IMA's museum, the southern leg its library. The outer facade on the northern leg is curved, following the Quai Saint-Bernard along the Seine. This side has been described as a mirror of Western culture (cf. Morgan, 1998, p. 100), that literally reflects the city (mostly Île Saint-Louis) in the curtain-wall glass structure. Up-close, external horizontal louvres at a dense spacing give this facade a fairly closed character.

On the other hand, the southern leg of the building is wrapped in floor-height square glass panels without external shading. Towards the inside of the U-shape, the facade is transparent, making visible the library floors, and the spiralling book tower that could be read as a nod to the minaret of the Great Mosque of Samarra in Iraq. The glass panels facing the Place Institut du Monde Arabe, at 225°, in a southwest direction, are exposed directly to the afternoon sun. Here, an intricate mechanised *mashrabiya* is integrated in the glass facade, filtering the light and providing privacy for the spaces adjoining the facade.

The *mashrabiya* (مَشْرَبِيَّة) is a traditional element in Arab architecture. It is an ornamental latticework that was originally used for cooling water, as it would block direct sunlight and let wind through. Over time, the screens became veils, providing

#### 4.65 Institut du Monde Arabe. Southern facade.

privacy for those behind it. The kinetic system installed in the facade of IMA is a contemporary take on the traditional mashrabiya. A giant screen covers most of the south facade: 240 identical units, 10 units high  $\times$  24 units wide, are installed in each square glass panel. All of those units feature a series of adjustable diaphragms that control the amount of incoming daylight.

Although there were clear cultural and aesthetic drivers for the design of the facade, the political context in which it was conceived required the building to be an example of energy efficiency. The southern facade sees most of the direct sunlight. In order to reduce the cooling load of the adjoining spaces, particularly in summer, the mashrabiya was supposed to partially block the sunlight. Collected heat in the double-skin could be used in winter to heat the building. Calculations and simulations during the design phase have led to the use of anodised aluminium for the shutters over stainless steel, as initially proposed, in order to avoid overheating. Also, the rate of opacity has been brought down as a function of these technical assessments. In its final form, the facade is 10% open when the shutters are closed and 26% open when the shutters are completely open. During the design phase, it was further intended that the moving facade would be a reflection of the sky, opening and closing as clouds passed by. Due to budget cuts, however, the control system for this responsive system was removed and replaced with a modest light sensor on the roof of the building that would adjust the entire facade only once per hour (Wannous, 2013).

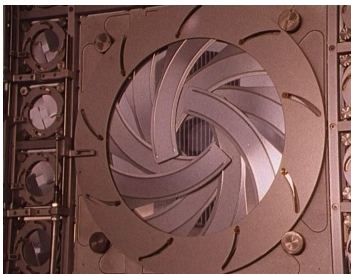
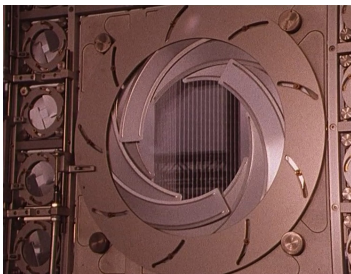
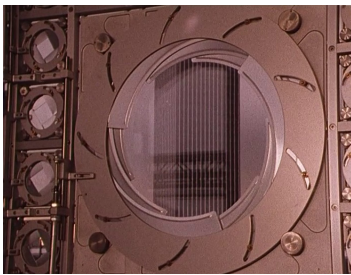
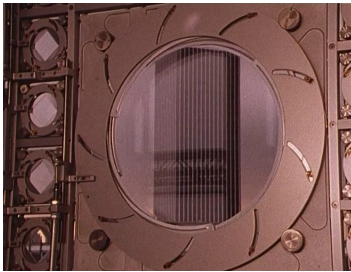

4.66 Central diaphragm closing.

### Moving Parts

The units (figure 4.67) are set in a steel frame that fits between two layers of glass, and support 73 diaphragms, of which 57 are adjustable. There are five types of diaphragm, all set in a square subdivision of the frame. The largest diaphragm is positioned in the centre and consists of nine curved blades. Around the outside are 16 smaller diaphragms that each have six blades, forming hexagons. The smallest diaphragm types are octagons and squares. 20 square diaphragms are positioned around the large diaphragm in the centre, and in a second ring around that are 20 octagons, leaving space on the two sides for the actuators. Another 16 static octagons are in the corners. The dynamic diaphragms have a control ring that is kept in place at four corners by rotary bearings. Spiral slotted holes guide the diaphragm's blades inwards or outwards upon rotation of the control ring. Two linear actuators, pointing downwards, connect to a total of eight rods, positioned between the diaphragms. The rods slide along their axes, either horizontally or vertically. The diaphragms are connected to these rods sideways, through a bracket with a slotted hole. A pin on the control ring fits the hole, so that the ring rotates when the rods are sliding.

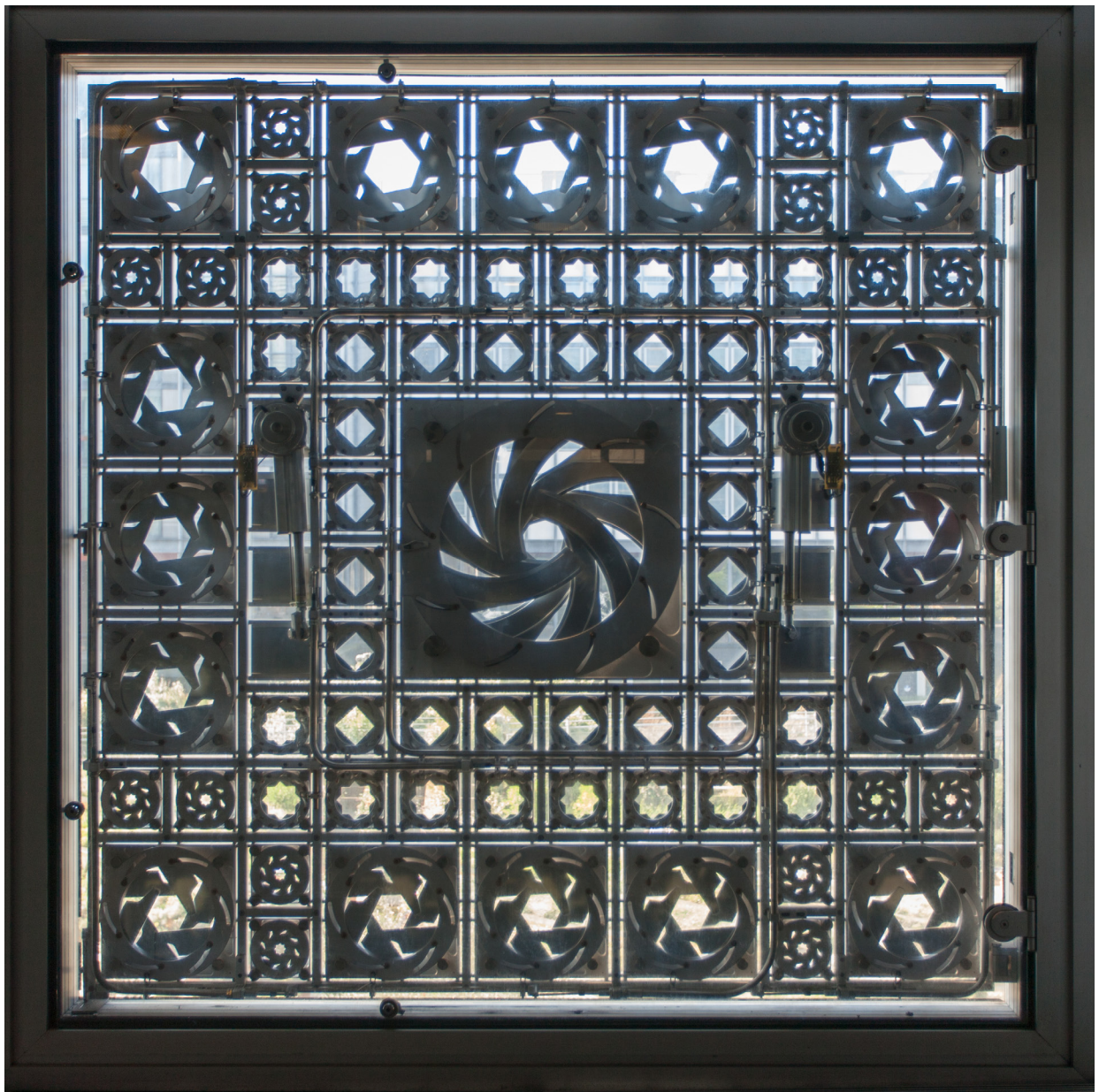

4.67 Institut du Monde Arabe. Single facade unit.

4.68 Institut du Monde Arabe. Geometric design study for the facade.

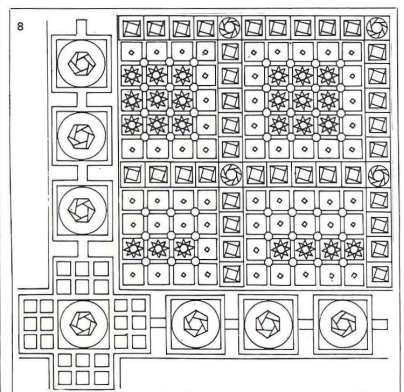
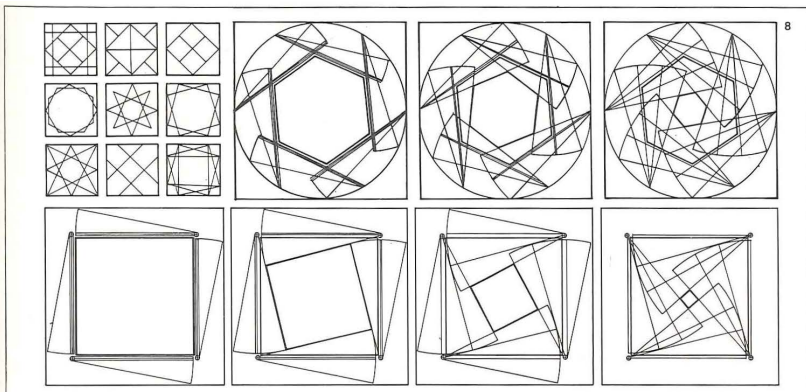

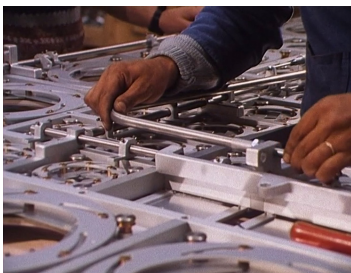
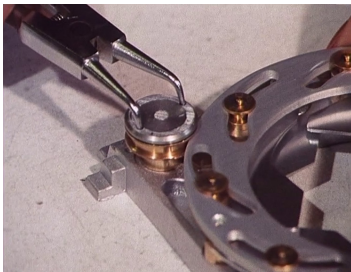
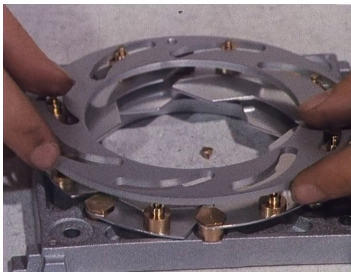
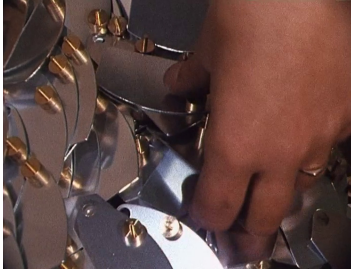
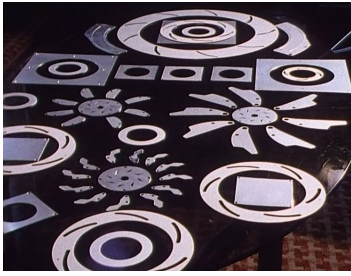

## Production

After early prototypes of the facade panels had been made, production was started under direction of GCEE Alsthom (now Alstom) in Grenoble. 240 panels, each with 345 moving diaphragm petals, and more movable parts to drive and support the shutter movements, were assembled for installation in the facade. A documentary film about the making of the system shows the production of the parts, the assembly of the panels, and their installation in the facade (Bony, 1987) (figure 4.69). Various parts, including the square frames for each shutter, are aluminium castings. CNC drilling machines are then seen to be used to precision drill the mounting holes for bearings and hinges. To anodise the parts, they are dipped several times in acidic baths. We also see the production of petals, punched out of sheet material, then fitted with the pins that lock them into the mechanism. From gritty workshop conditions, we then enter a clean assembly space with shiny components. The frame is filled with parts; a hand comes in the frame for scale and grabs some of the parts. The assembly seems like clockmakers' work, with tools so delicate that they are not normally associated with building construction. Once the camera pans along the storage racks, the number of components becomes overwhelming—we see thousands of shutters stacked, row after row.

The first sense of a collective movement of the 57 shutters in each panel is when a worker manually pulls a rod back and forth. At once it becomes clear what a unique piece of design this is, for an extraordinary setting, and at extraordinary scale. The visual complexity of the movements of four different types of shutters is mesmerising close up. It becomes almost unfathomable for the total of 240 panels forming the facade. The film continues with a tracking shot of finished panels in testing mode, opening and closing repeatedly. After we see some panels being installed on site, a number of shots capture views of Paris' landmarks through the narrowing and dilation of the iris in the central shutter: the Zaminsky tower on the Jussieu campus, quintessential Parisian rooftops, and finally a view that captures Tour Montparnasse in one and Tour Eiffel in another.

## Malfunction

There is a twist to this story that has become a cautionary tale in schools of architecture and engineering, and especially in the practice of kinetic architectural engineering. After a relatively short time in operation, panels stopped working and the system was taken out of operation. Without the excitement of the sophisticated system moving, the mechanism became more akin to an insect taxidermy. The beauty of the machinery remained undisputed, but was frozen in time and unanimated, behind glass, with the signs of death visible upon close inspection.

When I visited the IMA in September 2016 the renovation of the library and its facade had already started. I was able to access

4.69 Institut du Monde Arabe. Stages of production of the facade.



4.70 Institut du Monde Arabe.  
Structural failure of cast component.



4.71 Institut du Monde Arabe.  
Structural failure of fastening bolts.

the entire stairwell next to the main entrance and witnessed that panel after panel was broken. The damage was greater than I had imagined. Various modes of failure were visible. In some panels, cast aluminium parts were broken (figure 4.70). In others, bolts had sheared off (figure 4.71). Small piles of ground metal were visible below some of the moving parts. As the number of movements of the panels had been relatively little, it seemed unlikely that metal fatigue would have caused the failures. It is more likely that friction in the system had built up and that the actuators exerted so much force that material failure was inevitable. As the temperature between the glass panels could have risen significantly, perhaps thermal expansion played a role in the failure mechanism.

These postulations seem to be confirmed by a forensic report that was written before the renovation (Durand, 2015). The main cause of failure is identified in that report as friction in various parts of the system. Also, the significance of temperature changes is highlighted in this report.

The project has served to warn architects and engineers against overly complex building parts. The complexity makes it more likely that potential problems will go unrecognised in the design stage and will become apparent only during the lifetime of the building. It may also cause problems during maintenance. In the case of IMA, over the years, different companies had been contracted to conduct maintenance, and may not all have understood the workings of the mechanism. For example, the panels were designed to work without lubrication, but traces of lubrication were found in the panels nevertheless (Durand, 2015). This lubrication had dried out and made the problem of friction even worse.

Machines typically require different maintenance regimes than what is commonplace in buildings. Deterioration of a machine may lead to a sudden and complete end of its workings, whereas buildings tend to degrade slowly. Buildings also need maintenance, but it is often less critical for their operation. This suggests that when machines become buildings, or when buildings become machines, another standard of maintenance needs to be established for continued building operation.

## Resonance

The facade of the IMA was a precursor for many movable facades to come, however, its intricate mechanism still stands out. A notable kinetic building facade that also took the mashrabiya as a cultural and visual reference is that of the *Al-Bahr* twin towers (2013) in Abu Dhabi, UAE, by Aedas, and with Arup as consulting engineers (figure 4.73). The external facade is wrapped around the tower, consisting of triangular units organised in a hexagonal pattern. The facade leaves a gap open on the northern side of the towers that does not see direct sunlight. Like an origami structure, folded along a hexagonal pattern, the facade closes itself by unfolding to ward off the sun. A single linear actuator in the centre of each triangular unit retracts to flatten, and extends to fold six triangular

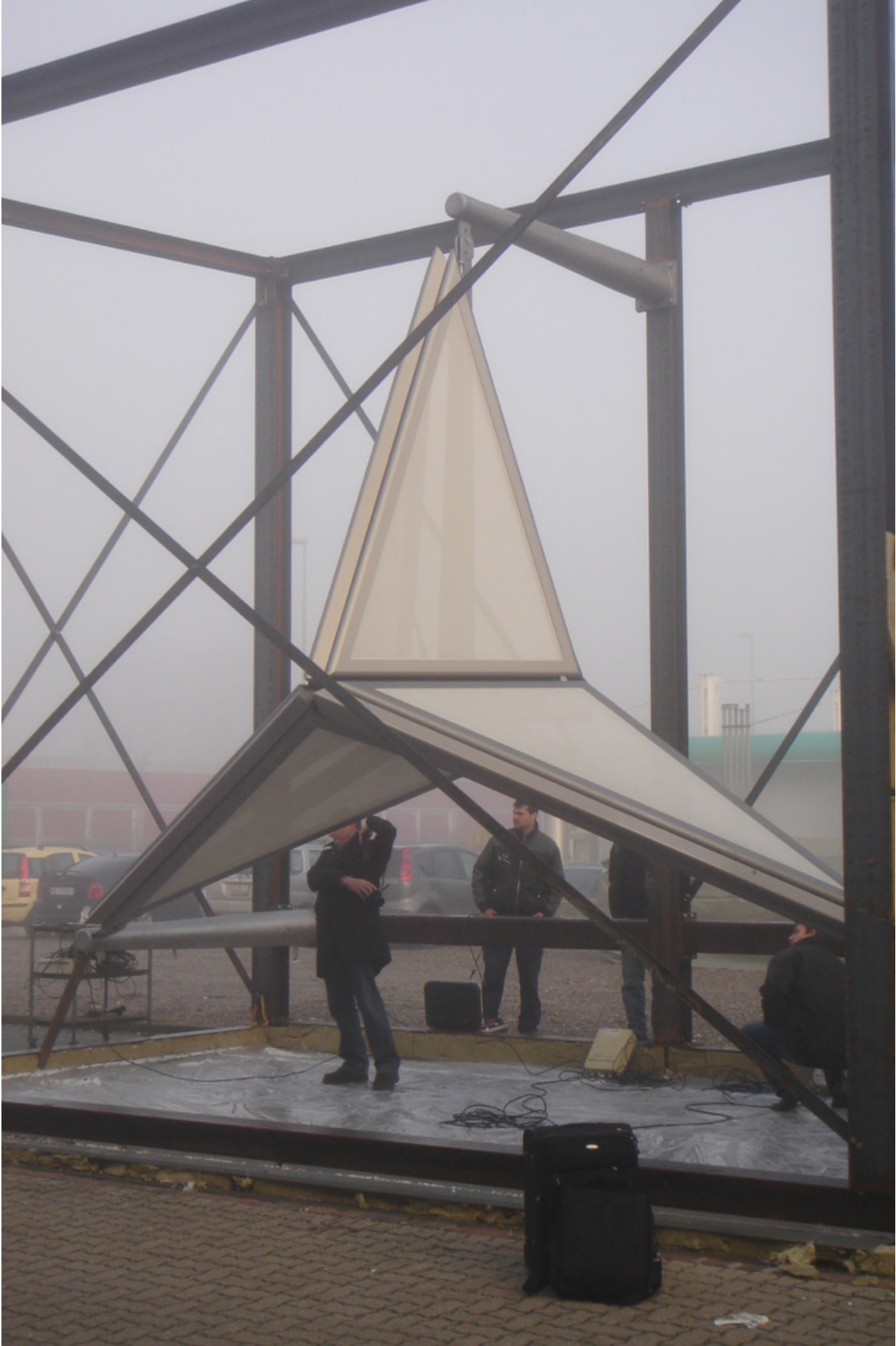



4.72 Aedas, Al-Bahr Towers. Testing of facade elements at Peter Tschudin AG in Sissach, Switzerland.

sub-panels, profiling the facade in those areas where it is open. A leading argument justifying the expense of the facade has been the reduction in energy to cool the building (Oborn, Heathcote, Denison, & Ormsby, 2013). The testing of the movable elements was performed in a purpose-built climate chamber, with sand and dust from Abu Dhabi sprayed on the mechanism to simulate the environmental conditions of the desert (Armstrong et al., 2013).

The similarities between the facades probably stop at the underlying cultural reference, but it is in the differences that the later structure could be said to be influenced by the earlier. For IMA, all 240 facade units were produced as copies, but they were highly complex assemblies. For Al-Bahr, the 1049 units of each tower vary depending on their position on the tower, resulting in 22 variations. Their complexity on the other hand is low. The production of units with varying dimensions is more manageable in a time of parametric design software and computer aided logistic control, even though a significant part of the production was executed as manual labour. The reduction of complexity of the mechanism may be understood as an approach that reduces the risk of failure. The rigorous testing of the units in conditions that approximate the scenarios expected in use (figure 4.72) can be seen as an advance in the understanding of the synergy between machines and buildings.

4.73 Aedas, Al-Bahr Towers.



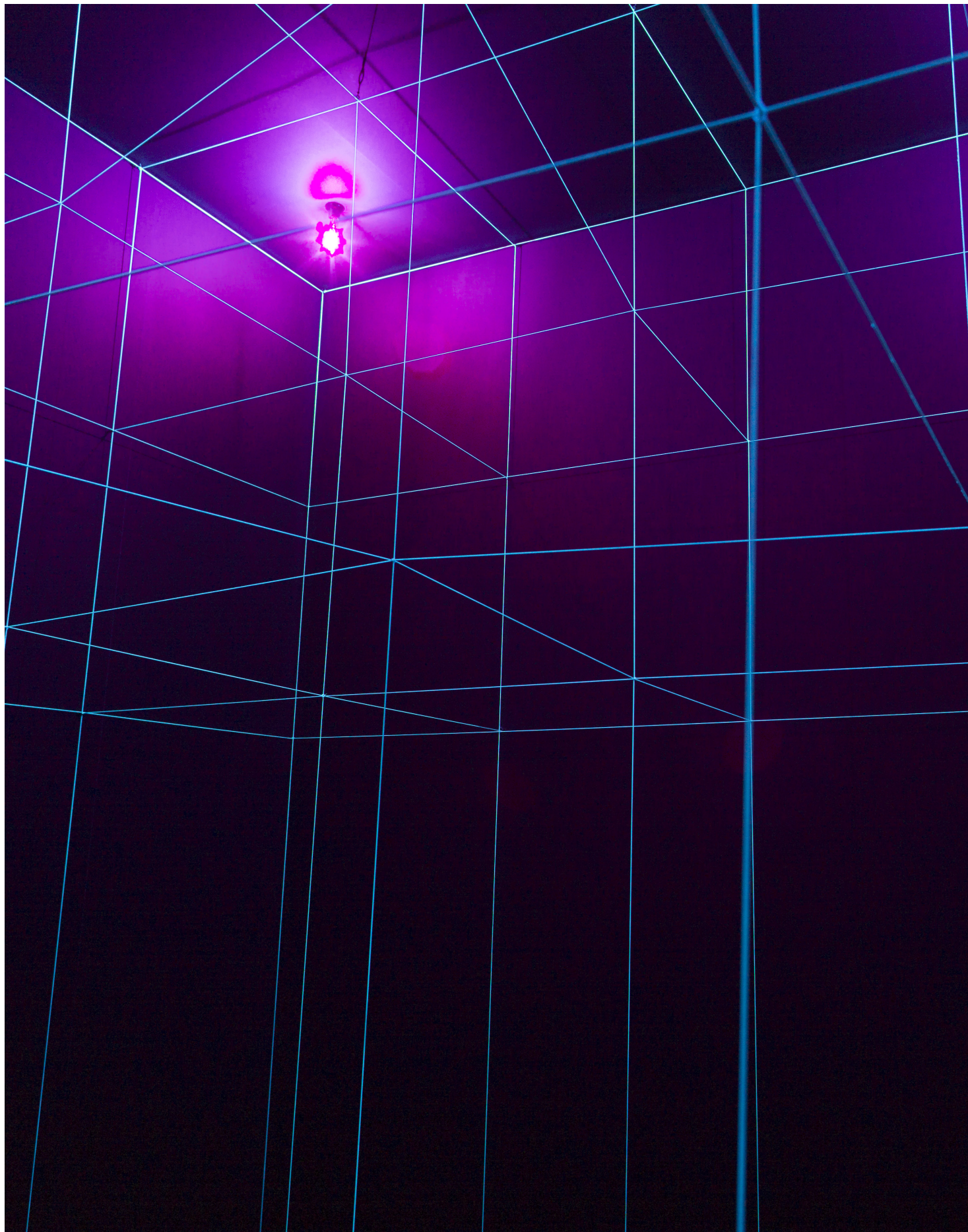

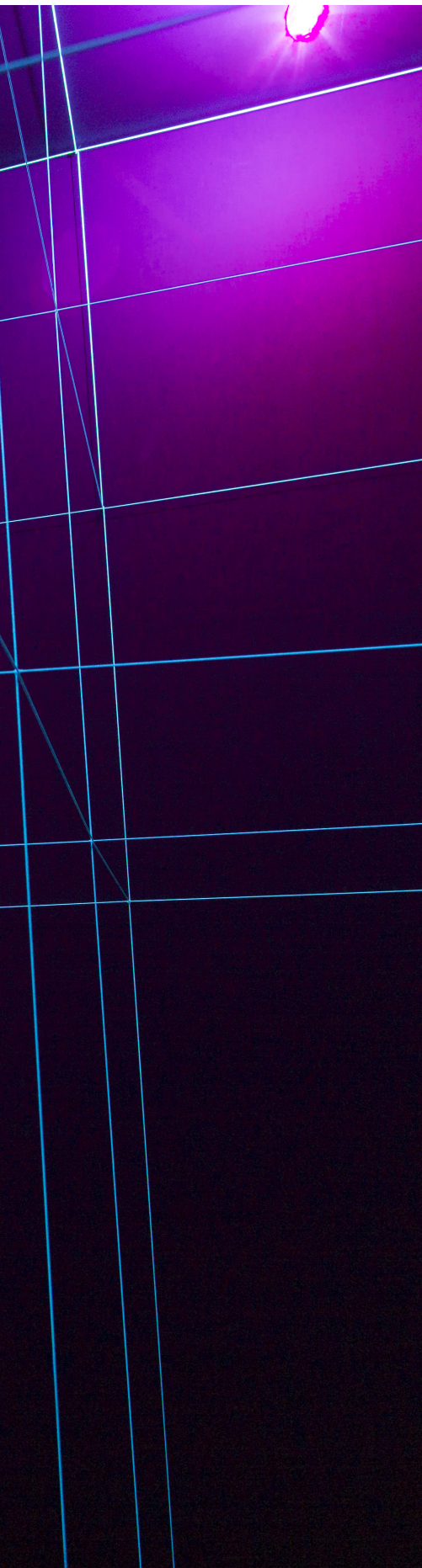

## 4.7 Spazio elastico (1959)

Around 1950, work began to emerge from artists experimenting with new understandings of perception, influenced directly or indirectly by phenomenological views of perception developed by thinkers such as psychologists Rudolf Arnheim, James J. Gibson, and philosopher Maurice Merleau-Ponty. In these views, perception is part of an embodied experience that puts emphasis on the physiology of the human body and its interaction with the environmental context. The artworks produced by artists operating in this area became inseparable from the viewer in that they often required an active way of viewing. For example, the works would be interactive, revealing themselves by observation from different positions, or appearing through visual illusions. As Matthieu Poirier writes, the ambition of those artists was to work with perception as their medium, by way of work that experimented with vision, time and space (Poirier, 2016). Apart from static work that explored optical phenomena through use of colour and pattern, for example, several visual artists that gained prominence around this time, such as Julio Le Parc and Hartmut Böhm, worked with physical movement in new sorts of kinetic paintings and sculptures.

In this context, towards the 1960s, several artist groups began forming in Europe, exhibiting work at influential exhibitions such as *Le Mouvement* in Paris, 1955, *Bewogen Beweging* in Amsterdam, 1961, *Arte Programmata* in Milan, 1962, and *The Responsive Eye* in New York, 1965. One of these groups, Gruppo T, was formed in 1959 at the Accademia di Belle Arti in Brera, a central district of Milan. The group members were Giovanni Anceschi, Davide Boriani, Gabriele Devecchi, Gianni Colombo, and later Grazia Varisco. The *T* in the name stood for *tempo* (time) because the aim of their collective works was to be variable, irreversible and to be perceived as visually changing with time. Bruno Munari and Umberto Eco described their work as *programmed art* that was structured and instructed by their authors but that allowed for unpredictability in its expressions. Starting in 1960, the group organised a series of exhibitions of its own collective and individual work. These exhibitions were called *Mirrorama*, and were numbered sequentially to imply a progression in the collective development of the group (Pola & Scotini, 2015).

Gianni Colombo, who was born in 1937, was one of the protagonists of Gruppo T, until 1968, when he and Grazia Varisco distanced themselves from the group. From 1962, he would also be part of the international movement *New Tendencies*. Francesca Pola describes two related aspects in the work of Colombo that made it unique. The first was a new vision on the artwork that would investigate and demonstrate relations between body, mind and space. The second was the creation of immersive spaces that would estrange the viewer and provoke unusual reflection, reaction and behaviour. “In both cases, the artist’s goal was the same: to create objects and environments that were instruments for a progressive emancipation from our conventions of relationship with the world, making us think through the body” (Pola & Scotini, 2015, p. 14).

## Immersion

At Gruppo T's first group exhibition, *Miriorama 1* (1959), Colombo showed a number of reliefs; rubber surfaces that the viewer could interact with like pressing keys on a keyboard (Ehrmann, 1975). *Miriorama 4*, in 1960, was his first solo exhibition at Galleria Pater in Milan, where he showed *Superfici in variazione* (*Surfaces in Variation*), *Rilievi intermutabili* (*Intermutable Reliefs*) and *Strutturazione pulsanti* (*Pulsating Structuralisations*), all works from 1959. Note that many of the works were produced as variations, therefore multiple versions exist. Where Colombo's early works required some manual input to create movement, and to establish a connection with the viewer, in the *Strutturazione pulsanti* series, the movement became automated (figure 4.75). A grid of polystyrene blocks, set in a wooden frame, would gently throb out of the plane, creating a subtle wave across the surface. The individual blocks were moving forwards and rotating slightly, creating gaps between the blocks and closing them. Now, not through direct physical interaction, but through automated movement of the blocks, the work enabled a connection with the viewer. Colombo is quoted as saying:

**I think that only in change does an object show its true appearance and highlight its character by emerging from the uniformity of the space that surrounds it; indeed, it is through the passage of time that we experience reality. The same elusiveness of the successive phases of a phenomenon is a constitutive part of the reality that cannot express its fullness in static formal symbols. (Pola & Scotini, 2015, p. 30)**

4.75 Gianni Colombo, *Strutturazione pulsante*.

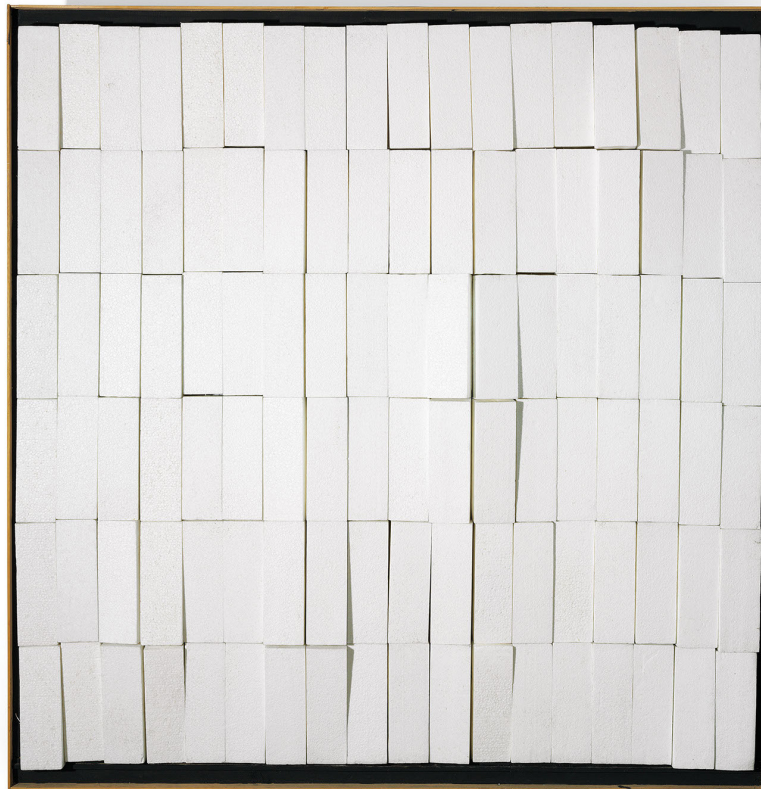



4.76 Gianni Colombo, *Strutturazione pulsante*. Mechanism behind installation.

Concealed at the back (figure 4.76) of *Strutturazione pulsanti*, a motor would drive various horizontal axles through individual belts. Wheels were mounted on each axle with brackets, in a staggered fashion so that upon rotation of an axle, wheels would in turn push against the back of the blocks that were bound together by patches of fabric, glue and wire. Because of different radii of the belt-driven pulleys, all axles would rotate at different speeds, and the observed pulsation would appear rhythmic, but somehow natural and not mechanical (“Museo del Novecento - restauratori e restauri in museo,” 2014).

Until 1964, Colombo’s production remained confined to the scale of objects. Some works, like the *Strutturazione pulsanti*, were like kinetic paintings in their relative dimensions, their display on a wall, and their framing. But the absolute dimensions became such that some of the works practically could have been walls. Colombo writes about *Strutturazione pulsanti*:

**I created this object at a sufficiently large scale (4,000 cm<sup>2</sup>— and envisioning even larger dimensions), thus tending to overflow the boundaries of the visual field of the viewer, for the purpose of escaping the dimensions that usually force on the object a vaguely totemic role or the role of a model for problems or hypotheses to be demonstrated. (Pola & Scotini, 2015, p. 26)**

Pursuing more immersive experiences, Colombo would explore in further work how flashes of light created afterimages in the observer’s eyes, imprinting layers of temporary states of kinetic structures. Ultimately, however, these images would freeze the movement in a sequence of conditions, as *kinetic frescoes* in the words of Colombo. In order to fully immerse the observer, he

realised that his work had to address more senses than just the visual.

### Appearance

In 1967, he presented *Spazio elastico* (Elastic Space) in Graz at the *Trigon 67* exhibition. A dark space was fitted with a three-dimensional orthogonal grid of elastic fluorescent threads. By pulling the threads in different directions, the matrix of the space would slowly transform, creating a sense of deformation of the space itself. This first instantiation of the *Spazio elastico* series also had an uneven floor, to address the sense of balance of the observers, and flashing lights would cause afterimages. In later versions, the uneven floor and the flashes were removed.

*Spazio elastico* has proved to be one of Colombo's most successful and lasting works, measured by the award it won at the Venice biennale of 1968 and by recent displays of the work at multiple exhibitions. The version I have witnessed was exhibited at Louisiana museum of modern art in Humlebæk, Denmark, as part

4.77 Spazio elastico. Drawing with four actuators.

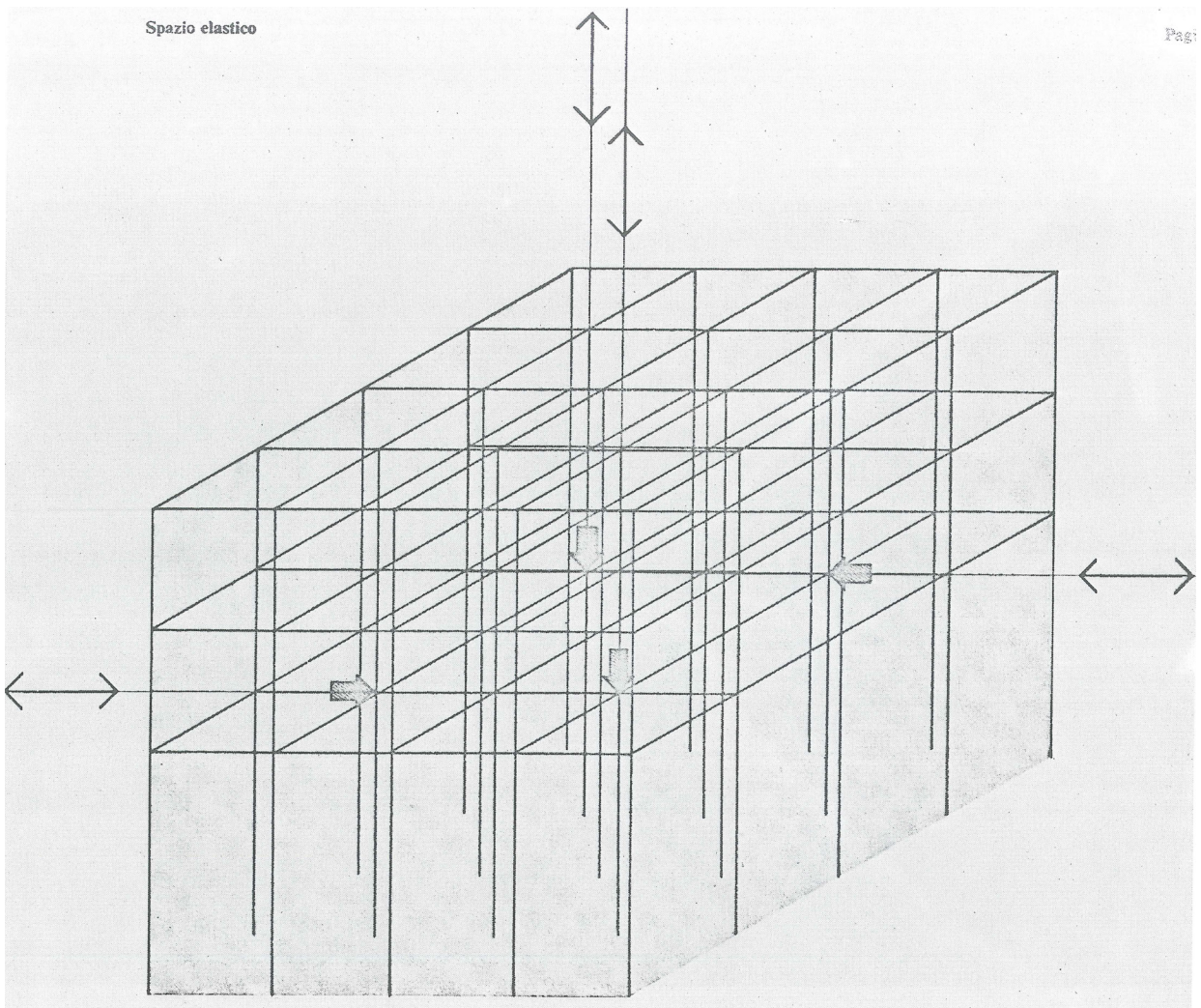

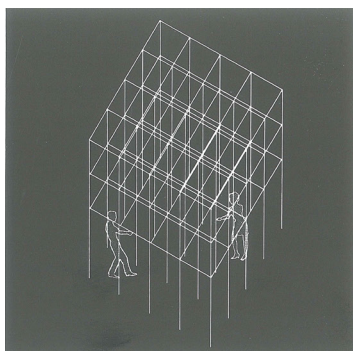
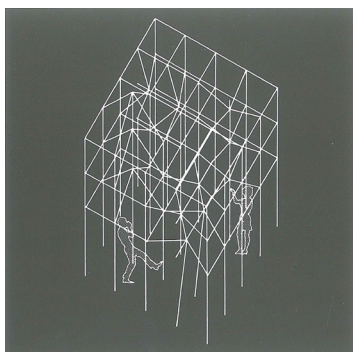

4.78 Spazio elastico. Drawing.



4.79 Spazio elastico. Gianni Colombo.

of the *Eye Attack* exhibition in 2016. The visitor enters a purpose-built box with inside dimensions of  $4 \times 4 \times 4$  m. The space is dark, the walls, floor and ceiling are black. Research in the 1950s had shown that light had a range of psychological effects, therefore the state of darkness was a deliberate artistic choice by Colombo in order to achieve absolute expressive neutrality and a state of maximum emotional concentration (Pola & Scotini, 2015).

## Moving Parts

A grid of elastic threads structures the space. At 1 m spacing, 25 vertical threads span floor to ceiling, with threads also positioned along the walls. Horizontal threads are omitted at floor level and at 1-m height to allow visitors to roam the space more freely, thus leaving 15 in one and 15 in the perpendicular horizontal direction. Four UV lamps are positioned in the corners at ceiling level, highlighting the fluorescent threads. Not visible to the visitor are three motors outside the cube, that repeatedly pull in and release one vertical and two horizontal threads. Construction drawings show that in early versions of the three-dimensional *Spazio elastico* environment, four motors had been present, pulling two vertical threads (Pola & Scotini, 2015, p. 178). Both Louisiana Museum and Van Abbemuseum in Eindhoven, Netherlands, where the installation was shown in 2016, confirmed that only one vertical thread had been actuated (Tine Colstrup, personal communication, October 2017 and Willem Jan Renders, personal communication, May 2018).

The motors on the outside of the box had a lever, thus their rotating action would result in a cyclic pulling and relaxing of the elastic thread (Stefano Boccalini, personal communication, May 2018). Small deformations become quickly visible due to the rectilinearity of the relaxed grid. Because all the nodes are interconnected, pulling one thread causes an elastic deformation of the whole grid that is most immediate around the thread that is pulled, and becomes less pronounced further away. Stretching three threads simultaneously therefore causes three-dimensional effects that cannot be easily attributed by the observer to a single movement. Other movements of the grid occur when visitors stretch the threads manually, something that has gotten more emphasis in later variations in the series that were executed as smaller-scale two-dimensional objects (figure 4.81).

## Movement

My experience of the work was in the context of the exhibition at Louisiana museum, with many kinetic works around it. In anticipation of dramatic movement, the slow and sparse motions in the work were at first sight slightly underwhelming. This was perhaps also a side-effect of the fluorescent light, that is meant to emphasise the threads. The light however would also highlight

other visitors, whose movements were more pronounced, distracting from the work itself.

The orthogonal grid is the archetypical representation of three-dimensional space. Seeing that grid distort implies a distortion of the space. However, concentration was required to see beyond the threads moving as objects in the space. The work seems to demand a certain adjustment to the sensibility of its movement in order to appreciate the movement of space itself. Having a perspective so close to the grid, inside the grid, at times made it seem impossible to take in all the movement simultaneously and to maintain a calibrated sense of rectilinearity, especially in three dimensions. The relaxed state of the work would therefore be replaced with the dynamic state as the new baseline, never knowing where the work is precisely, just that it is moving.

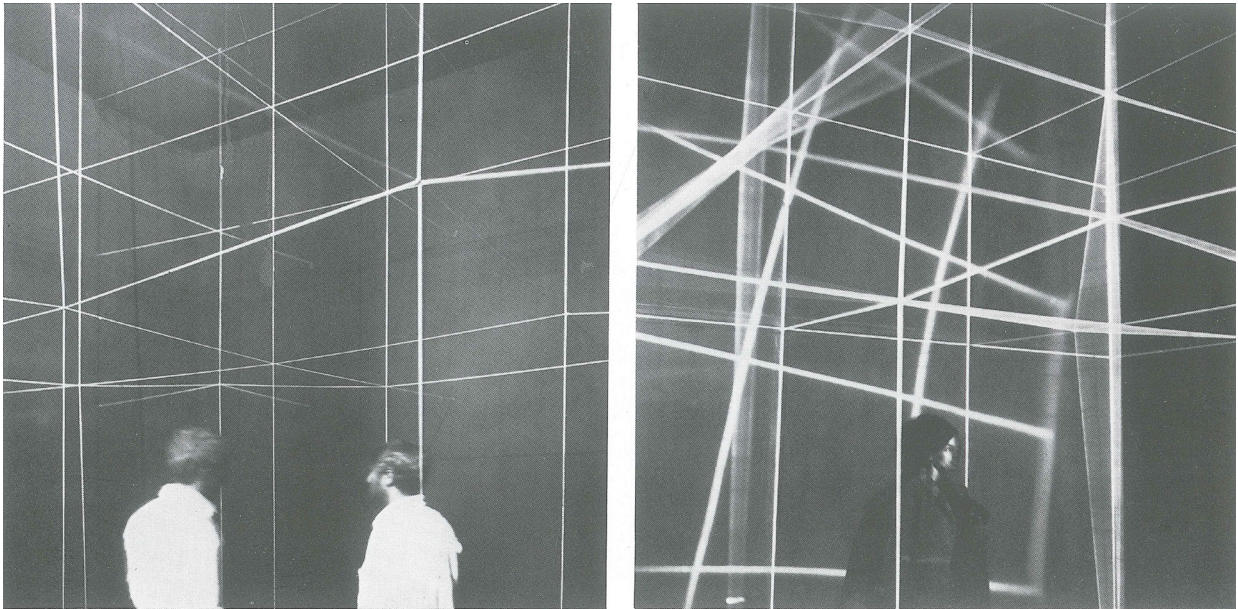

4.80 Spazio elastico.



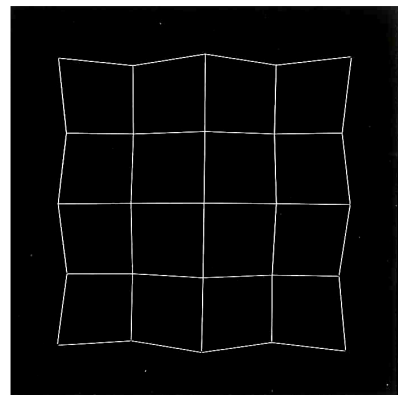
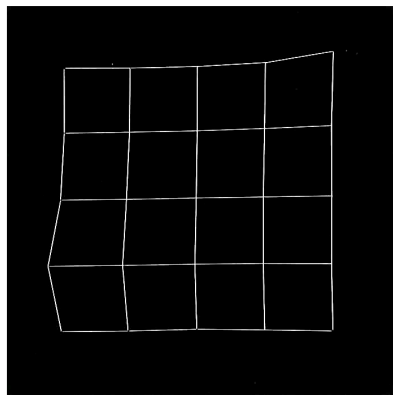
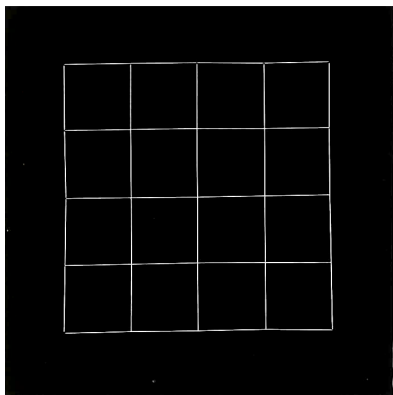
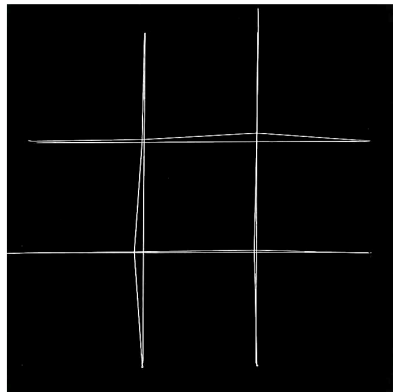
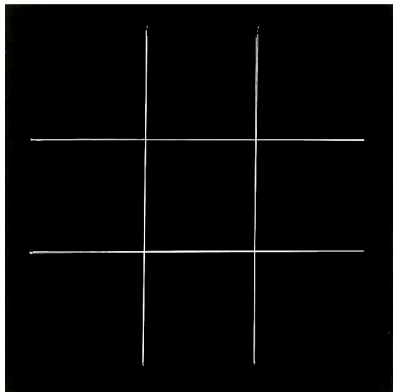
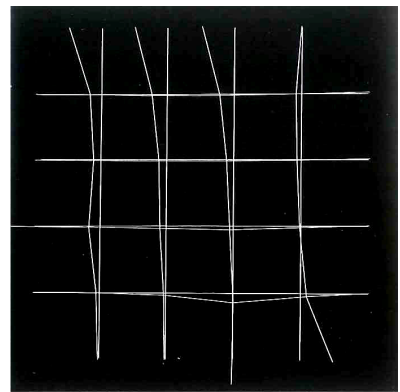
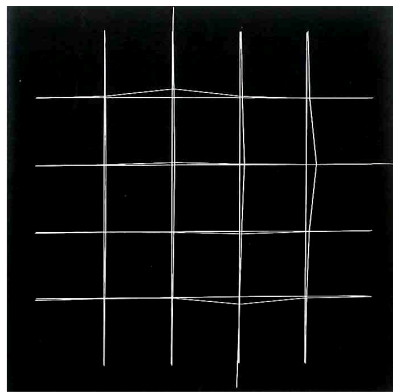
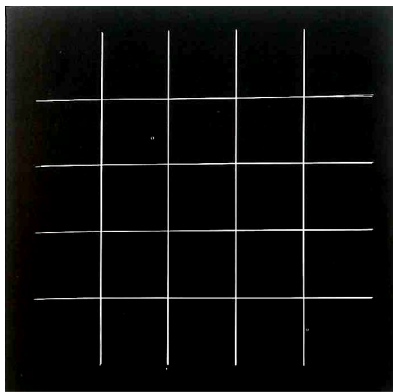

4.81 Spazio elastico. Smaller, two-dimensional configurations.



## 4.8 RV (Room Vehicle) House Prototype (2012)

Le Corbusier was famous for writing that “[I]a maison est une machine à habiter” (Le Corbusier, 1924, p. 83). In a chapter adorned with images of high-tech airplanes, including the nine-wing Caproni Ca.60 Transaereo, he argues that the reason aviation had developed so successfully in such a short time is that the problem that needed to be solved had been stated well. The resulting machine served its purpose efficiently. Buildings, to the contrary, were held back in their development because architects were looking at the past, rather than the future. Considering the house as a machine meant answering a well-stated question about the core of what the building was supposed to do: providing shelter and affording the undertaking of daily tasks such as cooking, washing and sleeping. The building would serve its purpose efficiently.

### Buildings as Machines

The iconoclastic text and the architectural output that followed have given rise to a new set of icons of modernism, devoid of ornamentation, that fostered a style where form follows function. Some have pursued in their work a particular machine aesthetic, in search of what Robert McCarter called “more original relationships between man and technology” and “a more original conception of the nature of technology itself” (McCarter, 1987, p. 12). In the exhibition *Building: Machines* at P.S.1 Contemporary Art Center in 1986, the work of Neil Denari, Ken Kaplan, Ted Krueger, Chris Scholz, Peter Pfau and Wes Jones showed visions of furniture and buildings that explored the conditions of buildings as machines, mostly adopting a visual similarity to more and less high-tech machinery of the time.

The image of buildings as machines has become more pertinent with the inclusion of ever more technologically advanced equipment in today’s world considered to be part of the building. Air handling units and the ducts that transport fresh and used air through modern office buildings take up a significant amount of space and require careful coordination between designers of those systems and those who design its structure and finishes. Advances in vertical transport have enabled the development of ever-higher buildings. In projects such as the *Lloyds Building* (1986) in London by Richard Rogers, or the *Pompidou Centre* (1977) in Paris with Renzo Piano, these technologies are celebrated by making them highly visible. Today buildings are not just machines that answer a single clearly stated question, they deal with many questions at the same time.

## Buildings as Robots

An increased amount of autonomy in dealing with these questions led to the comparison of buildings with robots. In his introduction to robotics, professor Alan Winfield defines a robot as “1. an artificial device that can sense its environment and purposefully act on or in that environment; 2. an embodied artificial intelligence; or 3. a machine that can autonomously carry out useful work” (Winfield, 2012, p. 8). Professor Maja Mataric defines a robot as “an autonomous system which exists in the physical world, can sense its environment, and can act on it to achieve some goals” (Mataric, 2007, p. 2). Both stress the role of autonomy and some sense of environment that the robot acts in. There should be little doubt that these definitions apply to many contemporary buildings. In fact, Steven Groák writes in 1992 that “buildings have been moving towards the status of robots for some time” (Groák, 1992, p. 115). An example to illustrate this is the modern greenhouse that optimises internal climate conditions and energy use by automatically ventilating the space with outside air. The building senses the conditions of its direct environment, and its control systems interpret atmospheric data from nearby measuring stations and weather predictions to proactively open or close the vents (e.g., Castilla, 2013).

Another example is the type of building that protects optical telescopes, like the enclosure for the *European Extremely Large Telescope* (figure 4.83) that is under construction on Cerro Armazones in Chile. To avoid temperature differentials that would distort the structure and the mirror of the telescope, the enclosure keeps the structure cool during daytime when outside temperatures rise. The temperature inside is gradually set to match what is projected outside at the time of opening the observing slit in the evening. During the hours of darkness when the telescope operates, the enclosure dome rotates on its foundation to track the

**4.83** European Extremely Large Telescope (E-ELT).

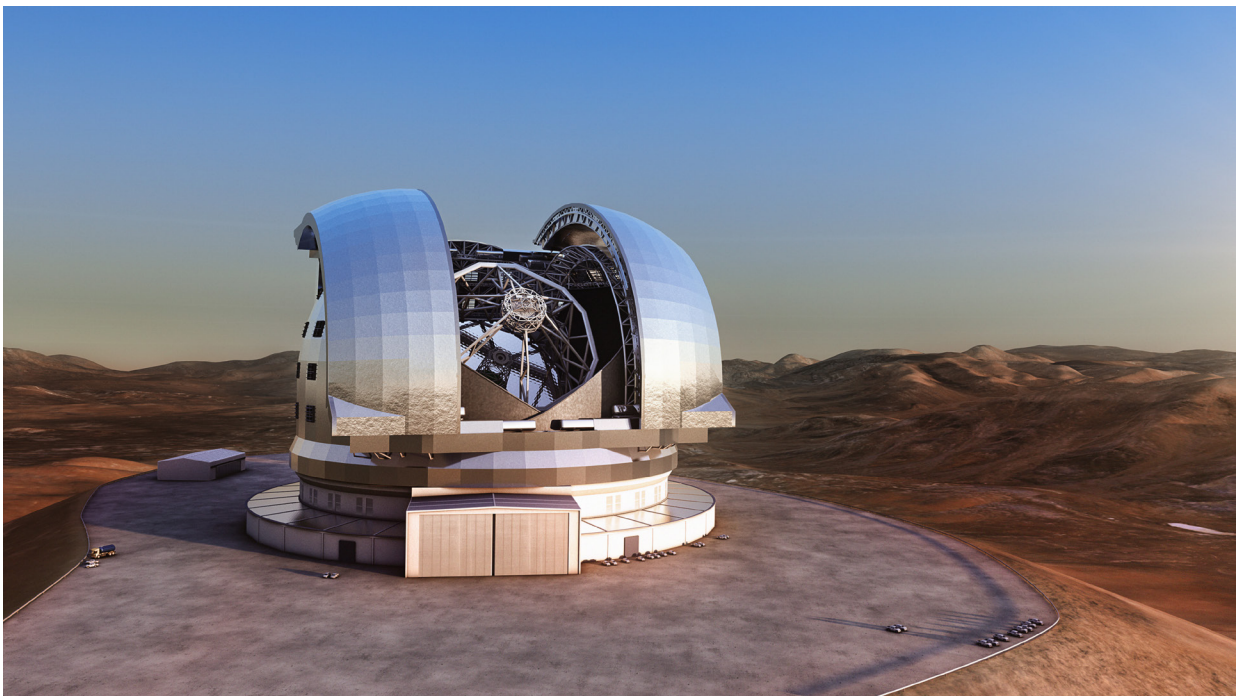

movements of the telescope and align the observing slit with the azimuth angle of the mirror. The enclosure also controls the airflow across the mirror by operating a windshield and an array of louvres distributed around the dome. These operations are informed by sensor readings. Not only does this building act autonomously to serve a particular function, it is highly mechanised and features many movable parts, which allow it to act in different ways. The accuracy of the enclosure operations, add to the apparent parallels with robotic autonomy and the illustrative value of this example is further bolstered by the absence of people anywhere near the building during operation (although of course it could be entirely remote controlled). However, its principles are used in many other buildings of a more mundane character.

Academically, buildings as robots have been interpreted in different ways and are part of various areas of research. For example, architect and educator Michael Fox uses the term *robotecture* to describe his collective teaching and design activities with kinetic interactive architecture (Fox, n.d.). The compendium he wrote with Miles Kemp (Fox, 2016) about interactive architecture draws on work in *intelligent environments*, *human-computer interaction*, *ubiquitous computing*, *kinetic architecture*, *cybernetics* and *artificial intelligence*.

Professor of architecture Henriette Bier captures both the robotic production of architecture and “physically built robotically augmented environments” in *Robotic Building* (Bier, 2016; Bier & Mostafavi, 2016). As part of the Hyperbody group and its history with agent-based approaches, Bier describes a decentralised, multi-agent and real-time approach for robotic buildings that is *interoperable*, meaning it includes people, robots and production facilities.

*Towards a Robotic Architecture* is a collection of essays edited by Mahesh Daas and Andrew John Wit (2018). Although the introductory chapter sets out a framework for robotic architecture that includes *robotic space*, most chapters predominantly interpret robotics as tools for fabrication. Notable exceptions are the texts describing *Infundibuliforms* (2016), a project by Wes McGee, Kathy Velikov, Geoffrey Thün, and Dan Tish; and Philip Beesley’s intricate living-robotic systems. Besides performing like robotic systems, both of these structures are also produced largely using robotic technologies (Beesley, 2018; McGee, Velikov, Thün, & Tish, 2018).

Professor Keith Evan Green has argued for a research field of *architectural robotics*, first with Mark Gross (Gross & Green, 2012) and, in a more recent publication, defines the field by setting out what architectural robotics is not:

**It's not human-robot interaction with its fixation with humanoids, mostly proprietary ones, programmed to serve people. It's not intelligent buildings, focussed on temperature control and the opening and closing of windows and shading devices. It's not intelligent environments, outfitted with arrays of sensors to capture the everyday activities and mishaps of their inhabitants. It's not digital fabrication with robots - industrial robots programmed to manufacture buildings and their components. It's not buildings with mechanically moving parts, where walls, floors, roofs, and maybe entire rooms are repositioned. And it's not human-computer interaction in its most persistent form: still caught up in the screen. (Green, 2016, p. 173)**

The field is characterised as a triangulation of computer, human, and environment. The work of Green's lab includes for example the Animated Work Environment, a desk space that supports different tasks by transforming physically.

Callaghan et al. (Callaghan, Clarke, Pounds-Cornish, & Sharples, 2000) describe what they call *Intelligent Buildings* as robots and even go as far as modifying Le Corbusier's words into "A building is a robot we live inside". Coming from a computer science perspective, the key to intelligent buildings is a computational aspect that governs the building environment. They draw relations to the work conducted by Rodney Brooks in the 1980s and 1990s that studied the emergence of behaviour in autonomous robots through their embodied intelligence and pursued that as a model for their own experiments.

## From Digital to Robotic Movement

In a discussion at the 1995 Anywise conference in Seoul, Korea, Greg Lynn defends his particle-system design approach for a house in Long Island, New York, making use of special-effects software used in the movie industry. Architecture critic Jeff Kipnis asks Lynn:

**Let me hold you accountable to the question, Greg. Because you stay at the level of dynamic animation, we could be fascinated by what we see, but because you do not resolve it as a fixed static object with materials, structure, and construction, at which point we see its real consequences, we're left fetishizing the video rather than really understanding its design consequences. Is this true or not?**

Lynn answers:

**I want to resist answering that question. In other situations in which I have shown material like this, the response has been 'Well, are you saying architecture has to move in order for this to be an interesting design approach?' I would say no.**

To which Kipnis says:

**You say no, but you do not show us what happens when you take the motion away. (DavidsonAnyone Corporation, 1996, p. 112)**

In the essay *Animate Form* (Lynn, 1998), which is part of the eponymous publication about Lynn's work that follows three years later, he develops some of the ideas he set out during the conference. This includes his critique on the dominant state of architecture, as an *architecture of stasis*. As a counterpoint, he presents a highly dynamic design process that ultimately, however, refrains from delivering an architecture in motion. Lynn's view is then that architecture does not have to physically move in order for it to possess a similar potential. He compares this to the hull of a sailing boat that is designed in a dynamic context of competing forces, but ultimately becomes a single continuous surface that is static, while holding within its topology a certain capacity for dynamism and variations in use. Lynn seems to be put off by actual movement in buildings, suggesting that examples of kinetic architecture are often confined to a number of pre-set configurations, a limitation that is absent from virtual motion (Lynn, 1998).

In 2012, Lynn was asked to propose a project for the Future Primitives programme at the Biennale Interieur in Kortrijk, Belgium, that was held in October of the same year. The brief calls for the design of a small, 60-m<sup>2</sup> space. His response, *RV (Room Vehicle) House Prototype*, is a dwelling that actually contains about 150 m<sup>2</sup> of usable floor space, but with a much smaller footprint. By rolling the building 180 degrees (rotation around a horizontal axis), one wall and the ceiling also become activated as floor space. In descriptions of the project and through its categorisation in Lynn's portfolio, the building is to be understood as a robot (Chalcraft, 2012; Lynn, 2012). In describing the project, Lynn again uses the boat analogy, this time to refer to its entire movement when in the water: "[Y]ou live on the wall and the floor at the same time, because it moves" (Sibolboro, 2012).

In a short text on his website, Lynn seems to anticipate the obvious question: *Why move now?* He writes:

**The pressure for new types of physical experience has pulled innovation in architecture in the direction of spectacles of motion. So it is possible now, in a way it never was before, to integrate robotic movement and motion control into buildings. [...] Twenty-five years ago I decided to focus on the PHENOMENAL motion of the digital design medium while dismissing LITERAL motion. Today, literal motion and its phenomenal partner seem worth returning to. (Lynn, 2014a)**

Lynn returns to literal motion by arguing that expectations of the built environment have been influenced by contemporary digital conditions manifested in modes of communication, entertainment, and interaction with objects (Lynn, 2014b). *Room Vehicle*, he writes, is an adaptive intelligent environment that provides a form of fulfilment tailored to the specific desires of the occupant (Chalcraft, 2012). Lynn investigates this aspect of serving the occupant as a combination of car and living room. He does this

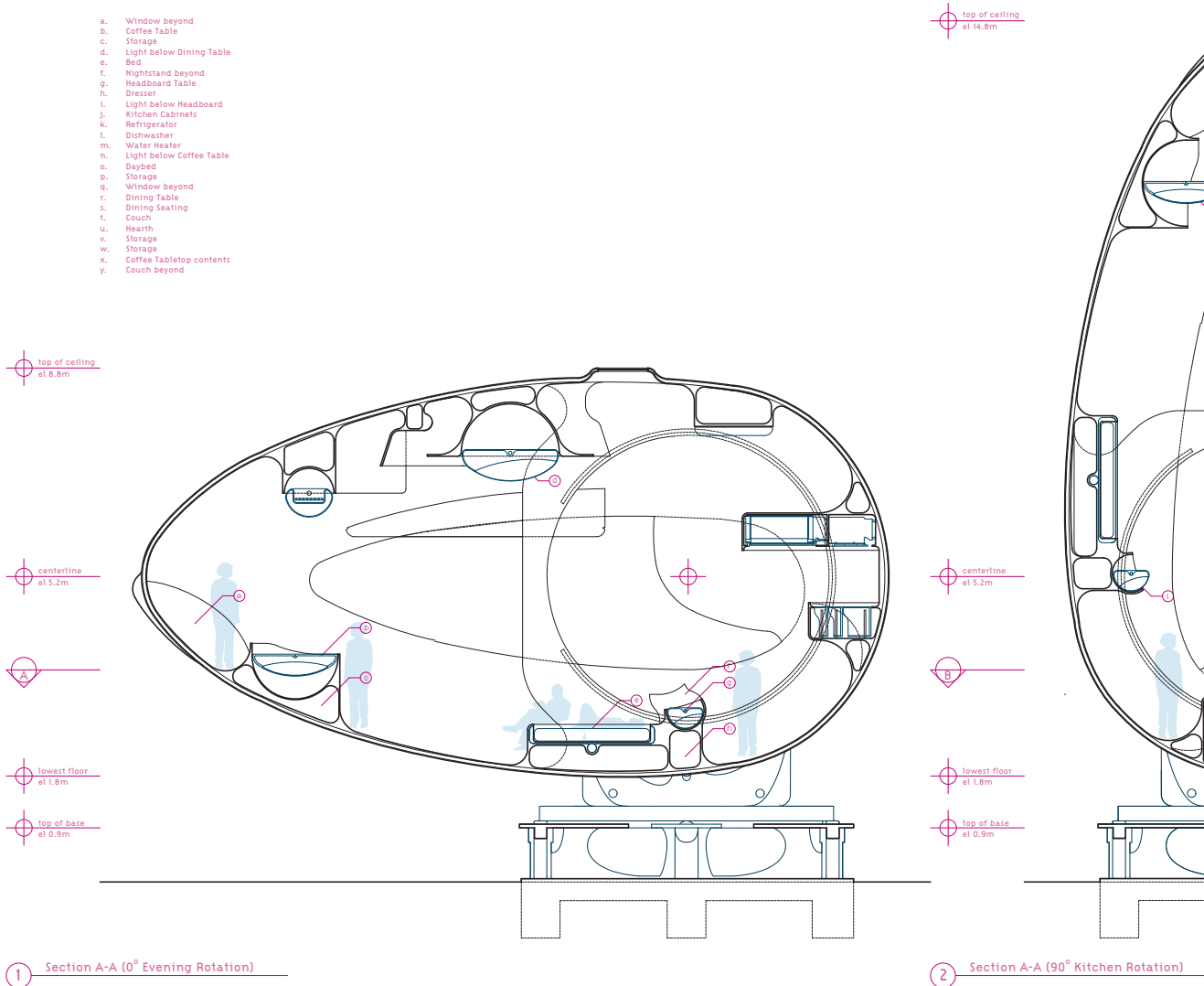

**4.84** RV (Room Vehicle) House Prototype. Drawing of three positions.

by exploring the extravagant furniture typology of the reclining chair, some of which is equipped with drinks coolers, massage functionality, and the integration of home entertainment. Such furniture alludes to the possibility that the sitter never has to leave the chair, but *Room Vehicle* is designed to have the opposite effect in bringing

the enthusiasm and activity of a theme park, a hamster ball, an exercise machine, a natural landscape or sporting equipment to the human living sphere. The living space does not move around you to make you comfortable, but instead you are rolled and must climb, tumble, traverse and spelunk across the ergonomic surface like a mountain goat, a Pilates disciple, a Parkour Tracuer or wannabe Spiderman (Lynn, 2014b).



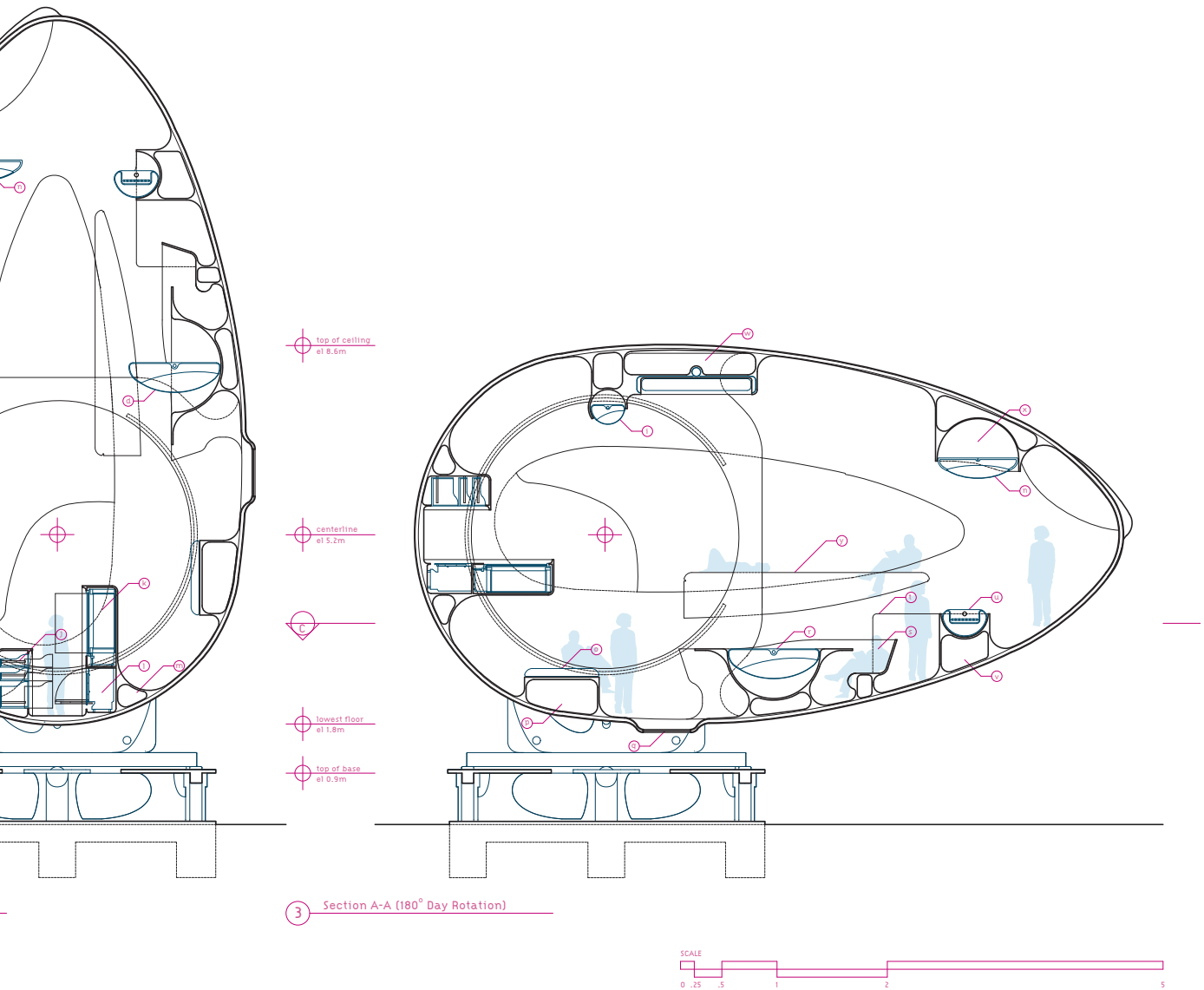

## Appearance

For this project, which remains a prototype, two working prototypes were made, at scales of 1:25 and 1:5. The material for the larger prototype is a foam core, sandwiched by a carbon fibre epoxy laminate, resulting in the entire structure weighing under 50 kg. This lightness eases the movements, and reduces the need for heavy machinery to activate the structure. The structure is set in motion through an alt-azimuth or pan-tilt mechanism that allows rotation around a horizontal and a vertical axis (figures 4.85 and 4.86).

The various aspects of a typical dwelling such as living, bathing, and sleeping are distributed through the space, and become unlocked by rotating the whole building to a specific orientation. The furniture and facilities are gimbaled as sometimes seen on a ship,

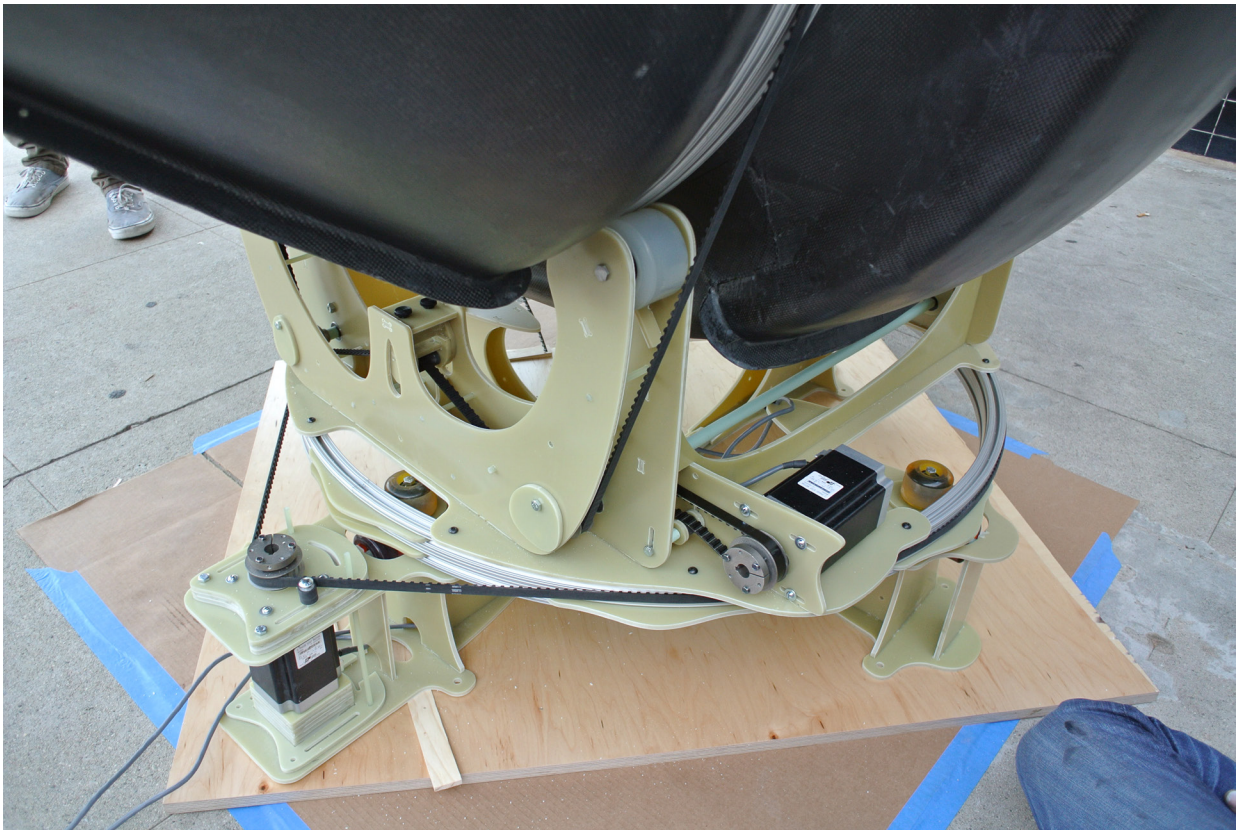

**4.85** RV (Room Vehicle) House Prototype. Drive mechanism of 1:5 scale model.

**4.86** RV (Room Vehicle) House Prototype. Drive mechanism of 1:25 scale model.

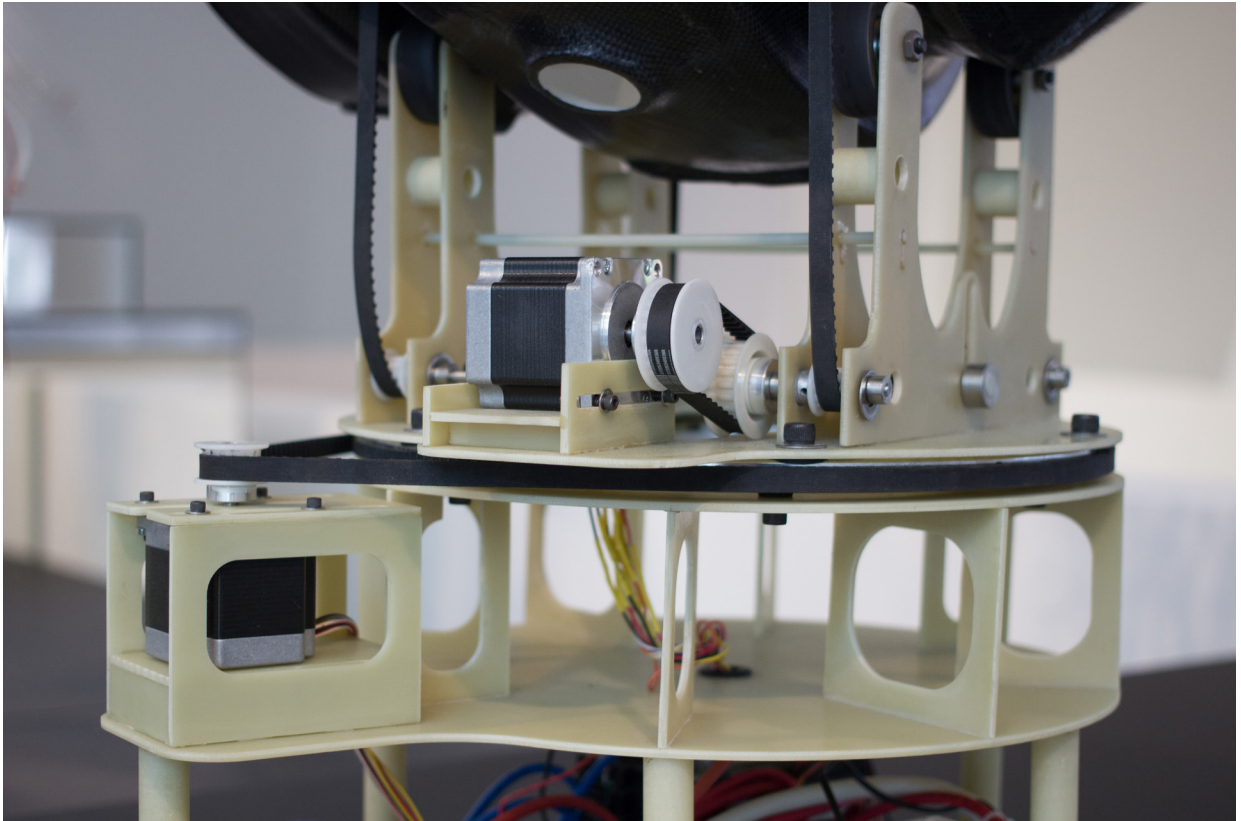

so they remain level at all times. Rotating along its horizontal axis, from one horizontal position to another, the house passes through three configurations. First, the floor is a living room, then a wet-space with kitchen and bathroom, and finally a bedroom. The idea that a floor seamlessly transforms into a wall or a ceiling has been explored in static architecture before, famously in OMA's Jussieu library project (that was never realised), in their *Educatorium* in Utrecht (1995) or in MVRDV's Villa VPRO in Hilversum (1997). Prada Transformer (2009), a temporary installation in Seoul, Korea, also OMA uses a number of discrete movements to transform walls into floors. The whole space was lifted and turned three times by mobile cranes to change the functionality of the building.

The building can further rotate around a vertical axis, allowing the users to choose to position the room to enjoy a particular view or lighting conditions, for example.

## Moving Parts

The mechanisation of *Room Vehicle* is produced for the prototypes, with both scales using the same principles. The actual living space is positioned on a mechanical pedestal that is presumably meant to be hidden underground. From the bottom up, a vertically oriented stepper motor drives a turntable via a timing belt. This provides the azimuth rotation of the housing pod. The altitude rotation mechanism resides entirely on the turntable.

The pod is shaped so that two rings exist that protrude from the internal space, effectively creating two curved columns in the space that stiffen the entire pod structure. The rings define the altitude rotation of the pod, with the pod rotating around their centre. Each ring rests on two support wheels that allow it to rotate freely. A timing belt around each ring runs through the support mechanism below, which is also equipped with a tensioning mechanism. A horizontally oriented stepper motor, fitted with a planetary gear, drives a horizontal axis, which in turn drives the two timing belts around the two rings.

Even though the principle of the pan-tilt movement could feasibly be scaled to a functional building (at five times the size of the prototype), some adjustments would be expected in the drive mechanism. The turntable first, would have to withstand the eccentric load conditions that will occur in the housing pod, loads that will increase when the pod is occupied and subject to external wind and seismic loads. The altitude rotation would presumably not be driven through a belt, but for example by a curved rack and pinion.

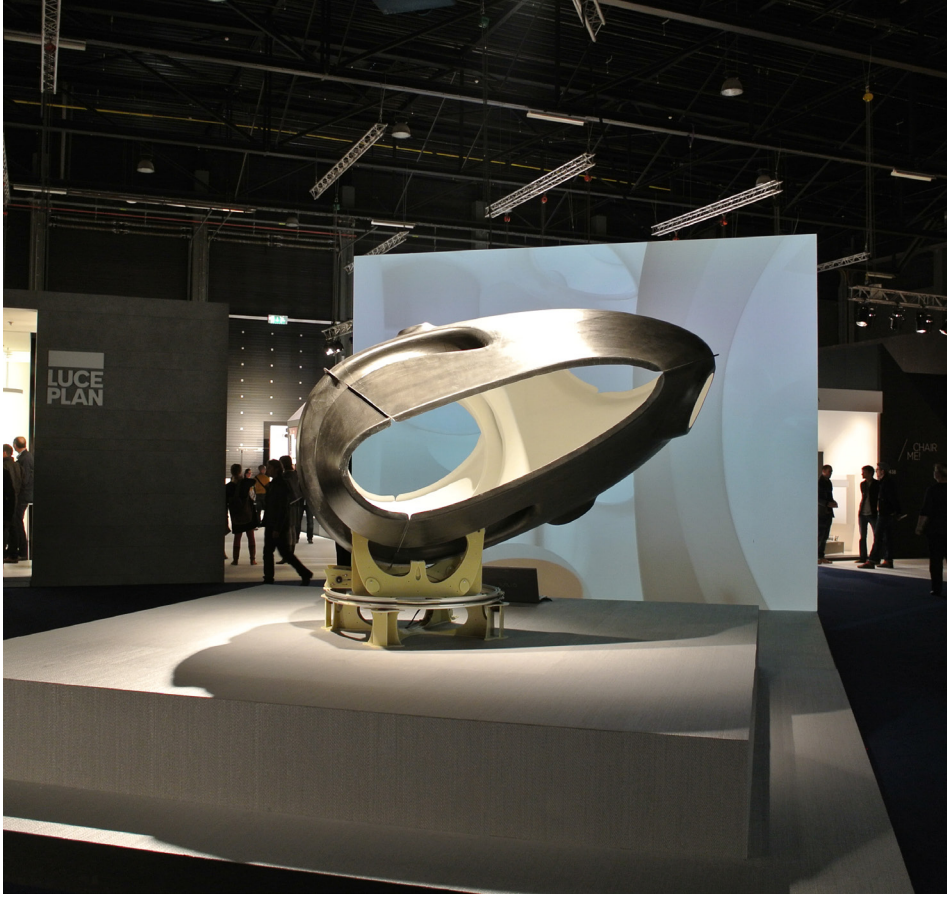

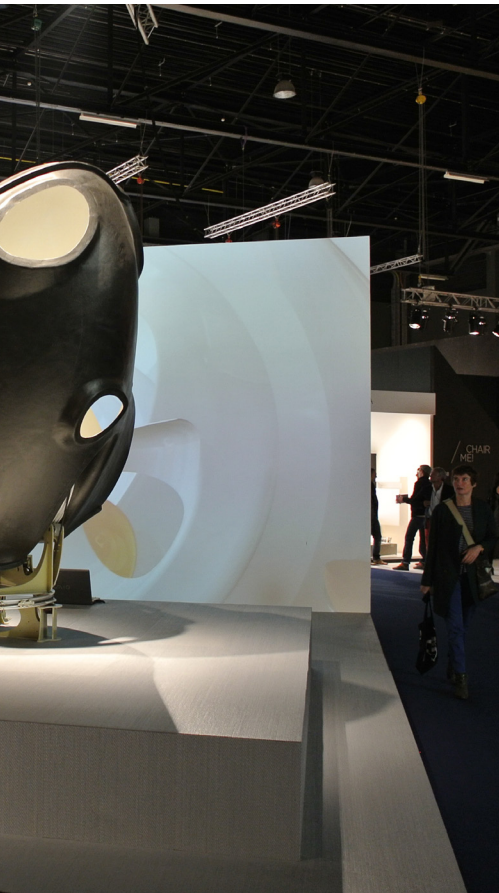
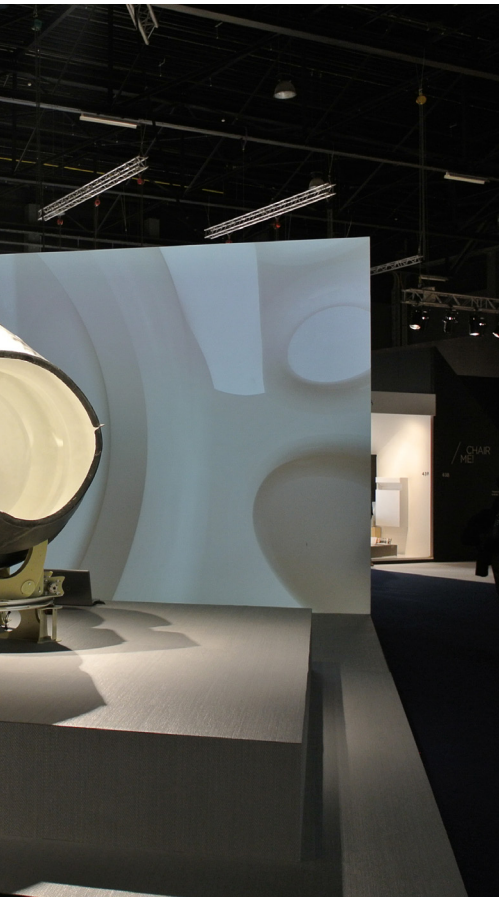

## Movement

Lynn has expressed the desire to build *Room Vehicle* at full scale, and without it, it remains difficult to imagine what it really entails to be inside it, or to live in it. At the *Hello, Robot* exhibition in the Vitra Design Museum in 2017, I observed the 1:25 prototype, but it lacks the detail to imagine some plausible scenarios of the building in use (figure 4.82). It was not moving. A problem with it seems—not as some have suggested that the toilet floods the bedroom—but how one negotiates the space with multiple inhabitants. A conundrum that has also been raised with regard to smart buildings that cater to the needs or desires of the occupant. In his playful description, Lynn suggests the space can be scaled, rather than merely trodden, but this excludes many, if not most, people as potential users. Dedicating the space to a single user seems to run counter to the claims of sustainability and small footprint that are made about the building.

However, this is probably not how we should understand the project. As a prototype, the project investigates a narrow aspect of how robotics could change the way we use buildings. The range of possibilities that was lacking at the time of writing *Animate Form* may now be available through advances in automotive and entertainment industries. Rather than a limited set of conditions, movement can be more fluid and continuous through contemporary building technology that Lynn refers to as robotic. This not only allows for a rich use potential, it also offers a broader choice in form language that would suit different architectural expressions. Lynn has explored this further through his teaching at UCLA and through other robotic projects in his studio (UCLA Architecture, 2012).

**4.87** RV (Room Vehicle) House Prototype. Three positions at Biennale Interieur in Kortrijk.



## 4.9 Envir()nment (2017)

*Envir()nment* is a research prototype that was produced in the context of this PhD project. The aim of the work was to explore movement as a primary design concern of architecture. Movement had been the starting point of the design and would not be limited to a single surface, as is often witnessed in building facades, but would encompass the whole space. It would also explore movement beyond functionality, although the outcome has now raised an interest for commercial purposes and ideas for applications.

*Envir()nment* is not an engineering prototype that aims to solve a technical problem, but to develop a line of thinking. In that sense, it can be regarded as a physical placeholder for thought, as with the technology of writing, or any other mnemonic device that can help to store thoughts externally to the human body. The development of the prototype, as well as its instrumental role in the research, is discussed in detail in chapter 3, Prototyping.

The title *Envir()nment* is a reference to the *environments* produced from more or less the mid-1950s until the mid-1970s by kinetic artists who were investigating aspects of movement in art. *Trigon* was a three-nation biennial founded in Graz in 1963, showcasing contemporary art from Austria, Italy and the former Yugoslavia. The exhibition in 1967 was entitled *ambiente / environment*, and was the first themed edition of the biennial. Work shown included *Spazio elastico*, an environment produced by Gianni Colombo, discussed in section 4.7.

Anne Ring Petersen explains that *environment* was the word used for art that we would now call *installation*. In tracing the origins of installation art, Petersen observes that authors such as Roald Nasgaard and Rosalind Krauss at the end of the 1970s discuss this type of work in terms of the traditional discourse of sculpture (Petersen, 2015). She explains that the word *installation* was reserved in the 1960s and 1970s for the preparatory process of hanging or placing artworks at exhibitions. Petersen includes environment in her broader category of installation art and locates the replacement of the term environment with installation over the period 1978–1993.

Jennifer González makes a distinction between environment and installation, however. Although “the words ‘environment’ and ‘installation’ have been indexed synonymously in reference guides for almost twenty years”, she writes, “[i]n environment art, it is implied, the audience literally enters into the work of art, becoming a functional part of the art itself or at least physically encompassed by it” (González, 1998, p. 503).

The title of the research prototype is thus a reference to the investigative, kinetic, and spatial properties of environment art. The association with *built environment* is a further reason for using it. The round brackets that together form the *o*, refer to the arches used in this prototype.

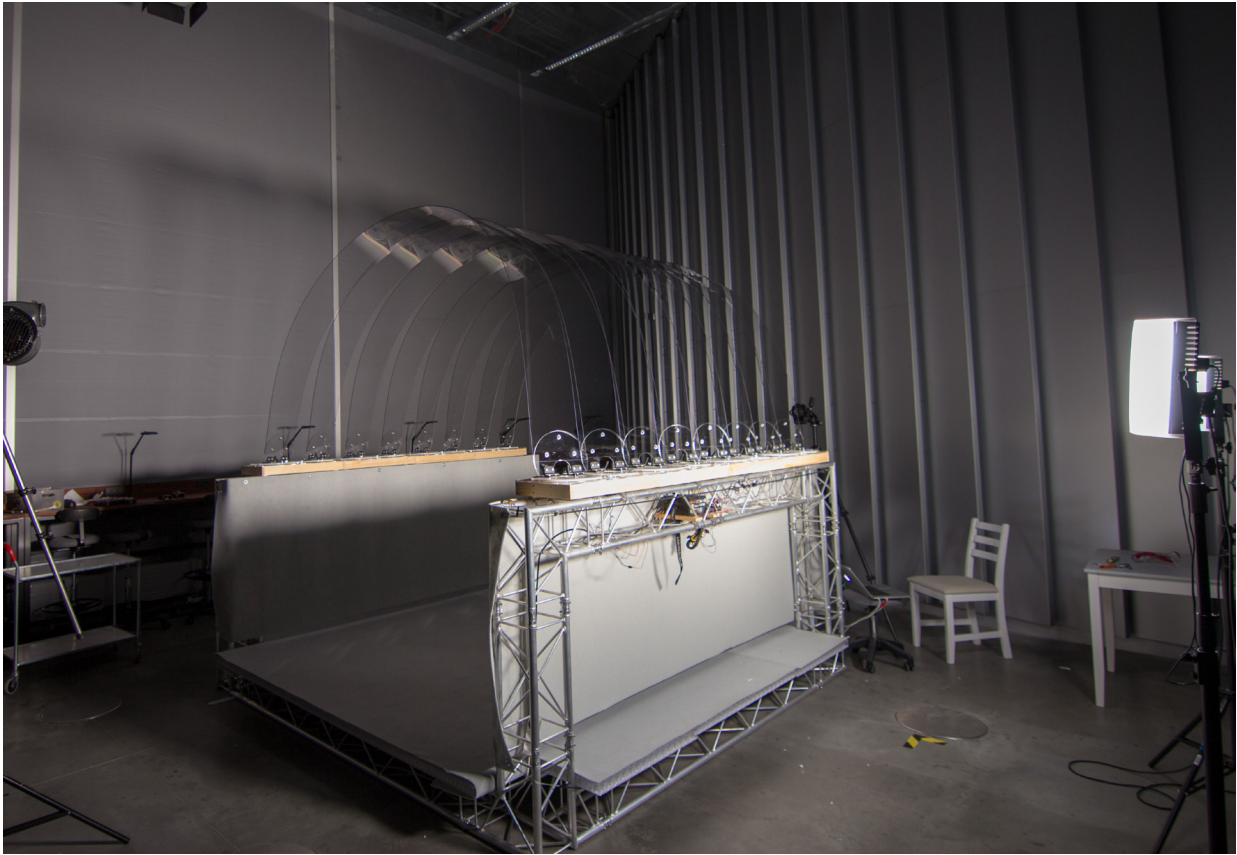

4.89 Envir( )nment. 30° base rotation.

## Appearance

The distinctive feature of the prototype is an array of eight transparent, glass-like arches that are formed from thin strips, bent over a square floor plan. The arches are raised, creating a space underneath, high enough to stand in. They may seem delicate and frail, or hard and reflective, depending on the light conditions. The arches move. They are flexible enough to be excited by airflow. Airflow is generated indoors with a blower that can be directed, as it is mounted on a tripod. In wind, the strips quiver, creating wave patterns that are most prominent where the strips deflect the most, at the apices of the arches. The arches also move in a more controlled manner, driven by motors at their base, rotating the footings on which they rest. Simultaneous rotations of both footings, in opposite directions, make the arches twist and bend sideways. The controlled movement is slower but more purposeful than the wind-driven motion. The movement is also synchronised between arches, allowing them to move along predefined patterns.

The prototype consists of a square podium with two short walls on opposite sides supporting a series of flexible arches spanning the podium. As the word *prototype* suggests, it does not look finished. Around the outside, the aluminium trusses that support the podium and the arches are visible, as are wiring, some electronics and power supplies. Inside, the podium is covered with a grey carpet, and the same carpet is used to cover the walls. A plinth is mounted on top of the walls, along the full length. The plinth is made of timber, untreated, and topped with a layer of acrylic. The arches run from plinth to plinth.





4.90 Envir()nment. Arch footings on turntables.

## Moving Parts

The support structure is an aluminium frame, assembled from Prolyte E20V stage-technology square trusses of different lengths. Directly on the floor, four 2-m-long trusses form a square and are connected with four corner pieces. At each corner, a shorter 0.5 m long truss is mounted vertically. Along two sides, a 2-m truss connects the top ends of the vertical trusses, the top side at 1.3 m above the floor, providing a horizontal structure to support the plinth and leaving two other sides open. Three cellular polycarbonate floor panels, each 1 m wide, span the bottom trusses, providing a podium that is raised about 0.3 m from the floor, thus requiring a single step to enter. To avoid large deflections of the floor, a number of short segments of truss are positioned under the floor panels to act as additional supports. A *medium-grey* carpet, perceptually halfway between white and black, covers the floor panels.

Prolyte provides brackets for its trusses, that clamp around the main tubes and have a hole that allows a bolt to be tightened onto it. These clamps are used to hang the vertical carpet of the higher truss and to mount the elements that form the plinth.

The plinth consists of four units on either side. These units are timber frames, measuring  $300 \times 600$  mm. A frame of untreated pinewood,  $15 \times 55$  mm in section, is made of four long elements of 570 mm in length and two short sections of 300 mm on either end. Square brackets allow for mounting the frame to the clamps on the

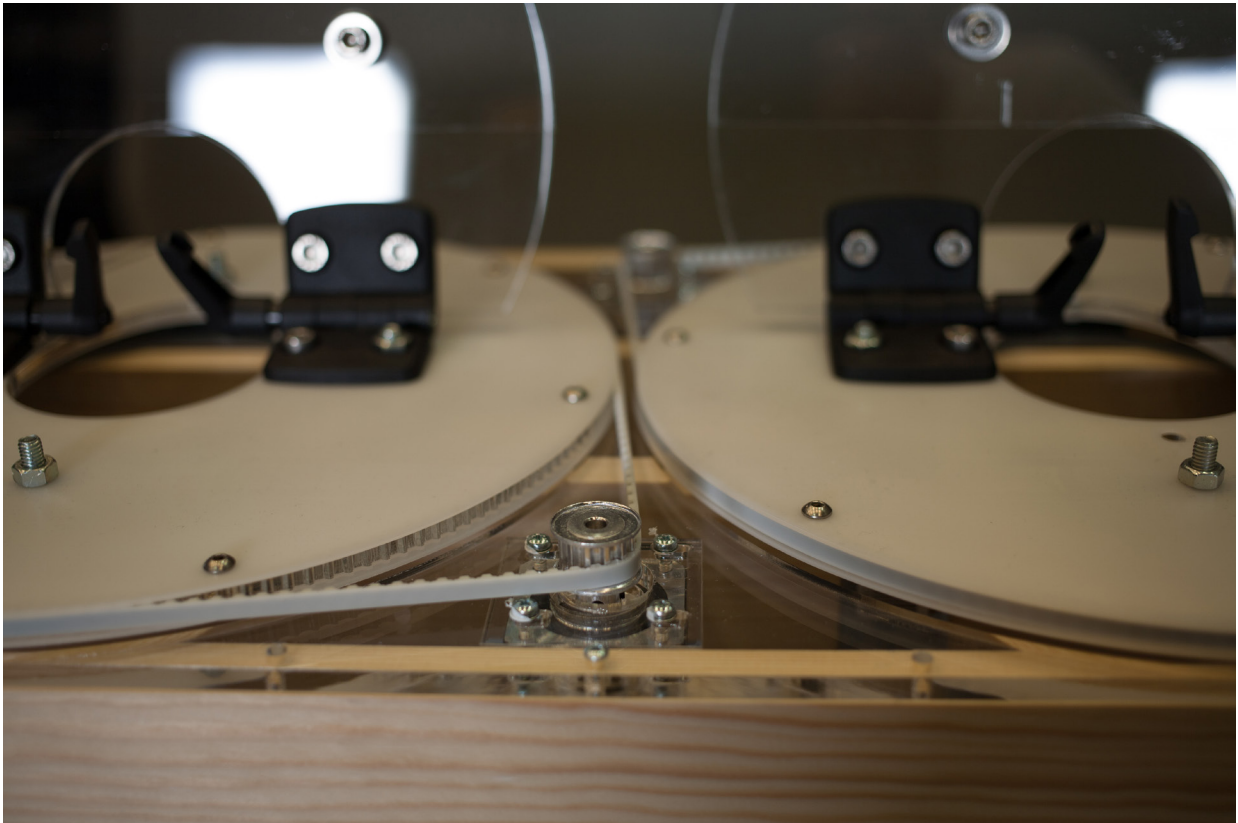

**4.91** Envir()nment. Detail of drive mechanism.

trusses. The frame is topped with a 6-mm-thick transparent acrylic plate, with circular openings for the turntables.

Each frame holds two turntables of 294 mm in diameter (figure 4.91). The turntables are assembled from various parts. The cog at the core is laser cut from the same piece that forms the top plate of the frame. The cog is cut for a T5 drive belt and has teeth along three quarters of its circumference. At the ends of the teeth rack, slots cut into the cog to fix the belt in place. The cog is sandwiched between two white POM (acetal) 1-mm-thick plates that act as flanges for the cog to guide the drive belt. The turntable is mounted on a circular Lazy Susan bearing, which, in turn, is fixed to the timber frame below. Two adjustable hinges on top of the bearing connect it to the arch. The hinges are made of black fibreglass reinforced thermoplastic, with a steel locking mechanism that can be manually tightened with a lever on one side. Twelve bolts are used to connect all components of the turntable together. Six M4 button-head bolts, with hex sockets around the circumference of the cog, lock the flange plates in place. Four M6 bolts lock the cog to the rotary bearing, two of which also fix the hinges on top of the turntable. Two additional M6 bolts are also used to fix the hinges.

The adjustable hinges hold an acrylic transparent 6-mm-thick holding plate that serves to connect the arches to their supports. The holding plate is part of a circle, with a central circular hole and with a flat bottom. There are seven smaller holes for bolts, four aligned horizontally at the bottom to connect to the hinges, and three higher up, in a triangular configuration for connection to the arch.

The arches are formed from strips of Makrolon® 2099 polycarbonate, with a layer of UV protection on either side. The material is transparent with 87% light transmission (Covestro, 2017). The strips are 4 mm thick, 250 mm wide and 4050 mm long. Mounted at 2580 mm spacing, and with a starting angle of approximately 15 degrees, the height of the arch is around 1.4 m, placing the top of the arch at around 2.5 m above the podium floor. The strips are connected to the holding plates with three M6 hex-socket bolts and a washer on either side.

There are two turntables on each frame. Each turntable is driven by a bipolar NEMA 17 stepper motor with a rated holding torque of 0.65 Nm (Stepperonline, 2017). A 10-tooth aluminium pulley with two grub screws is fixed to the axle and drives a 4 mm wide T5 timing belt. In order to package the components inside the frame, the two motors are placed on opposite sides, midway along the sides of the frame. The motor is fixed with four M2 bolts placed in slotted holes in the top plate to allow for adjustment of the drive-belt tension.

The motor drivers and controllers use a setup that is, in part, similar to that used in certain RepRap 3D printers. The drivers are A4988 breakout boards on a RAMPS 1.4 motor shield, on top of an Arduino Mega single-board microcontroller. A RAMPS 1.4 shield can host five motor drivers, therefore, in order to drive the eight stepper motors on each side individually, a twin set of four motor drivers, RAMPS shield, and Arduino Mega is used. The two Arduino Mega boards are linked to an Arduino Uno using an I<sup>2</sup>C bus, with the Arduino Uno as the master board. A power supply provides 12 V power for the motor shields. This setup is identical on either side of the arches. The two Arduino Uno master boards are connected through USB to a laptop that runs a script for generating synchronised motion. The script is written in Processing, using the controlP5 library to enable a user interface.

## Movement

The prototype can be found in a number of modes of activity. *Envir()nment* is either still, moving by air currents, moving by motors, or by a combination of air and motors. Movement through air currents is irregular, with the emerging patterns appearing natural, like the reflections from waves in water. The shape of movements is fragmented, and its dynamic is irregular and multidirectional. The forces that drive the motion are external to the work, in Mark Goulthorpe's words, the space "operates as a device of reciprocity, no longer autoplactic but *alloplastic* (the architecture itself constantly adjusting in response to variable environmental parameters)" (2009, p. 82). Reciprocity, it should be emphasised, implies that both the external force and the object at work are affected. In practice, this means that air currents drive motion into the arches, but also that the currents themselves are transformed, causing local climates of directional change and turbulence.



4.92 Envir()nment. Transparency and reflections.



4.93 Envir()nment. Movement sequence, external reflections.

The movement by motors is regular, following patterns of code. The arches perform synchronised swings, all in tandem, in canon or biparting, causing a travelling ridge that moves uniformly in a linear fashion. The motorised movement comes from within the work, is intrinsic to it. The organisation and physical properties of the arches prefer certain movements and forbid others. For example, the two turntables of each arch operate in opposite directions not only to induce the sideways movement of the top, but also because this requires the least resistance. Moving just one turntable, or moving both in the same direction requires higher torques. Movements that are not allowed are those that may damage the strips through collision. This might occur if the movements of adjacent arches are not coordinated.

When both forces—air currents and motors—are acting at the same time, additional phenomena occur. The air currents have a different effect on the arches when they twist, exciting them more when the air hits an inclined surface. Apart from an extreme position from the motorised movement's point of view, the wind-induced motion would also be more extreme, creating a wave pattern in the observed amplitudes. Air can also be felt changing direction when the overhead current is directed downwards.

One of the aspects that is most apparent when the arches are moving is the effect on light and reflections. Standing inside on the podium or outside the structure, the movements of the arches cause reflections to shift, or light to shatter and produce intricate patterns on the surrounding surfaces. The shifting and distorting reflections are caused mainly by the motorised movements. Depending on the position of the main light sources (electrical or daylight), reflections can be more prominent inside or outside the work (figures 4.93 and 4.94). With clear reflections from the material, the movements through wind give the structure a fragile quality, almost like a soap bubble. Light shone through the arches produces projected patterns that closely resemble light reflecting off a water surface. This directed light also accentuates the edges of the strips, creating a visual tangle of line work and dissolving the bearing material.

What results is a space that is bound by movement. The material that encloses it is transparent and visually disappears until it presents a reflection of something else. It is the felt variation of airflow that defines a context where air is modulated as such. The visual transformation of the surroundings and the active modulation of air establish the spatiality of the work; *Envir()nment* defines itself in the dynamic transformations of the environment.



4.94 Envir()nment. Movement sequence, internal reflections.

4.95 (page 228-229) Envir()nment. Transparency in motion.





## 4.10 Enactive Works

This section concludes chapter 4, a chapter that comprises analytical descriptions of nine works of architecture and art. The chapter begins with a substantiation of the selection process of the nine works that are the main subjects of the sections in this chapter. The works have been chosen based on the criteria for movement set out in section 2.3.5. Within the constraints of those criteria, a collection of works has been created that is diverse in terms of the manifestations of movement. The individual descriptions in each section of this chapter provide rich accounts of the works, place them in contexts, and focus on technical details that underlie the movement mechanisms. More subjective interpretations of the works in motion are also written, providing the beginning of an understanding of the works in the context of enaction. The sections that follow develop that understanding of each work by bringing them together in different ways. The enactive notions of acting out, coupling, and exteriorisation are the markers for that process of structuring.

### Acting Out

Acting out, as described in chapter 2, refers to the idea that cognition is constituted by action on the part of the cognitive agent. In order to bring forth a world, the agent creates a disturbance that allows it to gauge patterns of change. The actions of an agent are deliberate movements made possible by its physical structure, its ability to move. All the works described in this chapter demonstrate a particular way of movement that is uniquely related to the structure of that work. Even though the project descriptions account for similarities in other architectural or art projects, their likeness never renders them equal. Movement in the nine works is an integral part of their architecture, so much so that these buildings can be said to be characterised by their particular movements. These movements, whether driven by motors or by external forces, are deliberate, intentional movements. The buildings were designed this way. And these movements cause disturbances of the environment, external or internal. This suggests that the enactive notion of acting out can be attributed to all the works in this chapter. In being characterised by their movements, the movements make these buildings what they are—these works enact themselves.

*Dottikon* enacts itself through the movements of 329 individual black balls, together forming a swarm of movement. *Hyposurface* is enacted by the coordinated movements of pistons attached flexibly to a pliable tessellated surface. And the facade of the *IMA* is made to move by the simultaneous movements of 13,680 diaphragms, enacting an intricate interpretation of the traditional mashrabiya. The different configurations of large numbers of actuators and their coordination give rise to very specific movements. The individual movements in these works are interpreted collectively, and are attributed to the building as such.



The *Wacoal-Riccar Pavilion* and *Blur Building* are enacted by movements that are not just activated by the wind, but the motions are shaped by the wind. In the case of Wacoal and Riccar's bobbing roof at the Japanese Expo, variations in wind direction would rotate the roof, which was made visible by a large red fin. A significant effort in the use of a precision slewing bearing was made to achieve just this rotating behaviour alone. *Blur Building* is shaped entirely as the result of environmental factors, with the wind shaping the cloud into a turbulent mass of moisture, a rising mushroom, or a stretched ribbon across Lake Neuchâtel.

In terms of the complexity of movement itself, the up-and-down platform movements of *Maison à Bordeaux* and the tumbling of *Room Vehicle* are relatively low-key technological achievements. Although the implementation of the platform in Bordeaux had its share of technical problems, the movement itself is common in many buildings and is activated here by a single actuator. Similarly, the alt-azimuth rotation of *Room Vehicle* is a standard setup for many structures, some significantly larger than this prototype. But the interest lies in the implications of these movements, and their transformative power. These projects enact themselves in reconfiguring over and over the three-floor plans of a villa, or by eliminating the plan entirely in turning it upside down.

*Spazio elastico* and *Envir(On)ment* act themselves out by transforming the sense of space. In *Spazio elastico*, this transformation is made from within the space, whereas in *Envir(On)ment* it is achieved by working from the contours. The first work focusses inwards as a dark space isolated from the world. The second draws in the world by being transparent and by modulating the external environment. A contrast also exists between the actual movements of these works. Although in both cases movement is activated from the edges and relies on the elastic deformation of material, the stretching and shifting of straight lines in *Spazio elastico* is markedly different from the bending and twisting of arches in *Envir(On)ment*.

This acting out of the works determines largely how the works relate to their environment. This will be analysed in the next section in terms of the enactive concept of coupling.

## Coupling

The enactive concept of coupling is described in chapter 2 as the specific way in which the structure of an agent is sensitive to its environment and how that agent chose its environment. Varela et al. (1992) discuss this as a mutual specification: an environment provides conditions for an agent to be sensitive to, while an agent brings forth an environment by being sensitive to certain conditions. Biologically, they write, this coupling develops over generations, but the coupling takes place directly between a specific agent and its environment.

In this analysis, I will identify three modes of coupling that extend the agent–environment coupling that is described by Maturana

and Varela as a structural coupling (1992). Although they will be described separately, these modes may all occur simultaneously, even influencing each other. Diagrammatically, the modes are presented in figure 4.96. The first diagram shows structural coupling as presented by Maturana and Varela, the adjacent diagrams present the three modes discussed in this section. A point to note is that Maturana and Varela use different diagrams for autopoietic single and multicellular systems (a single circle with arrowhead and two intersecting circles with arrowheads respectively). For the sake of clarity in my own diagrams, I will use the symbol for a single cellular system and I use the arrowhead to indicate an agent with cognitive abilities.

(1) The first of the three modes is the coupling between agent and building. In this case, the building is the agent's or the occupant's immediate environment. This environment is the result of design. The capacity of the occupant to navigate a building may not necessarily be the result of evolution, but the building is built around the capacities of the occupant: there are steady floors to walk on, windows to look out of, and there is a roof high enough to stand under. Works discussed in this chapter that are focused inwards, such as *Dottikon* and *Spazio elastico*, are exemplary illustrations for the coupling between building and occupant because they largely leave out a relation with the external environment. These two works are produced to induce a specific perception of the space. The movements are tailored to produce effects in human occupants. Just like stairs in more common buildings are shaped to facilitate stepping, so are the movements in *Dottikon* and *Spazio elastico* shaped to be perceived. On the other hand, the perception of the movements brings forth a highly specific environment. In the case of *Dottikon*, the individual movements of 329 machines give rise to a unified throbbing motion, and a connection between the individual movements is made by the occupant. In *Spazio elastico*, the individual movements of three motors are connected by an elastic grid. Here, the stretching and warping connections give rise to movement of the space.

4.96 Modes of coupling.

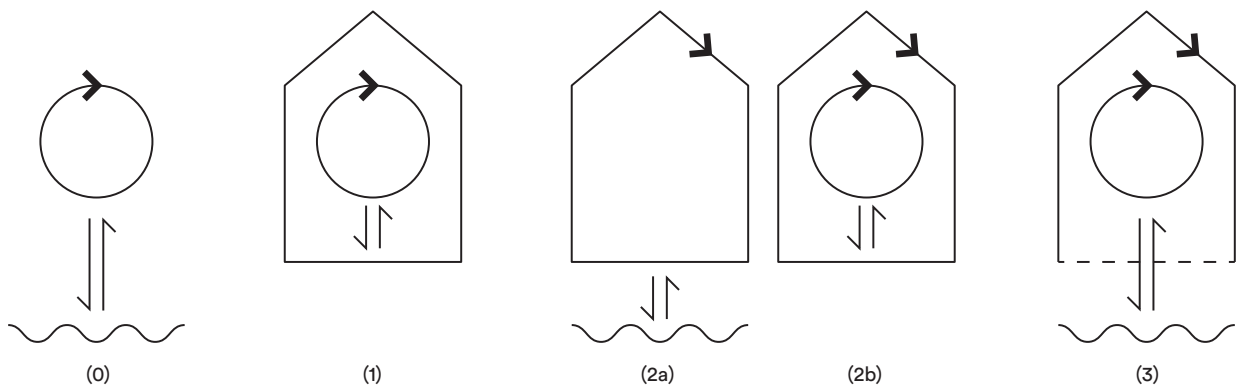

(2a) The second of the three modes is the coupling between building and environment. For the building, this environment may be external or internal. The internal environment includes the occupant. Again, we should consider the building, in this case the agent, as a product of design that is made sensitive to its environment. The coupling between building and environment is therefore not the product of biological evolution. However, more generally, the development of building technology can be said to have evolved over many centuries. A coupling to the external environment is illustrated by the *Wacoal-Riccar Pavilion*, *Institut du Monde Arabe*, and *Blur Building*. These works display movement in a coupling with the external environment—their designs have made them sensitive to particular aspects of their physical environment. In the *Wacoal-Riccar Pavilion*, this coupling determines how the roof of the pavilion moves in response to wind and seismic activity. The counterweight in the basement, the bearings on top of the cone, and the dimensions of the fin, all contribute to this sensitivity. The moving facade of *IMA* has a sensitivity for light and moves in a particular way to reduce or increase the flux of light that filters inwards. Even though the movements in *IMA* are motorised and controlled by a light sensor (not as directly as *Wacoal-Riccar*), the intricate mechanism of the facade—the actuators, the linkages, the different-sized diaphragms—establishes a system that, as a whole, responds to variations in daylight conditions. In this respect, *Blur Building* is perhaps the most complex example, because its capacity for making mist depends on a range of conditions. These conditions—wind speed, air temperature, humidity, dew point—are measured by a weather station and determine which spray nozzles are operated at what pressure. Even given this control, the cloud formation will differ in varying conditions, visually expressing the dynamics of the reciprocal coupling.

However, even if the building does not directly or indirectly respond to environmental stimuli, it may still be coupled to its environment. Similarly, as static architecture is sometimes said to respond to its site, architecture that is kinetic may do the same through movement. West 8's robotic light poles (figure 4.97) on *Schouwburgplein* (1996) in Rotterdam, Netherlands, move as cranes in the nearby harbour. *Blur Building* (section 4.5) sprayed water from the lake on which it was built.

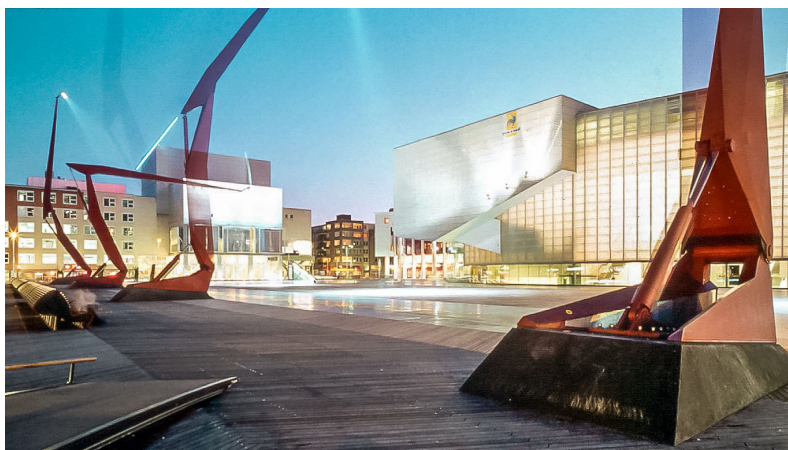

4.97 West 8, Schouwburgplein.

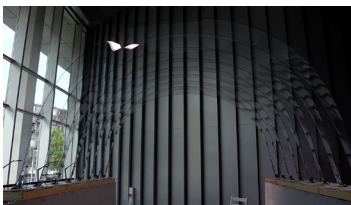
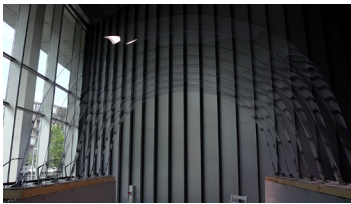
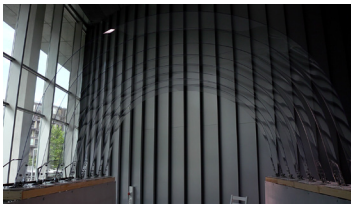
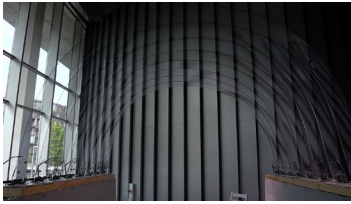
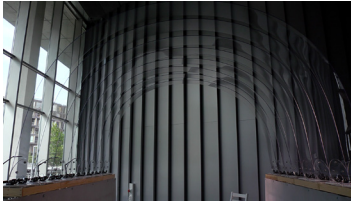
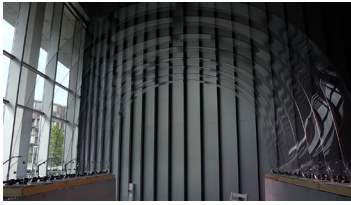
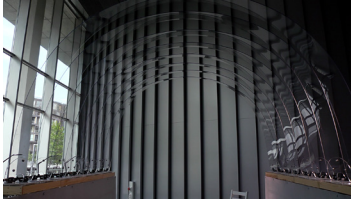
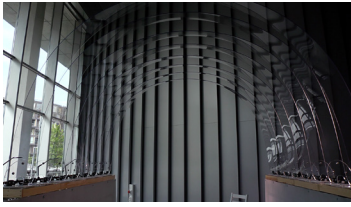

(2b) A coupling to the internal environment, to the occupant is expressed in *Hyposurface*, *Maison à Bordeaux*, and *Room Vehicle*. In the first mode, we also analysed a coupling between occupant and building, but what distinguishes this second mode is the emphasis on agency of the building, suggesting that there is a sensitivity to occupation. The coupling between two agents is of a next order (Maturana & Varela, 1992). Even though it makes no difference to the internal structure of each agent whether a coupling exists between environment or another agent, a coupling between agents may give rise to social phenomena. Even though *Hyposurface* is not inhabitable, we could refer to those affected by the wall as occupants, and argue that a sensitivity for occupation exists that is manifested when the wall operates in a responsive mode. This responsive mode is informed by sound and motion tracking: movements and sounds of people near the wall trigger certain predefined motion patterns. In *Maison à Bordeaux*, the sensitivity for occupation is ingrained in the operable platform. In this case, the movements of the platform are not automatic (although the security barriers do move automatically in response to the platform movements), but the platform, and consequently the whole building, is sensitive in a specific way to how it is used. Moving the platform to another level, changes the conditions on the platform, but also reconfigures the otherwise static floor plans. A similar sensitivity for occupation is present in *Room Vehicle*, which is operated by occupants to move into a certain position; each position opening up different use cases.

(3) The third of the three modes concerns a coupling between occupant and external environment. This third mode of coupling is affected by the building—the building becomes part of the coupling. Following Di Paolo's description of insects' use of air bubbles (Di Paolo, 2008), discussed in chapter 2, the building environment is said to *mediate* the coupling between occupant and external environment. *EnvirOnment*, the research prototype that was built for this research, illustrates this third mode of coupling. When the occupant stands inside the prototype, or directly next to it, a visual relation exists with conditions of the external environment such as wind, light, cloudiness, and traffic, enabling a coupling to that environment. However, the conditions of the moving prototype affect the perception of the external environment. For example, by twisting the strips, the view outside is distorted and the reflections are moved sideways or apart (see figure 4.98).

Moreover, *EnvirOnment* unifies all the three modes of coupling. It is designed to affect perception in a certain way, which makes a coupling of the first mode. The second mode of coupling is the prototype's sensitivity to occupation and to environment. As *EnvirOnment* is programmable by the occupant, it has that sensitivity, but also, by being excited by airflow, it is sensitive to environmental conditions. The third mode is the mediation that takes place of the coupling between occupant and environment.

Related to the enactive concept of acting out, the particular way that a building moves couples the occupant to the environment in a specific way. The transparent strips of the prototype are made to be sensitive to the airflow and express this in movement. The transparent strips also distort the view of the world looking through

4.98 *Envir()nment*. Sequence shows swing away from camera.

the strips, or looking at reflections either inside or outside the prototype. In this way, the strips allow the occupant to become attuned to the sensitivities of the prototype—in the way it responds to airflow and the way it mediates light. How an occupant is visually or otherwise coupled to the environment is now mediated by the building. The occupant can be said to be coupled to the environment in a building way: getting a sense of windiness, for example, by seeing the giant roof of the *Wacoal-Riccar Pavilion* (section 4.3) wobble, or getting a sense of brightness from the state of the diaphragms in the *Institut du Monde Arabe* (section 4.6).

## Exteriorisation

The enactive mode of exteriorisation accounts for cognitive processes that take place outside the physical bounds of an agent's body. Up to this point in the thesis, exteriorisation has been related to buildings in two ways. The first way is developed in chapter 3, in the context of developing the research prototyping. In this sense, exteriorisation is about employing the work to advance thought. Four mechanisms are described in section 3.3 that position the prototype as a milieu for associated exteriorisation.



4.99 Gerrit Rietveld, Rietveld Schröder House. Interior.

The second way in which exteriorisation has been related to buildings is with regard to occupation. An associated relation between agent and technology—occupant and building—may exist, meaning that the technology allows for both storing and making memories available. The illustration in section 3.4 of how, through movement, a building can store memories of occupation is Shigeru Ban's *Naked House*. Another example is Gerrit Rietveld's *Schröder House* (1924) in Utrecht, Netherlands (figure 4.99), which was designed in such a way that internal wall panels can be moved to suit different forms of usage. The works of this chapter that address such coding and decoding most explicitly are the *Maison à Bordeaux* and *Room Vehicle*, because these can be reconfigured directly by the occupant.

A third way of exteriorisation can be found in the mediated coupling that may exist between the occupant and environment, and that is described above. When a building mediates the coupling between occupant and environment, it may become appropriated by the occupant's perceptual system. The vibrations of the strips in *Envir()nment* become an exteriorised sense of airflow. The cloud formations of *Blur Building* become an exteriorised sense of the specific conditions on the lake. This is not the same as reading values from a display, which are merely abstract representations of the conditions. This is rather about a co-sensitivity that allows occupants to sense the environment through the specificities of the building. *Hyposurface*, *Wacoal-Riccar Pavilion* and *IMA* also allow for such exteriorisation because they facilitate similar mediated couplings.

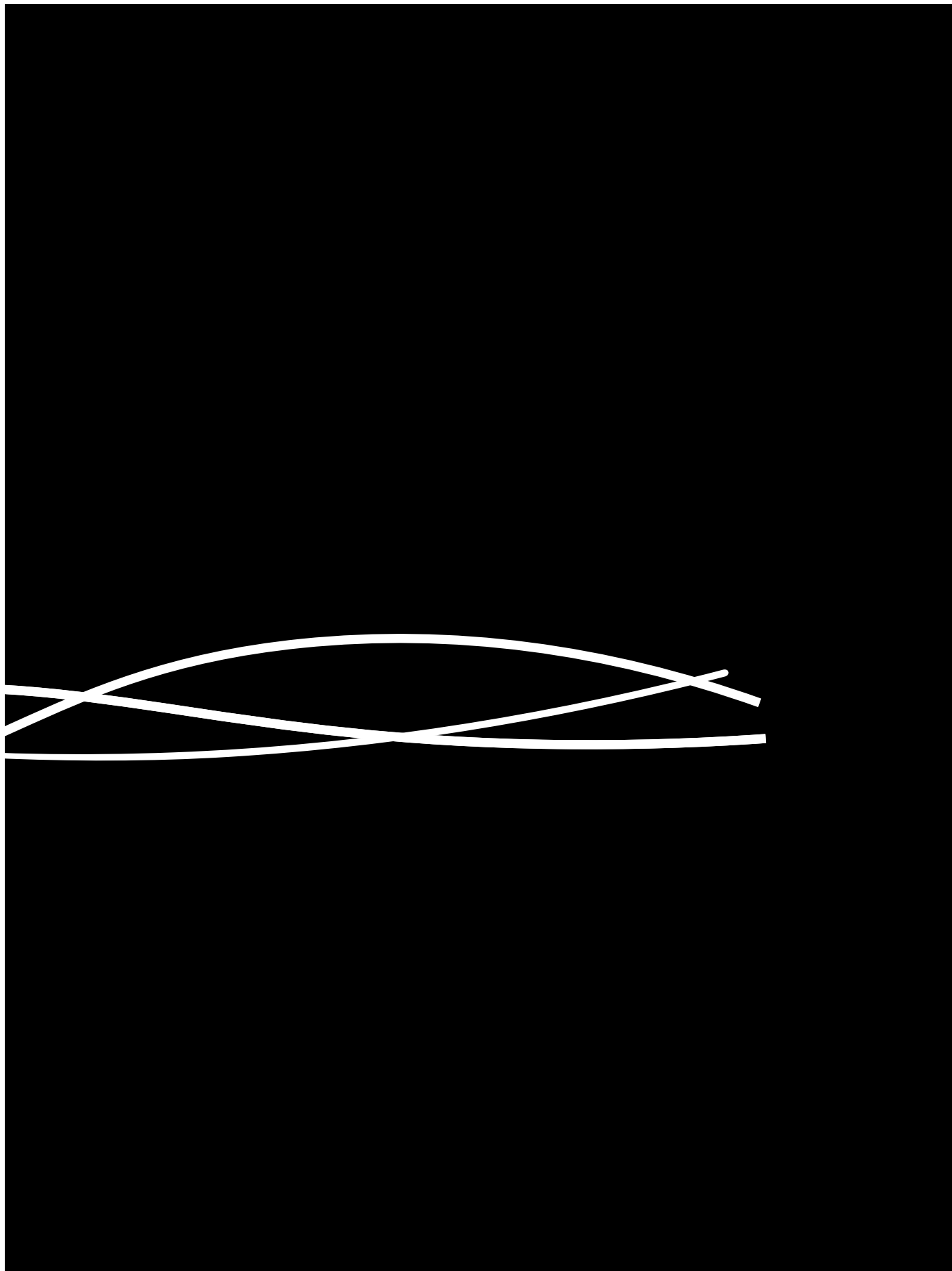

# 5.

# Moving On

*Railroad Turnbridge* (1976) is a short film by Richard Serra.

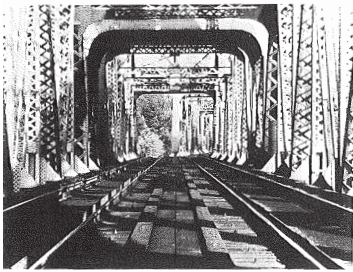
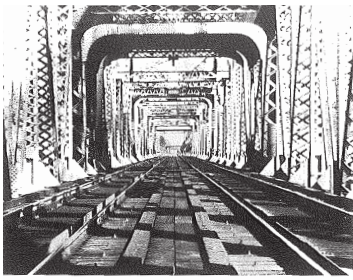

5.1 Richard Serra, *Railroad Turnbridge*. Stills from the opening shot.

*Burlington Northern Railroad Bridge 5.1* is a double-track steel truss rail bridge across the Willamette River in Portland (OR), US. It consists of five sections, of which the middle one, the longest, is movable. The bridge was a swing bridge until 1989, meaning that the middle section would turn horizontally around its centre to allow ships to pass. The middle section has since been replaced with a lifting section to widen the channel and ease navigation for passing ships.

Serra's film is shot from the bridge, documenting its operations. The film is shot on 16 mm, with a total duration of nineteen minutes, and consists of thirteen shots, all but two of them from a static camera perspective.

The opening shot, which is probably the most famous, lasts almost three minutes, and is taken from a position on the movable part of the bridge, towards the southern end (figure 5.1). Throughout the shot, the camera does not move relative to the bridge, and looks out in a north-easterly direction, following the tracks, when the bridge is preparing to open for ships. The bridge then turns open, panning across the landscape, but framed in the bridge structure, it is the landscape that seems to slide along. The patterns of shadows travelling in their own directions over the deck and the steel structure distinguish this from a similar shot later in the film. The shot ends when the bridge has turned 90° and the frame looks out in a north-westerly direction, towards St. John's Road Bridge in the distance.

Speaking about the work to film critic Annette Michelson, Serra remarks:

**Not only does it use the device of the tunneling of the bridge to frame the landscape, but then it returns on itself and frames itself. In that, there is an illusion created that questions what is moving and what is holding still. Is the camera moving and the bridge holding still? or vice versa? That is contained within the framing structure of the material of the bridge itself, right down to its internal functioning element—the gear. (Michelson, Serra, & Weyergraf, 1979, p. 76)**

The gear that Serra mentions is part of the seventh scene, in which two cogs are seen rotating against each other. Also here, ambiguity exists about what is moving what. With 13 scenes in total, the gear is the centre of the film, placing the driving mechanism at the heart of the work.

Revisiting Serra's film, John Bils identifies a *field of agency*, that has built works that "act in the world 'by themselves'" (Bils, 2010, p. 2). Bils brings to light four modes in which agency can be attributed to architecture, adding that these modes should be considered together, allowing us to speak "in a new way of an active architecture" (p. 7). Bils, to be clear, considers the film in his analysis. This way, he develops a position on agency in architecture that includes world, object, portrayal, and subject. To understand



his argument, it seems sufficient to regard the opening shot of Serra's film, as described above. This was the first shot that Serra captured in a project that took a year to shoot. The four modes Biln examines are (1) *moving world*, (2) *active object*, (3) *effective portrayal*, and (4) *mutable subject*.

(1) Biln writes about the *moving world* as the dynamic context of the bridge (the traffic on the road bridge, growth of vegetation on the banks, moving animals) and states that “[a]long with the effects of seasonal cycles, weather patterns and other moments of natural and artificial change, any or all of these can be expected to count as contributions to effective agency in and around architecture” (Biln, 2010, p. 6).

Following Biln, we can attribute agency to the waves of Lake Neuchâtel, the clouds that drift over Paris, and the cyclists riding outside IntermediaLab forming the environments respectively of *Blur Building*, *Institut du Monde Arabe*, and *Envir(onnement)*.

(2) The railway bridge is presented by Biln as an *active object* with intrinsic agency, illustrated, amongst others, by the bridge's structural configuration, weathering of the steelwork, changes in its expansion joints, and the speed and direction of movement.

This mode of agency is perhaps the most elementary to understand as an agency of the building proper, but as Biln explains, it cannot be understood fully without taking into account the other modes of agency.

The bridge's movement perhaps makes it a special, literal case of an active object because it brings a particular way of being active that is tied to its structural make-up and its mechanism. Here, activity is expressed in movement, as it is in Zimoun's *Dottikon*, which is active by means of 329 actuators, all acting at the same time. Or as in *Blur Building*'s 35,000 fog nozzles, that activate the building in another, specific way.

(3) *Effective portrayal* is an agency that Biln ascribes to the bridge being portrayed in the film. He notes that “[s]ince the transmission of architecture through images, films and other reproductions is virtually the only experience the majority of viewers will, or even could, have of many buildings, the question of a portrayal's claim to agency, in particular, cannot be ignored” (p. 3).

Portrayal provides a particular rendering of the work that might be understood as a layering of the intentions of the film maker, of the medium and the tools of its production, and of the work that is portrayed.

This agency of portrayal should be acknowledged in the context of this research, which relies partly on accounts, photographic, and video material of the nine kinetic reference works and many other references. Of the nine works, five have been directly experienced, three of those as actively moving. The movements of all but one of the works have been seen on video, like the bridge in Serra's film. The particular way that these films portrayed the works are the

result of decisions made by the film makers, showing some aspects, in a particular framing, and leaving out others.

(4) The *mutable subject* is described by Biln as the individual and collective audience of the film. Biln explains that in Serra's film, site and audience are paired and need to be understood together with the object-portrayal pairing. A *multiplying* of the building occurs where the viewer watching the film imagines being in the portrayed building, relates to the work through memory of other experiences, and so forth.

**The object work and various works of representation are always inter-implicated, just as our senses of self are always at play in our engagements with the world. Some form of intertwining is always present in the lived experience of architectural works and all works 'act' by way of this ensemble. (p. 3)**

Like the effective portrayal, and its relevance for this study, the mutable subject can be applied to myself, the researcher. My particular experience as an engineer in kinetic architecture brings with it a baggage of professional knowledge and expertise that renders visual material of moving architecture in specific ways. For example, having worked with spatial dynamic content in relation to two-dimensional representations (drawings, photographs) I can quickly visualise moving content in three dimensions. And in studying visual material of kinetic buildings, I am immediately drawn to the mechanisms and their implementations. References to parallels in other works are never far away. This is how kinetic architecture acts on me.

The mutable subject as occupant is said by Biln to give agency to the work through the lived experience of architecture. Agency therefore exists on the part of the occupant, and also, through the occupant, on the part of the architectural work.

A field of agency thus emerges in the negotiation of the four agencies. When we see Serra's film, and look through the bridge to see the landscape gliding past the opening of the bridge frame, all aspects of the field are at play. The environment, the architectural work, the representation, and the viewer. It would appear similarly if we looked at video shot from within Greg Lynn's *Room Vehicle*. The nearest available equivalent is a video rendering from the inside of the pod when it is moving (figure 5.2). However, the point of view is from a fixed global camera and no external environment is visible. Nevertheless, what is visible is the play of light resulting from the movements of the pod. Patches of light are shown travelling across the interior surfaces, while we also see the gimbaled furniture rotating in order to stay level. The travelling light patches are reminiscent of the shadows moving across the railway bridge in the opening scene of Serra's film.

When we watch film of the *Institut du Monde Arabe* we enter a similar field of agency. Looking through a diaphragm, we see Paris rooftops. The focus is outside. As the diaphragm closes, the focus moves closer until it is on the moving mechanism (figure 5.3). In this short scene, there is an external environment of buildings,

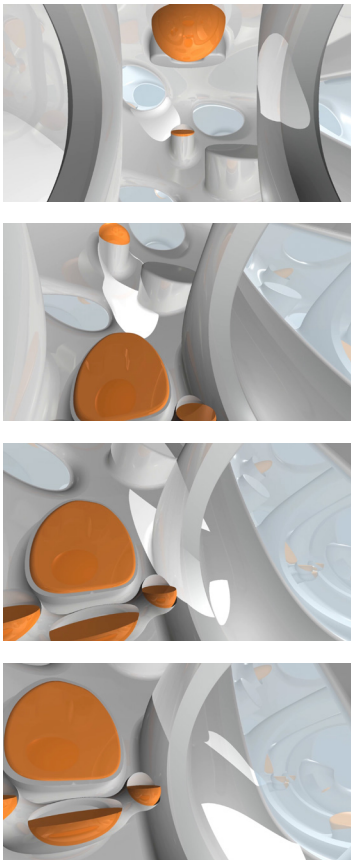

5.2 Greg Lynn, Room Vehicle. Stills from animation.

weather-worn and shaped by years of urban densification, alterations, and maintenance. The building is active, in this case literally acting through its intricate mechanism. The representation is also clearly present, making itself known through a significant racking focus, drawing the attention incrementally inwards. And lastly, there is the viewer, who takes in the scene and makes interpretations.

We could also consider the field of agency without the necessary inclusion of representation, but as soon as the subjective experience of visiting *Dottikon* or *Spazio elastico* is written down, the reader will be confronted, not with the actual being there in the work, but with an account representing that experience in a certain way.



5.3 Pascal Bony, *Les Diaphragmes de L'I.M.A.* Stills from shot starting at 11:59.

## Representation as a Middle Way?

The enactive account of cognition often takes aim at representations, but they differ from those described by John Biln. The type of representations that are contested are so called pictures in the mind. Representations in that sense, as argued for example by Alva Noë (e.g., Noë, 2004), are not required for cognition and make no explanatory sense. This is where, in section 2.2.3, Merleau-Ponty's idea of reversibility has been presented. Human perception is much closer to the world than an intermediate layer of representation would lead us to understand. Referenced also in section 2.2.3, Varela et al. speak of a mutual specification where we perceive a world in a manner that has evolved as a result from pressures of that same world. Rather than committing to a given external world, or to a constructed inner world, they speak of a middle way where both are inseparable.

In the enactive understanding of perception, we perceive photographs and film like the other things we perceive. Looking at a picture of a building, we can make out some aspects of that building, but only a limited number. Because we have first learnt how to perceive a physical three-dimensional object, we may experience more than we can actually see, but the representation is not experientially equivalent to the thing it represents. What we perceive is a picture of a building, we understand it is not the building itself. Noë suggests regarding pictorial representations as models that only show us a selection of whatever is represented (Noë, 2015).

Representations thus provide an additional layer of meaning that can often not be separated from the works they represent and from their subjective understanding. For architecture, this is first because buildings are designed as representations. Building designers cannot see and experience the outcome of their work until long after their work has finished. And second, as Biln writes, many buildings will only be available to most in the form of photographs and film. Not only are many buildings not open to visitors, or within physical reach, they might simply no longer exist. The availability for direct experience, or not, has also influenced

this research. This was acknowledged at the start of chapter 4 in the overview provided of the nine works and the various forms of representation that were relied upon.

Consequently, Biln talks of the agency of representation. Representations of buildings act on the viewer in specific ways, like they act on the building they represent. This acting back and forth becomes inseparable and might well be understood as a mutual specification. Similarly, we can understand the other agencies at play as inseparable, in what we now call, following Biln, a field of agency. The inseparability exists because environment, building, occupant, and representation act on each other in mutually constitutive ways. The field of agency allows us to identify the individual active relations, but then regard them collectively as part of one complex enactive process.

We can now revisit the mediated coupling, which was presented in section 4.10, figure 4.96, and add an arrowhead to the environment, indicating agency (figure 5.4). It should be noted that the diagram itself is the fourth agency at play. Within the context of environment, building, and occupant, it becomes clear how we can interpret these entities and their respective modes of agency as mutually constitutive. The coupling that is described in section 4.10 explains how the middle way is not just trodden by relating occupant and environment, but the role herein of the building. All of the nine works, and others that have not been discussed, have a particular sensitivity to their environment, and act themselves out by means of their given physical capacity to move. In doing so, their mediation further affects the coupling between occupant and environment. The *Wacoal-Riccar Pavilion* is acting itself out in a manner driven by external wind forces, and in that way affecting the coupling between occupant and environment. The occupant in the *Maison à Bordeaux* moves the platform, thereby actively changing the building and affecting the occupant's coupling to the environment.

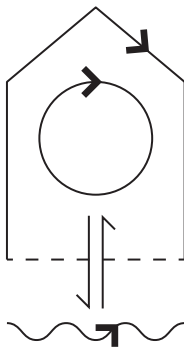

5.4 Mediated coupling in field of agency.

## How Can We Now Talk of Enactive Architecture?

The position of enactive architecture brings together the two vectors set out in chapter 2. These vectors represent cognitive enaction and architectural movement, and have given direction to the research from the start. Throughout the thesis, the two discourses they represent, one abstract, the other more concretely inclined, have been framed in a set of key concepts that became productive in processes of design and analysis. In chapters 3 and 4, we saw how the two framings worked together and discussed works of art and architecture as enactive. We saw how we can look at buildings as being defined by movement, and how such movement gives rise to a specific coupling between occupant, environment, and building.

The emphasis on movement serves a particular expression of cognitive ability. In order to define, or at least identify such movement in architecture, the concept of *structured movement*

has been developed. The neologism refers to *structure* as discussed by Francisco Varela and Humberto Maturana as the concrete manifestation of a system's fundamental organisation. Structure is what constitutes the system, hence structured movement of a building is inseparable—it makes a building what it is. Structurised movement is *intentional* through design, it is *actualised* through construction, and it operates *beyond utility*, layering significance on top of core functionality. As we will see next, in this way, architectural movement, can be qualified to ascribe aspects of cognition to the building.

Cognitive enaction has been framed in this research through the concepts of *acting out*, *coupling*, and *exteriorisation*. Acting out is the physical ability to move in ways that bring forth meaning in a particular environment. Such movements establish a certain sensitivity to that environment, a sensitivity that has evolved in organisms, and that might be designed into buildings. This sensitivity contributes to the engagement of the agent in a coupling with its environment. A coupling is reciprocal, affecting both agent and environment. We can see now how a building acts through its movements. *Hyposurface* moves as an undulating surface, in a characteristic *Hyposurface* way. Consequently, it relates to onlookers and passers-by, coupling itself to a dynamic environment. The roof of the *Wacoal-Riccar Pavilion* expresses itself in a particular high-inertia wobble that is established in a coupling with the flow of air around it. And *Dottikon* moves in a way designed to affect visitors with an orchestrated chaos.

The concept of exteriorisation provides for cognition to be located, in part, outside the bounds of an agent's body. As such, buildings can be said to mediate a coupling between the occupant and its environment. The movements that have a building acting itself out, and that couple it to an environment, particularise this mediation. In this way, *Blur Building* could be seen to establish a coupling between visitors of the pavilion and the lakeside environment, sensitising visitors to parameters such as dew-point and convection. *Room Vehicle* is sensitive to the residential needs of its occupants, literally turning the house upside down and replacing constancy of the building with that of the occupant–environment relation.

Through the intimate process of designing and making, *Envir(On)ment* has clarified how movement can be sensitive to its environment, either driven from within, or actuated by external influences. It has clarified how an architecture of movement establishes active processes of engagement in a field of agency, where mutual couplings emerge between occupant, environment, and building—an architecture where movement gives rise to specific building cognition.

## What Might Enactive Architecture Look Like?

An obvious question is: What might enactive architecture look like? Without completing a process of design, no obvious answer

to that question can be provided. A first pointer is the research prototype described in chapter 4 as *Envir()nment*. Although the research prototype set out to speculate on a possibility—for an architecture of movement—it has been interpreted as a proposal for a building envelope in the context of a spin-off project. Given the approach to the design and the background of the designer, this might not be surprising, but there are significant limitations to the strips' functioning as a roof or facade. What we can take from *Envir()nment* is an approach to movement as constitutive of an architectural space, and designed to be sensitive to certain aspects of its environment. In the case of *Envir()nment*, such movement is driven by internal as well as external forces, but we should not be guided by its particular manifestation for a general characteristic of enactive architecture.

A second pointer is provided in this thesis in works that were not designed by the author but were described and analysed. To reiterate the previous point, these works demonstrate significant diversity in their physical appearance and in the manifestation of movement. The three aspects of enactive cognition given prominence in this thesis—coupling, acting out, and exteriorisation—have been identified in all of these works. As mentioned at the start of chapter 4, more examples could have replaced the nine works. Some others that are mentioned more than once in this thesis are AL\_A's MPavilion, Antoni Crescenti's installations, or Shigeru Ban's Naked House.

Apparently contradictory to points made earlier in this thesis, enactive architecture might be manifested in certain aspects of a building, rather than present in the entire structure. In this sense, a facade might be enactive, for example, or an interior element such as a wall or ceiling. Such aspects could still be designed in integration with the rest of the building, but the claim that removing them would fundamentally change the building as a whole might not hold in those cases. The reality of building design is one of compromise, however, and the forces that drive the design and construction of buildings are often beyond the reach of designers.

## How Do We Design Enactive Architecture?

The implication of enactive architecture as it is described in this thesis is that cognition is embodied by the building and enacted by its movements. The abstraction of cognition is given physical and concrete form in a particular architectural make-up. The idea of distributed active and embodied systems as a form or artificial intelligence is not a new idea per se. In the 1980s, Rodney Brooks developed robots designed that way and even before that time, John and Julia Frazer were integrating distributed forms of intelligence in building prototypes. However, enactive architecture does not insist on a broad general intelligence or complete cognition, rather it describes aspects of cognition attributable to buildings. It is suggested that enactive architecture as developed in this thesis

complements digital technologies and may work in conjunction with them.

It is through aspects such as material, geometry, layout, structure, and mechanism, that enactive architecture is shaped. These aspects are the territory of the building designer. Enactive architecture aspires to be available to the architects and engineers designing the built environment in particular, in order to promote integration of cognitive abilities in the structures forming the built environment. In this way, enactive cognitive abilities are placed amongst the competing concerns that pressure building designs and position designers to compose forms of cognition.

An approach to design of enactive architecture was described in chapter 3, albeit for a speculative scenario, and before the position was fully developed. A key factor in the design has been an extraordinary focus on movement. Where the notion of structured movement has been developed in this thesis to identify such movement in existing and past works of art and architecture, it could also be employed as design guidance. The three aspects of structured movement—intentional, actual, beyond utility—can become objectives in a process of design.

Intentionality of movement has been described referring to the design process. As design is now the starting point, intentionality should define what the movement should achieve. The role of movement is to act out an intrinsic quality of the building, a sensitivity to aspects of environment or occupancy. Movement also has a role in coupling the building to the environment and in mediating the coupling between the occupant and environment. Movement may affect the exteriorisation of memory in particular ways.

Actualisation of movement refers to it being out there in the world. The implications are that movement should be designed with attention to constructibility, economy, maintenance, and other factors that affect the realisation and longevity of the moving systems.

Beyond this, utility suggests a type of movement that is not merely functional. Given the approach to designing intentional movement, this objective might be already met. But the layering of functionality—utilitarian and beyond—may emphasise the significance of movement in a building. Chris van Duijn, a partner in OMA, insists that in their projects movement is at least functional (personal communication, 30 August 2017), and yet, buildings like the *Maison à Bordeaux*, *Fondation Galeries Lafayette*, and *Prada Transformer*, demonstrate a complexity of meaning that can be attributed largely to the movement they feature. In a practical context, such a layering that includes a primary utilitarian function might also ensure the realisation, and thus the actualisation of movement.

## Are Enactive Buildings Robots?

The theoretical position on building cognition proposed by this thesis, based on theories of enactive cognition and architectural movement, leaves us with an interesting question. Is designing architectural movement now the same as designing building cognition? Perhaps drawing a parallel between this and research by design would be expedient at this point. The question of whether all art constitutes research is addressed by Christopher Frayling in his paper about research through design and arts (Frayling, 1993). He responds that it depends on the goal of the process that is undertaken and writes: “We don’t want to be in a position where the entire history of art is eligible for a postgraduate research degree” (p. 5). Even though we might ascribe cognitive abilities to works that have not necessarily been designed for that purpose, not all designed movement would necessarily enable enactive architecture.

The movements that give rise to building cognition might well be described as robotic. They may be more or less functional, but their operations affect their context. The building may not be able to roam freely, but neither do all robots. The enactive view on cognition was supported by looking at the robots that were built following Rodney Brooks’ subsumption architecture. Embodied and distributed, those creatures would be active in a world and make sense of it on the move. This seemed a practical, engineering-led application of the starting points of enactivism.

In conclusion, the enactive view of buildings that is developed in this thesis could be understood to contribute to an enactive robotic approach to buildings. Given the available technology for movement in buildings, the building as a machine has become the building as a robot. As set out in section 4.8, however, robots do not typically provide for occupancy. They may be machines for interaction with people, but they are not designed for human inhabitation. Given the interest in this topic, as outlined in section 4.8, there seems little doubt that this will change, but, to date, little attention has been given to the significance of occupancy in the particular machine that is the robot. Enactive architecture addresses this aspect directly, by including the occupant in a cognitive framework for buildings.

A long history of architectural movement—including Roman ingenuity, dreams of reconfigurable cities, and a growing body of realised works of increasing sophistication—highlights an ongoing desire to integrate movement in the built environment. The trend of digitisation transforming many aspects of the built environment, including its operation, further highlights an ambition for buildings to become adept at optimising aspects of their performance, an optimisation that might employ architectural movement, and that ostensibly renders buildings intelligent or cognitive. The view presented in this thesis aims to build on these trends and aspirations, offering a view of building cognition that is designed to be inseparably part of buildings. In this view, cognition is acted out as architectural movement—it lets us dream of future buildings becoming cognitive as a result of their sensitivity to environment, and their sensitivity to being occupied.







# References

- Adrover, E. R. (2015). *Deployable Structures: Small architecture series*. London: Laurence King Publishing.
- Aish, R. (1986). Building modelling: the key to integrated construction CAD (Vol. 5, pp. 7–9). Presented at the CIB 5th International Symposium on the Use of Computers for Environmental Engineering Related to Buildings, Bath.
- Archer, B. (1979). Design as a Discipline. *Design Studies*, 1(1), 17–20.
- Archivio Gianni Colombo. (2018). Exhibitions. Retrieved March 22, 2018, from <http://www.archiviogiannicolombo.org/en/category/mostre-en/>
- Armstrong, A., Buffoni, G., Eames, D., James, R., Lang, L., Lyle, J., & Xuereb, K. (2013). The Al Bahar Towers: Multidisciplinary Design for Middle East High-Rise. (D. Brown, Ed.) *Arup Journal*, 2/2013, 60–73.
- Augusto, J. C., Callaghan, V., Cook, D., Kameas, A., & Satoh, I. (2013). “Intelligent Environments: a manifesto.” *Human-Centric Computing and Information Sciences*, 3(1), 12. <http://doi.org/10.1186/2192-1962-3-12>
- Ayres, P. (2012). *Persistent Modelling: extending the role of architectural representation*. Routledge.
- Baker, L. (2014). *Temporary Architecture*. Salenstein: Braun Publishing AG.
- Balmond, C. (1998). Number 9. Munich: Prestel.
- Balmond, C. (2007). *Informal*. Munich: Prestel.
- Bardi, L. B. (1993). Lina Bo Bardi. (M. C. Ferraz, Ed.). São Paulo: Instituto Lina Bo e P.M. Bardi.
- Bechtel, W., Abrahamsen, A., & Graham, G. (2001). Cognitive Science: History. In *International encyclopedia of the social & behavioral sciences* (pp. 2154–2158). Elsevier Amsterdam.
- Beesley, P. (2018). Precarious Living Reactions. In M. Daas & A. J. Wit (Eds.), *Towards a Robotic Architecture* (pp. 258–269). Novato, CA: Applied Research and Design Publishing.
- Best, S. (2012). *Vibration, Vibração, Vibración*. (L. Parker & A. Stephen, Eds.). University art Gallery, The University of Sydney.
- Beukers, A. (2005). *Lightness* (4 ed.). Rotterdam: 010 publishers.
- Bêka, I., & Lemoine, L. (2008). *Koolhaas Houselife [documentary film]*.
- Bêka, I., & Lemoine, L. (2013). *Koolhaas Houselife*. BêkaPartners.
- Bier, H. (2016). Robotic Building as Integration of Design-to-Robotic-Production & Operation. *Next Generation Building*, 3(1).

- Bier, H. H., & Mostafavi, S. (2016). Robotic Building as Physically Built Robotic Environments and Robotically Supported Building Processes. In N. S. Dalton, H. Schnädelbach, M. Wiberg, & T. Varoudis (Eds.), *Architecture and Interaction* (pp. 253–271). Springer.
- Biln, J. (2010). Reconsidering Agency in Architecture: A Late Review of Richard Serra's Railroad Turnbridge. *Architectural Theory Review*, 15(1), 1–8.
- Bishop, J. M., & Nasuto, J. S. (2005). Second-order cybernetics and enactive perception. *Kybernetes*, 34(9/10), 1309–1320. <http://doi.org/10.1108/03684920510614696>
- Blanchard, D. (1890, October 28). Tornado-Proof Building. Retrieved from <https://patents.google.com/patent/US439376A/en>
- Blundell Jones, P., & Meagher, M. (Eds.). (2015). *Architecture and Movement: the Dynamic Experience of Buildings and Landscapes*. Routledge.
- Bois, Y.-A. (2000). Force fields: phases of the kinetic. *Artforum*, 39(3), 145–146.
- Bony, P. (1987). *Les Diaphragmes de L'I.M.A.* [documentary film]. Gresh Productions.
- Brandt, J. (2012). The death of determinism. In *Persistent Modelling: extending the role of architectural representation* (pp. 105–116). Routledge.
- Brier, S. (1996). From second-order cybernetics to cybersemiotics: A semiotic re-entry into the second-order cybernetics of Heinz von Foerster. *Systems Research*, 13(3), 229–244. [http://doi.org/10.1002/\(SICI\)1099-1735\(199609\)13:3<229::AID-SRES96>3.0.CO;2-B](http://doi.org/10.1002/(SICI)1099-1735(199609)13:3<229::AID-SRES96>3.0.CO;2-B)
- Brooks, R. A. (1986). A robust layered control system for a mobile robot. *IEEE Journal on Robotics and Automation*, 2(1), 14–23. <http://doi.org/10.1109/JRA.1986.1087032>
- Brooks, R. A. (1991). Intelligence without representation. *Artificial Intelligence*, 47(1-3), 139–159. [http://doi.org/10.1016/0004-3702\(91\)90053-M](http://doi.org/10.1016/0004-3702(91)90053-M)
- Bruner, J. S. (1964). The course of cognitive growth. *American Psychologist*, 19(1), 1.
- Buckman, A. H., Mayfield, M., & Beck, S. B. M. (2014). What is a smart building? *Smart and Sustainable Built Environment*, 3(2), 92–109.
- Buckman, A. H., Mayfield, M., Meijer, R., & Beck, S. B. M. (2013). *Progressing for Intelligent to Smart Buildings*.
- Built Environment. (n.d.-a). In *Designing Buildings Wiki*. Retrieved September 1, 2017, from [https://www.designingbuildings.co.uk/wiki/Built\\_environment](https://www.designingbuildings.co.uk/wiki/Built_environment)

- Built Environment. (n.d.-b). In Oxford Dictionary of English Online. Retrieved September 1, 2017, from [https://en.oxforddictionaries.com/definition/built\\_environment](https://en.oxforddictionaries.com/definition/built_environment)
- Built Environment. (n.d.-c). In Wikipedia. Retrieved September 1, 2017, from [https://en.wikipedia.org/wiki/Built\\_environment](https://en.wikipedia.org/wiki/Built_environment)
- Burry, J. (2013). *Designing the Dynamic*. Melbourne Books.
- Burry, M. (2016). Antoni Gaudí and Frei Otto: Essential Precursors to the Parametricism Manifesto. *Architectural Design*, 86(2), 30–35. <http://doi.org/10.1002/ad.2021>
- Burry, M., & Burry, J. (2016). *Prototyping for Architects*. Thames & Hudson Limited.
- Burton, M. (2006). *Effects of Low Frequency Wind-Induced Building Motion on Occupant Comfort (PhD thesis)*. Hong Kong University of Science and Technology, Hong Kong.
- Calder, A., & Saraiva, R. (2006). *Calder no Brasil: Crônica de uma Amizade*. (R. Saraiva, Ed.). CosacNaify.
- Callaghan, V., Clarke, G., Pounds-Cornish, A., & Sharples, S. (2000). Buildings as intelligent autonomous systems: a model for integrating personal and building agents (pp. 410–415). Presented at the The 6th International Conference on Intelligent Autonomous Systems (IAS-6).
- Candy, L., & Edmonds, E. (2010). The Role of the Artefact and Frameworks for Practice-based Research. In M. Biggs & H. Karlsson (Eds.), *The Routledge Companion To Research In The Arts* (pp. 120–137). Routledge.
- Castilla, N. (2013). *Greenhouse Technology and Management*. Cabi.
- Chalcraft, E. (2012, October 30). RV Prototype (RV = Room Vehicle) by Greg Lynn. Retrieved October 4, 2017, from <https://www.dezeen.com/2012/10/30/rv-room-vehicle-by-greg-lynn/>
- Chemero, A. (2011). *Radical embodied cognitive science*. MIT Press.
- Clark, A., & Chalmers, D. (1998). The extended mind. *Analysis*, 7–19. Retrieved from <https://academic.oup.com/analysis/article/58/1/7/153111>
- Colombetti, G. (2015). Enactive Affectivity, Extended. *Topoi*, 36(3), 445–455. <http://doi.org/10.1007/s11245-015-9335-2>
- Cook, P. (2014). *Drawing: The Motive Force of Architecture*. Chichester, UK: Wiley. <http://doi.org/10.1002/9781118827543>
- Covestro. (2017). *Makrolon® UV*. Leverkusen: Covestro Deutschland AG.
- Cross, N. (1982). Designerly ways of knowing. *Design Studies*, 3(4), 221–227. [http://doi.org/10.1016/0142-694X\(82\)90040-0](http://doi.org/10.1016/0142-694X(82)90040-0)
- Daas, M., & Wit, A. J. (Eds.). (2018). *Towards a Robotic Architecture*. Novato, CA: Applied Research and Design Publishing.

- Davidson, C. C., Anyone Corporation. (1996). *Anywise*. (C. C. Davidson, Ed.). New York: The MIT Press.
- Davis, D. (2013). *Modelled on Software Engineering: Flexible Parametric Models in the Practice of Architecture (PhD thesis)*. School of Architecture and Design, College of Design and Social context, RMIT University.
- De Haan, J. (1996). The Most Interesting Thing About Architecture is Arriving in New Worlds Rather than Returning to Old Ones: Interview with Rem Koolhaas. Retrieved 2017, from <http://www.jasperdehaanarchitecten.nl/en/jasper-de-haan-architects/writings/interview-with-rem-koolhaas.aspx>
- De Walsche, J., & Komossa, S. (Eds.). (2016). *Prototypes and paradigms: Architectural research vis-à-vis research-by-design*. TU Delft Open.
- Design Research Society. (2017). DRS: History. Retrieved August 7, 2017, from <http://www.designresearchsociety.org/cpages/history>
- Di Paolo, E. (2008). Extended Life. *Topoi*, 28(1), 9–21. <http://doi.org/10.1007/s11245-008-9042-3>
- Diller, E. (2008). Liz Diller: Architecture is a special effects machine [lecture]. *EG Conference 2007*. Retrieved from <https://www.youtube.com/watch?v=hB6ZbC53tVc>
- Diller, E., & Scofidio, R. (2002). *Blur: the making of nothing*. Harry N. Abrams.
- Dimendberg, E. (2013). *Diller Scofidio + Renfro: Architecture After Images*. University of Chicago Press.
- Durand, L. (2015). *IMA: Ingénierie de Restauration des Moucharabiehs APD*. Avignon.
- Eastman, C., Teicholz, P., Sacks, R., & Liston, K. (2008). *BIM Handbook*. Hoboken, NJ, USA: John Wiley & Sons, Inc. <http://doi.org/10.1002/9780470261309>
- Ehrmann, W. (Ed.). (1975). *Gianni Colombo: Kinetische Objekte Strukturen und Räume*. Städtisches Museum Leverkusen Schloß Morsbroich.
- Einstein, A. (1936). Physics and Reality. *Journal of the Franklin Institute*, 221(3), 349–382. [http://doi.org/10.1016/S0016-0032\(36\)91047-5](http://doi.org/10.1016/S0016-0032(36)91047-5)
- Eliasmith, C., Stewart, T. C., Choo, X., Bekolay, T., DeWolf, T., Tang, Y., & Rasmussen, D. (2012). A large-scale model of the functioning brain. *Science*, 338(6111), 1202–1205.
- Ellis, A., Hunt, E., & Johnson-Laird, P. N. (1985). *The Blackwell dictionary of cognitive psychology*. (M. W. Eysenck, Ed.). Blackwell Publishing.
- Emery, M. (Ed.). (1980, December). Le Premier Batiment “Intelligent.” *L’Architecture D’Aujourd’hui*, (212), 14–15.

- Exploratorium. (2016). Strandbeest: The Dream Machines of Theo Jansen with photography by Lena Herzog. Retrieved April 7, 2018, from [www.exploratorium.edu/strandbeest](http://www.exploratorium.edu/strandbeest)
- Fayat, C. (Ed.). (2010, October 5). MANIFESTE 2010. Retrieved February 15, 2018, from <http://www.arsindustrialis.org/manifeste-2010>
- Fodor, J. A. (1983). *The modularity of mind: An essay on faculty psychology*. MIT Press.
- Fodor, J. A., & Pylyshyn, Z. W. (1988). Connectionism and cognitive architecture: A critical analysis. *Cognition*, 28(1), 3–71.
- Foerster, Von, H. (2003). Cybernetics of cybernetics. *Understanding Understanding: Essays on Cybernetics and Cognition*, 283–286.
- Fox, M. (2016). *Interactive Architecture: Adaptive World*. Princeton Architectural Press.
- Fox, M. A. (n.d.). Robotecture. Retrieved September 28, 2017, from <http://robotecture.com/>
- Franzen, U., & Hejduk, J. (1971). *Education of an architect: a point of view*.
- Fraser, M. (Ed.). (2013). *Design Research in Architecture: An Overview*. Ashgate Publishing, Ltd.
- Frayling, C. (1993). Research in Art and Design. *Royal College of Art Research Papers*, 1(1).
- Froese, T., & Ziemke, T. (2009). Enactive artificial intelligence: Investigating the systemic organization of life and mind. *Artificial Intelligence*, 173(3-4), 466–500. <http://doi.org/10.1016/j.artint.2008.12.001>
- Furtado C L, G. M. (2008). Cedric Price's Generator and the Frazers' systems research. *Technoetic Arts: a Journal of Speculative Research*, 6(1), 55–72. <http://doi.org/10.1386/tear.6.1.55/1>
- Gallagher, S. (2009). Philosophical Antecedents of Situated Cognition. In M. Aydede & P. Robbins (Eds.), *The Cambridge handbook of situated cognition* (pp. 35–53). Cambridge: Cambridge University Press.
- Generator, Floride, USA. (1980, December). Generator, Floride, USA. *L'Architecture D'Aujourd'hui*, (212), 14–15.
- Gibson, J. J. (2014). *The Ecological Approach to Visual Perception: Classic Edition*. Psychology Press.
- Giedion, S. (1959). *Space, Time and Architecture* (3rd ed.). Cambridge, MA: Harvard University Press.
- Goldstein, K. (1934). *Der Aufbau der Organismus*. Dordrecht: Springer-Science+Business Media, B.V.
- Goldstein, K. (1995). *The organism: a holistic approach to biology derived from pathological data in man*. New York: Zone Books.



- González, J. (1998). Installation Art. In M. Kelly (Ed.), *Encyclopedia of Aesthetics* (Vol. 2, pp. 503–508). Encyclopedia of Aesthetics.
- Goodfellow, I., Bengio, Y., & Courville, A. (2016). *Deep Learning*. MIT Press.
- Goulthorpe, M. (1999). Aegis Hyposurface. In S. Perrella (Ed.), *Architectural Design: Hypersurface architecture II* (pp. 60–65). Academy Editions.
- Goulthorpe, M. (2009). *The Possibility of (an) Architecture: Collected Essays by Mark Goulthorpe*, DECOi Architects. Taylor & Francis.
- Goulthorpe, M., Burry, M., & Dunlop, G. (2001). Aegis Hyposurface: The Bordering of University and Practice (pp. 344–349). Presented at the Reinventing the Discourse - How Digital Tools Help Bridge and Transform Research, Education and Practice in Architecture: Proceedings of the Twenty First Annual Conference of the Association for Computer-Aided Design in Architecture, Buffalo (New York).
- Graefe, R., Hennicke, J., Kugel, F., Pankoke, U., Otto, F., Schock, H.-J., & Blumel, J. W. D. (1972). IL 5 Wandelbare Dacher Convertible Roofs. Institute for Lightweight Structures.
- Green, K. E. (2016). *Architectural Robotics: Ecosystems of Bits, Bytes, and Biology*. MIT Press.
- Groák, S. (1992). *The Idea of Building: Thought and Action in the Design and Production of Buildings*. London, New York: E & FN Spon.
- Gross, M. D., & Green, K. E. (2012). Architectural robotics, inevitably. *Interactions*, 19(1), 28–33. <http://doi.org/10.1145/2065327.2065335>
- Hagras, H., Callaghan, V., Colley, M., Clarke, G., Pounds-Cornish, A., & Duman, H. (2004). Creating an ambient-intelligence environment using embedded agents. *IEEE Intelligent Systems*, 19(6), 12–20.
- Hale, J. (2016). *Merleau-Ponty for architects*. Routledge.
- Hale, K. S., & Stanney, K. M. (2014). *Handbook of Virtual Environments: Design, Implementation, and Applications* (2nd ed.). Boca Raton, FL, USA: CRC Press, Inc.
- Hegger, M., Fafflok, C., Hegger, J., & Passig, I. (2016). *Aktivhaus- The Reference Work: From Passivhaus to Energy-Plus House*. Birkhäuser.
- Hill, C. S. (2016). *This is Temporary: How Transient Projects are Redefining Architecture*. Riba Publishing.
- Hill, J. (2013). Design Research: The First 500 Years. In M. Fraser (Ed.), *Design Research in Architecture: An Overview* (pp. 15–34). Ashgate Publishing, Ltd.
- Hurley, S. (2001). Perception, Action and Consciousness || Perception and Action: Alternative Views. *Synthese*, 129, 3–40. <http://doi.org/10.2307/20117165>

- Hutto, D. D., Kirchhoff, M. D., & Myin, E. (2014). Extensive enactivism: why keep it all in? *Frontiers in Human Neuroscience*, 8, 43. <http://doi.org/10.3389/fnhum.2014.00706>
- HypoSurface Corp. (2008, December 24). [www.hyposurface.org](http://www.hyposurface.org). Retrieved August 7, 2017, from <http://www.hyposurface.org/>
- IBA Hamburg GmbH. (2013). *Smart Material House | Soft House*. Hamburg: IBA Hamburg GmbH. Retrieved from <https://www.iba-hamburg.de/en/themes-projects/the-building-exhibition-within-the-building-exhibition/smart-material-houses/soft-house/projekt/soft-house.html>
- Incerti, G., Ricchi, D., & Simpson, D. (2007). Diller + Scofidio (+ Renfro), *The Ciliary Function: works and projects, 1979-2007*. Skira.
- Institut du Monde Arabe. (2016, May 30). History. Retrieved August 8, 2017, from <https://www.imarabe.org/en/missions-operations/history>
- Intille, S. S., Larson, K., Beaudin, J., Tapia, E. M., Kaushik, P., Nawyn, J., & McLeish, T. J. (2005). *The PlaceLab: A live-in laboratory for pervasive computing research [video]*. *Proceedings of PERVASIVE 2005 Video Program*.
- Ishii, K. (2000). *Structural Design of Retractable Roof Structures*. WIT Press.
- Jacques, M. (Ed.). (1998). *OMA Rem Koolhaas: Living, Vivre, Leben*. Bordeaux, France: Arc en Rêve Centre d'Architecture Birkhäuser Verlag.
- Japan Association for the 1970 World Exposition. (2006). 公式記録映画 日本万国博 (*Official Recording of the World Exhibition in Japan*) [*documentary video*]. Geneon Entertainment.
- Jeanneret, P., Le Corbusier. (1937). *Oeuvre complète 1910-1929* (Vol. 1). Zurich: Editions Dr. H. Girsberger.
- Johnston, J. (2008). *The Allure of Machinic Life: Cybernetics, Artificial Life, and the New AI*. MIT Press.
- Jones, G. M., & Young, L. R. (1978). Subjective Detection Of Vertical Acceleration: A Velocity-Dependent Response? *Acta Oto-Laryngologica*, 85(1-6), 45-53. <http://doi.org/10.3109/00016487809121422>
- Joost, G., Bredies, K., Christensen, M., Conradi, F., & Unteidig, A. (Eds.). (2016). *Design as Research: Positions, Arguments, Perspectives*. Birkhäuser.
- Jormakka, K. (2002). Moving on. In *Absolute Motion* (pp. 90-107). Tampere University of Technology.
- Joselit, D. (2013). *After Art*. Princeton University Press.
- Kalay, Y. E. (2004). *Architecture's New Media: Principles, Theories, and Methods of Computer-aided Design*. MIT Press.

- Kaschak, M. P., & Glenberg, A. M. (2000). Constructing Meaning: The Role of Affordances and Grammatical Constructions in Sentence Comprehension. *Journal of Memory and Language*, 43. <http://doi.org/10.1006/jmla.2000.2705>
- Kelly, K. (1994). *Out of Control: The Rise of Neo-Biological Civilization*. Perseus Books.
- Kennedy, J., Eberhart, R. C., & Shi, Y. (2001). *Swarm intelligence*. Elsevier.
- Kepes, G. (1965). *The Nature and Art of Motion*. (G. Kepes, Ed.). New York: George Braziller Inc.
- Kieckhefer, R. (2008). *Theology in stone: Church architecture from Byzantium to Berkeley*. Oxford University Press.
- Klein, P. D. (1997). Multiplying the Problems of Intelligence by Eight: A Critique of Gardner's Theory. *Canadian Journal of Education / Revue Canadienne De L'éducation*, 22(4), 377. <http://doi.org/10.2307/1585790>
- Knippers, J., & Speck, T. (2012). Design and construction principles in nature and architecture. *Bioinspiration & Biomimetics*, 7(1), 015002.
- Kolarevic, B. (2009). Exploring Architecture of Change (pp. 58–61). Presented at the reForm() - Building a Better Tomorrow: Proceedings of the 29th Annual Conference of the Association for Computer Aided Design in Architecture (ACADIA), Chicago, Illinois: The School of the Art Institute of Chicago.
- Kolarevic, B. (2015). Towards Architecture of Change. In V. Parlac (Ed.), *Building Dynamics: Exploring Architecture of Change* (pp. 1–16). Taylor & Francis.
- Kolarevic, B., & Malkawi, A. (2005). *Performative Architecture: Beyond Instrumentality*. Spon Press.
- Kolarevic, B., & Parlac, V. (2015). *Building Dynamics: Exploring Architecture of Change*. Taylor & Francis.
- Komatsu, T. (Ed.). (1969). *Expo'70 News* (Vol. 4). Japan Association for the 1970 World Exposition.
- Koolhaas, R. (1978). *Delirious New York: A Retroactive Manifesto for Manhattan*. Oxford University Press.
- Kroes, P. (1996). *Idealbeelden van wetenschap: een inleiding tot de wetenschapsfilosofie*. Amsterdam: Boom.
- Kronenburg, R. (1998). *Ephemeral/portable architecture. Architectural Design Profile*. (Vol. 68). John Wiley & Sons.
- Kronenburg, R. (2003). *Portable Architecture*. Routledge.
- Kronenburg, R. (2007). *Flexible: Architecture that Responds to Change*. London: Laurence King Publishing.
- Kronenburg, R. (2013a). *Architecture in Motion: The History and Development of Portable Building*. Routledge.

- Kronenburg, R. (2013b). *Transportable Environments*. Taylor & Francis.
- Kronenburg, R., & Klassen, F. (2006). *Transportable Environments 3*. Taylor & Francis.
- Kuhn, T. S. (1962). *The Structure of Scientific Revolutions*. University of Chicago Press.
- Lakoff, G., & Johnson, M. (1980). *Metaphors we live by*. Chicago: The University of Chicago.
- Lampariello, B. (2011). *Villa a Floirac*. Aracne Editrice S.r.l.
- Lawson, B. D., & Riecke, B. E. (2014). Perception of Body Motion. In *Handbook of Virtual Environments: Design, Implementation, and Applications* (pp. 163–195). Boca Raton, FL, USA: CRC Press, Inc.
- Le Corbusier. (1924). *Vers une Architecture* (2nd ed.). Paris: Les Editions G. Crès et Cie.
- Levene, R. C., & Márquez Cecilia, F. (Eds.). (1996). *OMA/Rem Koolhaas, 1992-1996*. Madrid: El Croquis.
- Liddell, I. (2015). Frei Otto and the development of gridshells. *Case Studies in Structural Engineering*, 4, 39–49. <http://doi.org/10.1016/j.csse.2015.08.001>
- Lim, Y.-K., Stolterman, E., & Tenenberg, J. (2008). The anatomy of prototypes: Prototypes as filters, prototypes as manifestations of design ideas. *ACM Trans. Comput.-Hum. Interact.*, 15(2), 7–27. <http://doi.org/10.1145/1375761.1375762>
- Linn, C., & Fortmeyer, R. (2014). *Kinetic Architecture: Design for Active Envelopes*. Images Publishing.
- Love, T. (2003). Kit-of-Parts Conceptualism. *Harvard Design Magazine*, (Fall).
- Lynn, G. (1998). *Animate Form*. New York: Princeton Architectural Press.
- Lynn, G. (2012). RV Prototype. Retrieved October 4, 2017, from <http://www.glform.com/robot/rvprototype/animation/>
- Lynn, G. (2014a). GREG LYNN ROBOT – WHY MOVE NOW? Retrieved October 26, 2016, from <http://www.glform.com/robot/why-move-now/>
- Lynn, G. (2014b). RV (Room Vehicle) Prototype: Where the Surface meets the Machine. *Inflexions*, 7(Animating Biophilosophy), 184–186. Retrieved from [www.inflexions.org](http://www.inflexions.org)
- Lynn, G., & Goulthorpe, M. (2014). HypoSurface [electronic resource]. *Archaeology of the Digital*. (G. Lynn, Ed.) (Vol. 6). Montréal: Canadian Centre for Architecture.
- Markram, H. (2006). The Blue Brain Project. *Nature Reviews Neuroscience*, 7(2), 153–160.
- Marotta, A. (2011). *Diller + Scofidio: Blurred Theater*. Edilstampa editrice dell'ANCE.

- Martins, S. B. (2016). Wind Chimes of Modernity: Calder's 1948 Trip to Brazil. In A. Borchardt-Hume (Ed.), *Alexander Calder: Performing Sculpture*. London: Tate Publishing.
- Mataric, M. J. (2007). *The Robotics Primer*. MIT Press.
- Maturana, H. R., & Varela, F. J. (1980). *Autopoiesis and Cognition: The Realization of the Living* (1st ed.). D. Reidel Publishing Company.
- Maturana, H. R., & Varela, F. J. (1992). *The Tree of Knowledge: The Biological Roots of Human Understanding* (Rev Sub). Shambhala.
- McCarter, R. (Ed.). (1987). *Pamphlet Architecture 12: Building; Machines*. Princeton Architectural Press.
- McCauley, M. (2010). AccelStepper [software]. AirSpayce Pty Ltd. Retrieved from <http://www.airspayce.com/mikem/arduino/AccelStepper/>
- McCulloch, W. S., & Pitts, W. (1943). A logical calculus of the ideas immanent in nervous activity. *The Bulletin of Mathematical Biophysics*, 5(4), 115–133.
- McDermon, D. (2017, June 26). Bringing Alexander Calder's Sculptures to Life. Retrieved November 13, 2017, from <https://www.nytimes.com/interactive/2017/06/26/arts/whitney-museum-alexander-calder-exhibition.html>
- McGee, W., Velikov, K., Thün, G., & Tish, D. (2018). Prologue for a Robotic Architecture. In M. Daas & A. J. Wit (Eds.), *Towards a Robotic Architecture* (pp. 190–203). Novato, CA: Applied Research and Design Publishing.
- Menary, R. (2010). Introduction to the special issue on 4E cognition. *Phenomenology and the Cognitive Sciences*, 9(4), 459–463.
- Merleau-Ponty, M. (1964). *The primacy of perception: and other essays on phenomenological psychology, the philosophy of art, history, and politics*. (J. M. Edie, Ed.). Northwestern University Press.
- Merleau-Ponty, M. (1967). *The Structure of Behaviour*. (A. L. Fisher, Trans.). London: Beacon Press.
- Merleau-Ponty, M. (2012). *Phenomenology of perception*. Routledge.
- Michelson, A., Serra, R., & Weyergraf, C. (1979). The Films of Richard Serra: An Interview. *October*, 10, 69–104.
- Moloney, J. (2011). *Designing Kinetics for Architectural Facades: State Change*. Taylor & Francis.
- Moloney, J., Smitheram, J., & Twose, S. (Eds.). (2015). *Perspectives on Architectural Design Research: What Matters - Who Cares - How*. Spurbuchverlag.
- Morgan, C. L. (1998). *Jean Nouvel: the elements of architecture*. Thames & Hudson.

- Museo del Novecento - restauratori e restauri in museo. (2014).  
 Museo del Novecento - restauratori e restauri in museo.  
 Retrieved October 7, 2017, from <http://www.rrmusei.it/en/musei-e-opere/museo-del-novecento/>
- Nakamura, T. (1970). Wacoal-Riccar News: The Pavilion of Wacoal-Riccar Sewing Machine EXPO '70. The Pavilion of Wacoal-Riccar Sewing Machine Secretariat.
- Nakaya, F. (1972). Making of "Fog" or Low-Hanging Stratus Cloud. In B. Klüver, J. Martin, & B. Rose (Eds.), *Pavilion* (pp. 207–223). New York: E.P. Dutton & Co., Inc.
- Negendahl, K. (2015). Building performance simulation in the early design stage: An introduction to integrated dynamic models. *Automation in Construction*, 54, 39–53. <http://doi.org/10.1016/j.autcon.2015.03.002>
- Negroponte, N. (1970). *The architecture machine*. MIT press.
- Negroponte, N. (1975). *Soft architecture machines*. The MIT Press.
- Newell, A., & Simon, H. A. (1972). *Human problem solving* (Vol. 104). Englewood Cliffs, NJ: Prentice-Hall.
- Newell, A., Shaw, J. C., & Simon, H. A. (1959). Report on a general problem solving program (Vol. 256, p. 64). Presented at the IFIP congress.
- Newman, D. (2008, July 20). That Squiggle of the Design Process. Retrieved April 6, 2018, from <https://web.archive.org/web/20081120061039/http://centralstory.com/filed/squiggle/>
- Next Office. (2014). Sharifi-ha House | Next Office. Retrieved April 3, 2016, from <http://nextoffice.ir/\#!/project/sharifi-ha-house/>
- Nihon Bankoku Hakurankai Kyokai. (1972). *Japan World Exposition, Osaka, 1970, official report* (Vol. 1). Osaka: Commemorative Association for the Japan World Exposition (1970).
- Nilsson, N. J. (1984). *Shakey the Robot: Technical Note 323* (p. 139). Menlo Park: Artificial Intelligence Center, SRI International.
- Noë, A. (2004a). *Action in Perception*. MIT Press.
- Noë, A. (2004b). Pictures in Mind. In *Action in Perception* (pp. 35–73). MIT Press.
- Noë, A. (2015). *Strange Tools: Art and Human Nature*. Farrar, Straus and Giroux.
- Noë, A., & O'Regan, J. K. (2002). On the Brain-Basis of Visual Consciousness: A Sensorimotor Account. In A. Noë & E. Thompson (Eds.), *Vision and Mind: Selected Readings in the Philosophy of Perception*. The MIT Press.
- O'Regan, J. K. (1992). Solving the "real" mysteries of visual perception: The world as an outside memory. *Canadian Journal of Psychology / Revue Canadienne De Psychologie*, 46. <http://doi.org/10.1037/h0084327>

- O'Regan, J. K., & Noë, A. (2001). A sensorimotor account of vision and visual consciousness. *Behavioral and Brain Sciences*, 24(5), 939–973.
- Oborn, P., Heathcote, E., Denison, E., & Ormsby, E. (2013). *Al Bahr towers: the Abu Dhabi investment council headquarters*. Wiley.
- Oosterhuis, K. (2005). A new kind of building. In G. Flachbart & P. Weibel (Eds.), *Disappearing architecture from real to virtual to quantum* (pp. 90–118).
- Otto, F. (2017). *Frei Otto: Thinking by Modeling*. (G. Vrachliotis, Ed.). Leipzig: Spector Books.
- Oungrinis, K.-A., & Liapi, M. (2014). Spatial Elements Imbued with Cognition: A possible step toward the “Architecture Machine.” *International Journal of Architectural Computing*, 12(4), 419–438. <http://doi.org/10.1260/1478-0771.12.4.419>
- Pask, G. (1969). The architectural relevance of cybernetics. *Architectural Design*, 9(69), 494–496.
- Pellegrino, S. (2001). *Deployable Structures*. (S. Pellegrino, Ed.). Vienna: Springer Vienna. <http://doi.org/10.1007/978-3-7091-2584-7>
- Perlin, K. (1985). An image synthesizer. *ACM Siggraph Computer Graphics*, 19(3), 287–296.
- Perrella, S. (Ed.). (1998). *Architectural Design: Hypersurface Architecture*. Academy Editions.
- Perrella, S. (Ed.). (1999). *Architectural Design: Hypersurface architecture II*. Academy Editions.
- Petersen, A. R. (2015). *Installation Art*. Museum Tusulanum Press.
- Pfeifer, R., & Scheier, C. (2001). *Understanding intelligence*. MIT Press.
- Pitt, D. (2017). Mental Representation. In E. N. Zalta (Ed.), *The Stanford Encyclopedia of Philosophy* (2017 ed.). Metaphysics Research Lab, Stanford University.
- Poincaré, H., & Halsted, G. B. (1913). *The Foundations of Science: Science and Hypothesis, The Value of Science, Science and Method*. Science Press.
- Poirier, M. (2016). Perception. In T. Colstrup, L. R. Jørgensen, M. Juul Holm, & K. Degel (Eds.), *Eye Attack: Op Art and Kinetic Art 1950-1970*. Louisiana Museum of Modern Art.
- Pola, F., & Scotini, M. (Eds.). (2015). *Gianni Colombo: the body and the space 1959 - 1980*. Marsilio.
- Popper, F. (1968). *Origins and development of kinetic art*. (S. Bann, Trans.). London: Studio Vista Limited.
- Posner, M. I. (Ed.). (1989). *Foundations of Cognitive Science*. Cambridge, MA, USA: MIT Press.

- Poulsgaard, K. S. (2017). Enactive individuation: technics, temporality and affect in digital design and fabrication. *Phenomenology and the Cognitive Sciences*, 4(1), 78. <http://doi.org/10.1007/s11097-017-9539-6>
- Quartz, S. R., & Sejnowski, T. J. (1997). The neural basis of cognitive development: A constructivist manifesto. *Behavioral and Brain Sciences*, 20(4), 537–556.
- Randl, C. (2008). *Revolving Architecture: A History of Buildings That Rotate, Swivel, and Pivot*. Princeton Architectural Press.
- Reveley, J., & Peters, M. A. (2016). Mind the gap: infilling Stiegler's philosophico-educational approach to social innovation. *Educational Philosophy and Theory*, 48(14), 1452–1463. <http://doi.org/10.1080/00131857.2016.1155433>
- Rickey, G. W. (1963). The morphology of movement: a study of kinetic art. *Art Journal*, 22(4), 220–231. <http://doi.org/https://doi.org/10.1080/00043249.1963.10794433>
- Rietveld, E. (2016). Situating the Embodied Mind in a Landscape of Standing Affordances for Living Without Chairs: Materializing a Philosophical Worldview. *Sports Medicine (Auckland, N.Z.)*, 46, 927–932.
- Rietveld, E., & Kiverstein, J. (2014). A rich landscape of affordances. *Ecological Psychology*, 26(4), 325–352.
- Robbins, P. (2017). Modularity of Mind. In E. N. Zalta (Ed.), *The Stanford Encyclopedia of Philosophy* (2017 ed.). Metaphysics Research Lab, Stanford University.
- Robbins, P., & Aydede, M. (2009). *The Cambridge handbook of situated cognition*. Cambridge: Cambridge University Press.
- Rowlands, M. (2010). *The New Science of the Mind*. The MIT Press. <http://doi.org/10.7551/mitpress/9780262014557.001.0001>
- Rumelhart, D. E., & McClelland, J. L. (1986). *Parallel distributed processing: Explorations in the microstructures of cognition. Volume 1: Foundations*. The MIT Press, Cambridge, MA.
- Russell, S. J., & Norvig, P. (2010). *Artificial intelligence: a modern approach*. (P. Norvig, Ed.). Pearson Education, Limited.
- Rutten, D. (2007). Grasshopper [software]. Robert McNeel & Associates. Retrieved from <https://www.rhino3d.com>
- Saffiotti, A., Broxvall, M., Gritti, M., LeBlanc, K., Lundh, R., Rashid, J., et al. (2008). The PEIS-ecology project: vision and results (pp. 2329–2335). Presented at the Intelligent Robots and Systems, 2008. IROS 2008. IEEE/RSJ International Conference on.
- Salim, F. (2010). *Ubimash - Sensor data mashing for connecting physical devices and interfaces with virtual CAD applications [software]*.
- Salim, F. D., Mulder, H., & Burry, J. (2010a). A System For Form Fostering. Presented at the Proceedings of the 15th International Conference on Computer Aided Architectural Design Research in Asia, Hong Kong, China.



- Salim, F. D., Mulder, H., & Burry, J. (2011). Form Fostering: A Novel Design Approach for Interaction with Parametric Models in the Embodied Virtuality. *Journal of Information Technology in Construction*. Retrieved from [http://itcon.org/data/works/att/2011\\_9.content.02666.pdf](http://itcon.org/data/works/att/2011_9.content.02666.pdf)
- Salim, F. D., Mulder, H., Jaworski, P., Ransom, J. W., Cutellic, P., Iseki, T., et al. (2010b). Collaborative Design and Live Interaction with Parametric Models using UbiMash. *International Journal of Architectural Computing (IJAC)*, 8(3), 377–398.
- Salter, C. (2010). *Entangled: Technology and the Transformation of Performance*. MIT Press.
- Samuel, F. (2015). Architectural promenades through the Villa Savoye. In P. Blundell Jones & M. Maegher (Eds.), *Architecture and Movement: the Dynamic Experience of Buildings and Landscapes* (pp. 44–49). Routledge.
- Samuel, F., & Jones, P. B. (2012). The making of architectural promenade: Villa Savoye and Schminke House. *Architectural Research Quarterly*, 16(02), 108–124. <http://doi.org/10.1017/S1359135512000437>
- Sartre, J.-P. (1947). Existentialist on Mobilist; Calder's Newest Works Judged by France's Newest Philosopher. *Art News*, (XLVI), 22–23. Retrieved from <http://www.artnews.com/2017/06/30/from-the-archives-jean-paul-sartre-on-alexander-calder-in-1947/>
- Schafer, A. (2003). Designing Inefficiencies. In *Scanning: the Aberrant Architectures of Diller + Scofidio* (pp. 93–102). New York: Whitney Museum of American Art.
- Schlegel, A. (2011). controlP5: A GUI (graphical user interface) library for processing. [software]. Retrieved from <http://www.sojamo.de/libraries/controlP5/>
- Schumacher, M., Schaeffer, O., & Vogt, M.-M. (2010). *MOVE: Architecture in Motion - Dynamic Components and Elements*. Walter de Gruyter.
- Schumacher, P. (1996). The Architecture of Movement. *Arch+*, 134/135, 56–58.
- Schumacher, P. (2008). Parametricism as Style - Parametricist Manifesto. Retrieved July 5, 2016, from <http://www.patrikschumacher.com/Texts/Parametricism%20as%20Style.htm>
- Schwartz-Clauss, M. (2002). *Living in Motion: Design and Architecture for Flexible Dwelling*. Vitra Design Museum.
- Searle, J. R. (1980). Minds, brains, and programs. *Behavioral and Brain Sciences*, 3(3), 417–424.
- Selz, P. (1966). *Directions in Kinetic Sculpture*. University of California Press.
- Shankar, S. (2015). Living Root Bridges: State of knowledge, fundamental research and future application. *IABSE Symposium Report*, 105(4), 1–8.

- Shields, R. (2003). *The Virtual*. Routledge.
- Sibolboro, R., Designboom. (2012). *Greg Lynn speaks to Designboom about his primitives project "RV - room vehicle."* Designboom. Retrieved from <https://www.designboom.com/architecture/greg-lynn-rv-prototype-house/>
- Silver, D., Schrittwieser, J., Simonyan, K., Antonoglou, I., Huang, A., Guez, A., et al. (2017). Mastering the game of Go without human knowledge. *Nature*, 550(7676), 354–359. <http://doi.org/10.1038/nature24270>
- Simon, H. A. (1996). *The sciences of the artificial* (3rd ed.). Cambridge, MA: MIT Press.
- Simon, H. A., & Kaplan, C. A. (1989). Foundations of cognitive science. In M. I. Posner (Ed.), *Foundations of Cognitive Science* (pp. 1–47). Cambridge, MA, USA: MIT Press.
- Smith, B. C. (1999). Situatedness/embeddedness. *The MIT Encyclopedia of the Cognitive Sciences*, 769–770.
- So, A. T.-P., & Chan, W. L. (2012). *Intelligent Building Systems*. Springer US.
- Soar, R. (2016a). Part 1: A process view of nature. Multifunctional integration and the role of the construction agent. *Intelligent Buildings International*, 8(2), 78–89. <http://doi.org/10.1080/17508975.2015.1014460>
- Soar, R. (2016b). Part 2: Pushing the envelope. A process perspective for architecture, engineering and construction. *Intelligent Buildings International*, 8(2), 90–105. <http://doi.org/10.1080/17508975.2015.1014461>
- Songel, J. M. (2010). *A conversation with Frei Otto* (Reprint). Princeton Architectural Press.
- Speaks, M. (2002a). Design intelligence part 1: introduction. *A+U (Architecture and Urbanism)*, (387), 10–18.
- Speaks, M. (2002b). Design intelligence: or thinking after the end of metaphysics. *Architectural Design*, 72(5), 4–6.
- Speaks, M. (2006). Intelligence after theory. *Perspecta*, 38, 101–106.
- Stepperonline. (2017). *17HS24-2104S*. Stepperonline. Retrieved from <https://www.omc-stepperonline.com/download/17HS24-2104S.pdf>
- Sterk, T. D. (2003). Using Actuated Tensegrity Structures to Produce a Responsive Architecture (pp. 84–93). Presented at the ACADIA22: Connecting Crossroads of Digital Discourse.
- Stewart, J., Stewart, J. R., Gapenne, O., & Di Paolo, E. A. (2010). *Enaction: Toward a New Paradigm for Cognitive Science*. MIT Press.
- Stiegler, B. (2007). Anamnesis and Hypomnesis: Plato as the first thinker of the proletarianisation. [lecture]. *Thinking Media Aesthetics: the Emergence of a Research Field*. Oslo.

- Stiegler, B. (2010). Memory. In W. J. T. Mitchell & M. B. N. Hansen (Eds.), *Critical Terms for Media Studies* (pp. 64–87). University of Chicago Press.
- Suzuki, M., & Floreano, D. (2008). Enactive robot vision. *Adaptive Behavior*, 16(2-3), 122–128.
- The Fog System. (2011, August 4). THE FOG SYSTEM - Blur Expo'02 Arteplage Yverdon-les-bains [video]. Retrieved March 3, 2018, from <https://www.youtube.com/watch?v=l7-CG5f9eio>
- The Great Big Mirror Dome Project (1970). (1969). The Great Big Mirror Dome Project (1970). Retrieved from <http://www.bfi.org.uk/films-tv-people/4ce2b72139d5b>
- The Japan Institute of Architects Kanto-Koshinetsu Chapter (Ed.). (2010). JIA Bulletin 2010 / Colonnade. Retrieved March 5, 2018, from <http://www.jia-kanto.org/members/bulletin/2010/06annual/04.html>
- Togelius, J., Shaker, N., & Nelson, M. J. (2016). Grammars and L-systems with applications to vegetation and levels. In N. Shaker, J. Togelius, & M. J. Nelson (Eds.), *Procedural Content Generation in Games: A Textbook and an Overview of Current Research* (pp. 73–98). Springer.
- Toy, M. (Ed.). (1996). *Architectural Design: Architecture on the Horizon*. Academy Editions.
- Turing, A. M. (1950). Computing Machinery and Intelligence. *Mind*, 59(236), 433–460.
- Tzonis, A. (1999). Santiago Calatrava: The poetics of movement. Universe.
- UCLA Architecture. (2012). *Greg Lynn Profile: SUPRASTUDIO*. UCLA. Retrieved from [http://www.aud.ucla.edu/programs/m\\_arch\\_ii\\_degree\\_1/studios/2013\\_2014/lynn/?page\\_id=2](http://www.aud.ucla.edu/programs/m_arch_ii_degree_1/studios/2013_2014/lynn/?page_id=2)
- Van Nederveen, G. A., & Tolman, F. P. (1992). Modelling multiple views on buildings. *Automation in Construction*, 1(3), 215–224. [http://doi.org/10.1016/0926-5805\(92\)90014-B](http://doi.org/10.1016/0926-5805(92)90014-B)
- Van Schaik, L. (2008). *Spatial intelligence*. John Wiley and Sons.
- Varela, F. J., Thompson, E., & Rosch, E. (1992). *The embodied mind: Cognitive science and human experience*.
- Verbeke, J. (2013). This is Research By Design. In M. Fraser (Ed.), *Design Research in Architecture: An Overview* (p. 312). Ashgate Publishing, Ltd.
- Visser, B. (2015). *The End of Sitting 1:1 [Short film]*. (B. Visser, Ed.). Retrieved from <https://vimeo.com/123212930>
- Wannous, S. (2013, November 28). *Les économies d'énergie provoquées par la crise pétrolière de 1974 dans les bâtiments publics franciliens (PhD thesis)*. École Doctorale Abbé Grégoire, Paris.

- Ward, D., Silverman, D., & Villalobos, M. (2017). Introduction: The Varieties of Enactivism. *Topoi*, 36(3), 365–375. <http://doi.org/10.1007/s11245-017-9484-6>
- Waterhouse, L. (2006). Multiple Intelligences, the Mozart Effect, and Emotional Intelligence: A Critical Review. *Educational Psychologist*, 41(4), 207–225. [http://doi.org/10.1207/s15326985ep4104\\_1](http://doi.org/10.1207/s15326985ep4104_1)
- Weiser, M. (1996, March 17). Ubiquitous Computing. Retrieved October 26, 2017, from <http://www.ubiq.com/weiser/UbiHome.html>
- Wilson, M. D. (2002). Six views of embodied cognition. *Journal of Machine Learning Research*, 9(4), 625–636. <http://doi.org/10.3758/BF03196322>
- Wilson, R. A. (2004). *Boundaries of the mind: The individual in the fragile sciences*. Cambridge University Press.
- Wilson, R. A., & Foglia, L. (2016). Embodied Cognition. Retrieved October 26, 2016, from <http://plato.stanford.edu/archives/spr2016/entries/embodied-cognition/>
- Winfield, A. (2012). *Robotics: A Very Short Introduction* (Vol. 7). Oxford University Press.
- Winther, M. (2015). *Behaving Expressions: A Form Study of Shape-Changing Interfaces* (Master's thesis). IT University of Copenhagen.
- Wong, J. K. W., Li, H., & Wang, S. W. (2005). Intelligent building research: a review. *Automation in Construction*, 14(1), 143–159. <http://doi.org/10.1016/j.autcon.2004.06.001>
- Woodbury, R. (2010). *Elements of parametric design*. Taylor & Francis Group.
- Yang, D., Mosadegh, B., Ainla, A., Lee, B., Khashai, F., Suo, Z., et al. (2015). Buckling of Elastomeric Beams Enables Actuation of Soft Machines. *Advanced Materials*, 27(41), 6323–6327. <http://doi.org/10.1002/adma.201503188>
- Yiannoudes, S. (2016a). *Architecture and Adaptation: From Cybernetics to Tangible Computing*. Routledge.
- Yiannoudes, S. (2016b). Intelligence in Architectural Environments. In *Architecture and Adaptation: From Cybernetics to Tangible Computing*. Routledge.
- Zuk, W., & Clark, R. H. (1970). *Kinetic Architecture*. New York; London: Van Nostrand Reinhold.

# Figures

Unless otherwise noted, visual material is produced by the author of this work. The author gratefully acknowledges the permission granted to reproduce the copyright material in this dissertation. Every effort has been made to trace copyright holders and to obtain their permission for the use of copyright material. The author apologises for any errors or omissions in the list below.

- 1.1 Constant Nieuwenhuys, *Mobiel Ladder Labyrinth* (1967). Gielen, P., Romero, P. G., Stamps, L., Stokvis, W., Van der Horst, T., & Wigley, M. (2015). *Constant: New Babylon*. (M. Pineda, Ed.). MNCARS.
- 1.2 Jean Prouvé, Marcel Lods, Eugène Beaudouin, Vladimir Bodiensky; *Maison du Peuple in Clichy*. Simonot, B. (2010). *La Maison du Peuple de Clichy-la-Garenne*. Monografik Éditions.
- 1.3 Arata Isozaki, Deme and Deku performing robots. Davidson, C., & Lynn, G. (2017). *Log 36: Robolog*. Anyone Corporation.
- 1.4 soma, *One Ocean Pavilion*. <http://transsolar.com/projects/one-ocean-pavillon-expo-2012>
- 1.5 Next Office, *Sharifi-ha House*. <http://nextoffice.ir/#!/project/sharifi-ha-house/>
- 1.6 OMA, *Fondation d'Entreprise Galeries Lafayette*. Photograph by Delfino Sisto Legnani and Marco Cappelletti, Courtesy of OMA.
- 1.7 Lina Bo Bardi, *Cavaletes de Vidro* (glass easels). <http://fotografia.folha.uol.com.br/galerias/40419-cavaletes-de-vidro#foto-571235>
- 1.8 Damien Newman, *Design Squiggle*. Newman, D. (2008, July 20). *That Squiggle of the Design Process*. Retrieved April 6, 2018, from <https://web.archive.org/web/20081120061039/http://centralstory.com/filed/squiggle/>
- 1.9 *Triple Squiggle*.
- 2.1 PEIS Ecology. <https://www.youtube.com/watch?v=nV3YmoPoXJg>
- 2.2 McCulloch and Pitts' net of nervous activity. McCulloch, W. S., & Pitts, W. (1943). A logical calculus of the ideas immanent in nervous activity. *The Bulletin of Mathematical Biophysics*, 5(4), 115–133.
- 2.3 Cedric Price, *Generator Project*. <https://io.wp.com/www.interactivearchitecture.org/wp-content/uploads/2015/05/generator-project-white-cedric-price1978.jpg>
- 2.4 RAAAF and Barbara Visser, *The End of Sitting*. [http://www.raaaf.nl/nl/projects/927\\_the\\_end\\_of\\_sitting/](http://www.raaaf.nl/nl/projects/927_the_end_of_sitting/)
- 2.5 *Hyperbody, Muscle NSA*. <http://onl.eu/sites/default/files/portfolio-gallery-img/P1010082.jpg>
- 2.6 *Freeform Construction, Mineral Skin digital prototype*. Rupert, S., & David, A. (n.d.). *The Role of Additive Manufacturing and Physiometric Computational Design for Digital Construction*. *Architectural Design*, 82(2), 126–135. <http://doi.org/10.1002/ad.1389>

- 2.7 RAAAF and Barbara Visser, The End of Sitting. [http://www.raaaf.nl/nl/projects/927\\_the\\_end\\_of\\_sitting/](http://www.raaaf.nl/nl/projects/927_the_end_of_sitting/)
- 2.8 Shakey. <http://www.computerhistory.org/revolution/artificial-intelligence-robotics/13/289/1229>
- 2.9 Genghis. <http://www.ai.mit.edu/projects/genghis/genghis.jpg>
- 2.10 Charles Garnier, Opéra Garnier. Artwork Riquois, Engraving Jean-Joseph Sulpis. [https://commons.wikimedia.org/wiki/File:Palais\\_Garnier\\_Grand\\_Escalier\\_d%27Honneur\\_-\\_Garnier\\_1880\\_vol2\\_plate8.jpg](https://commons.wikimedia.org/wiki/File:Palais_Garnier_Grand_Escalier_d%27Honneur_-_Garnier_1880_vol2_plate8.jpg)
- 2.11 Basilica of Sainte-Marie-Madeleine in Vézelay. Photo Francis Vérillon. <https://commons.wikimedia.org/w/index.php?curid=4764418>
- 2.12 Le Corbusier, Villa Savoye. <http://www.daniellaondesign.com/blog/magical-staircases>
- 2.13 Walter Gropius, Bauhaus Building in Dessau. <https://www.bauhaus-dessau.de/en/architecture/bauhaus-building.html>
- 2.14 Zaha Hadid, The Hague Villas, Spiral House. [http://www.frac-centre.fr/gestion/public/upload/oeuvre/maxi/HADI\\_995\\_03\\_01.jpg](http://www.frac-centre.fr/gestion/public/upload/oeuvre/maxi/HADI_995_03_01.jpg)
- 2.15 ZHA, Tokyo Olympic Stadium proposal with retractable roof.
- 2.16 Frei Otto and Günther Behnisch, roof structure covering Olympiapark in Munich. Photo Maximilian Dörrbecker (Chumwa)[https://commons.wikimedia.org/wiki/File:München\\_-\\_Olympiapark\\_\(Luftbild\).jpg](https://commons.wikimedia.org/wiki/File:München_-_Olympiapark_(Luftbild).jpg)
- 2.17 Face tracking camera and parametric model at Smartgeometry 2009.
- 2.18 Jules Moloney, State Change. Moloney, J. (2011). Designing Kinetics for Architectural Facades: State Change. Taylor & Francis. p.146.
- 2.19 Baubotanik, Aussichtsturm am Lippeufer in Olfen, Germany. Photo Sebastian Becker <http://www.bureau-baubotanik.de/projekte/olfen/aussichtsturm>
- 2.20 Cantoni Crescenti, Túnel. Photo Cantoni Crescenti. <https://www.cantoni-crescenti.com.br/tunnel-about/>
- 2.21 AL\_A, MPavilion 2015.
- 2.22 OMA, Garage Museum of Contemporary Art. Image courtesy OMA.
- 2.23 Thomas Heatherwick, Rolling Bridge. Photo Loz Pycock. [https://commons.wikimedia.org/wiki/File:The\\_Rolling\\_Bridge\\_by\\_Thomas\\_Heatherwick,\\_Paddington\\_Basin2.jpg](https://commons.wikimedia.org/wiki/File:The_Rolling_Bridge_by_Thomas_Heatherwick,_Paddington_Basin2.jpg)
- 2.24 Enclosure of the Gran Telescopio Canarias on La Palma.

- 2.25 Paul Andreu, Charles-de-Gaulle airport, Terminal 1. Photo Paul Maurer <https://www.archdaily.com/806698/paul-andreu-i-would-only-take-on-a-project-if-the-ideas-were-mine-otherwise-i-am-not-intereste/>
- 2.26 Richard Rogers, Lloyd's of London. Photo Phogel. [https://commons.wikimedia.org/wiki/File:Inside\\_Lloyd%27s\\_of\\_London.jpg](https://commons.wikimedia.org/wiki/File:Inside_Lloyd%27s_of_London.jpg)
- 2.27 Santiago Calatrava, Ernstings Warehouse. <https://calatrava.com/projects/ernstings-warehouse-coesfeld.html>
- 2.28 Santiago Calatrava, Ernstings Warehouse. <https://calatrava.com/projects/ernstings-warehouse-coesfeld.html>
- 3.1 Santiago Calatrava, Kuwait Pavilion for Expo '92 in Seville. <https://calatrava.com/projects/kuwait-pavilion-sevilla.html>
- 3.2 Hyperbody, Muscle NSA. <http://onl.eu/sites/default/files/portfolio-gallery-img/164-031204-nsa-muscle.JPG>
- 3.3 Henrique Mindlin, Residence of George Hime in Petrópolis. <http://petropolismodernista.arq.br/2014/12/05/residencia-george-hime-arq-henrique-mindlin/>
- 3.4 Intermedia Lab at ITU. Photo Ole Kristensen. <http://intermedia.itu.dk>
- 3.5 Augmented Oculus Rift.
- 3.6 Virtual dynamic tunnel.
- 3.7 Cantini Crescenti, Túnel. Photo Cantoni Crescenti. <https://www.cantoni-crescenti.com.br/tunnel-about/>
- 3.8 Pendulum Constellation.
- 3.9 Pendulum Constellation.
- 3.10 Design for access road to IJmuiden aan Zee. <http://historie.bureausla.nl/ijmuiden-aan-zee/#/bureausla>
- 3.11 3D-printed soft actuator.
- 3.12 Sketch for mobile of concentric circles in ceiling.
- 3.13 Mobile of planks, forming a wall.
- 3.14 Plastic strip and Lego.
- 3.15 Flexible strips in Soft House, Hamburg. IBA Hamburg GmbH. (2013). Smart Material House | Soft House. Hamburg: IBA Hamburg GmbH. Retrieved from <https://www.iba-hamburg.de/en/themes-projects/the-building-exhibition-within-the-building-exhibition/smart-material-houses/soft-house/projekt/soft-house.html>
- 3.16 Single strip in Foamalux.
- 3.17 Simulated sequence of strip movements.
- 3.18 Strip end with tube protruding through rotary bearing.



- 3.19 Laminated strip.
- 3.20 Scale model 1:15 with opaque strips.
- 3.21 Scale model 1:15 with transparent strips.
- 3.22 Scale model 1:15 with transparent strips.
- 3.23 Scale model 1:15 with transparent strips.
- 3.24 Scale model 1:15 with transparent strips.
- 3.25 Assembly station in Intermedia Lab.
- 3.26 Mounting box frames to truss system.
- 3.27 Stack of turntables.
- 3.28 Turntable laser cutting pattern.
- 3.29 Overview of parts of the integrated box.
- 3.30 Box frame assembly.
- 3.31 Top plate before assembly.
- 3.32 Top plates installed.
- 3.33 Turntable assembly.
- 3.34 Turntable installation sequence.
- 3.35 Strip installation sequence.
- 3.36 Adjusting strip position and alignment.
- 3.37 Adjusting strip position and alignment.
- 3.38 Prototype in white (with protective film).
- 3.39 Prototype in white (with protective film).
- 3.40 Prototype in white (with protective film).
- 3.41 Removal of protective film.
- 3.42 Prototype after removal of protective film.
- 3.43 Prototype after removal of protective film.
- 3.44 Stepper motor (shown is NEMA 23).
- 3.45 Control diagram.
- 3.46 Port-side controller boards and motor drivers.
- 3.47 Graphical User Interface for motorised strip movements.
- 3.48 Screws placed to remember next step of installation process.
- 3.49 Post-its help distinguish individual strips.
- 3.50 Coloured base plates aid identification of port and starboard sides.
- 3.51 Notes written directly on the work in progress.

- 3.52 Marks left on building.
- 3.53 Laser cutting prototype components.
- 3.54 Shigeru Ban Architects, Naked House. Photo Hiroyuki Hirai.  
[http://www.shigerubanarchitects.com/works/2000\\_naked-house/](http://www.shigerubanarchitects.com/works/2000_naked-house/)
- 4.1 329 prepared dc-motors, cotton balls, toluene tank.  
Photography by Zimoun © <http://www.zimoun.net/2013-329.html>.
- 4.2 Zimoun in collaboration with Architect Hannes Zweifel,  
20 prepared dc-motors, 81 cardboard boxes 70x70x70cm.  
Photography by Zimoun © <http://www.zimoun.net/2014-20.html>.
- 4.3 Zimoun, 36 ventilators, 4.7m<sup>3</sup> packing chips. Photography by  
Zimoun © <http://www.zimoun.net/2014-36.html>.
- 4.4 Zimoun, 198 prepared dc-motors, wire isolated, cardboard  
boxes 30x30x8cm. Photography by Zimoun © <http://www.zimoun.net/2012-198.html>.
- 4.5 Ned Kahn, Project Lions. <https://norr.com/global/projects/debenhams-store-refurbishment-oxford-street-86>
- 4.6 Alexander Calder, Black Widow. Folha de S.Paulo <https://fotografia.folha.uol.com.br/galerias/16744-sede-paulista-do-iab#foto-284833>
- 4.7 329 prepared dc-motors, cotton balls, toluene tank.  
Photography by Zimoun © <http://www.zimoun.net/2013-329.html>.
- 4.8 329 prepared dc-motors, cotton balls, toluene tank.  
Photography by Zimoun © <http://www.zimoun.net/2013-329.html>.
- 4.9 329 prepared dc-motors, cotton balls, toluene tank.  
Photography by Zimoun © <http://www.zimoun.net/2013-329.html>.
- 4.10 329 prepared dc-motors, cotton balls, toluene tank.  
Photography by Zimoun © <http://www.zimoun.net/2013-329.html>.
- 4.11 Aegis Hyposurface. <http://transmaterial.net/aegis-hyposurface/>
- 4.12 Diller + Scofidio, Jump Cuts. Photo by Cesar Rubio. <https://dsrny.com>.
- 4.13 NOX, HtwoOexpo. Fresh water pavilion. HtwoOexpo,  
Interactive Museum. Neeltje Jans Island, Netherlands, 1997.  
Architect: NOX, Lars Spuybroek. Image © NOX/Lars Spuybroek
- 4.14 ONL, Salt Water Pavilion. <http://onl.eu/projects/salt-water-pavilion>
- 4.15 dECOi, Prothesite. Toy, M. (Ed.). (1996). Architectural Design:  
Architecture on the Horizon. Academy Editions.
- 4.16 Aegis Hyposurface. © Arup

- 4.17 Aegis Hyposurface. <http://hyposurface.org>
- 4.18 Aegis Hyposurface. <http://hyposurface.org>
- 4.19 Aegis Hyposurface. <http://hyposurface.org>
- 4.20 Aegis Hyposurface. <http://hyposurface.org>
- 4.21 Aegis Hyposurface. [http://archiv.ok-centrum.at/english/presse/cyberartso3\\_fotos.html](http://archiv.ok-centrum.at/english/presse/cyberartso3_fotos.html)
- 4.22 Barkow Leibinger, Kinetic Wall. [http://www.barkowleibinger.com/archive/view/kinetic\\_wall](http://www.barkowleibinger.com/archive/view/kinetic_wall)
- 4.23 Ruairi Glynn, Reciprocal Space. <http://www.interactivearchitecture.org/reciprocal-space-ruairi-glynn.html>
- 4.24 Asif Khan, MegaFaces. Photo Scott Eaton. <http://www.scott-eaton.com/2014/megafaces-at-the-sochi-olympics>
- 4.25 Aedas, Al-Bahr Towers. Photo Christian Richters. <https://www.designboom.com/architecture/aedas-clads-al-bahr-towers-with-dynamic-shading-device-02-13-2014/>
- 4.26 Aegis Hyposurface. <http://www.mediaarchitecture.org/aegis-hyposurface-kinetic-mediafassade/>
- 4.27 Aegis Hyposurface. <http://hyposurface.org>
- 4.28 Wacoal-Riccar Pavilion. <http://www.expo70-park.jp>
- 4.29 Wacoal-Riccar Pavilion. Majima, S. (n.d.). ワコール・リッカーマシン館 (Wacoal-Riccar Sewing Machine Pavilion), 603–616.
- 4.30 Wacoal-Riccar Pavilion. Majima, S. (n.d.). ワコール・リッカーマシン館 (Wacoal-Riccar Sewing Machine Pavilion), 603–616.
- 4.31 Wacoal-Riccar Pavilion. <http://www.expo70-park.jp>
- 4.32 Yajirobee, balancing toy. <https://carvingcommunity-dentouart.com/2016/02/25/金の字やじろべー-kin-character-balancing-toy/>
- 4.33 Wacoal-Riccar Pavilion. <http://www.expo70-park.jp>
- 4.34 Wacoal-Riccar Pavilion. Japan Association for the 1970 World Exposition. (2006). 公式記録映画 日本万国博 (Official Recording of the World Exhibition in Japan) [documentary video]. Geneon Entertainment. 40:42.
- 4.35 Revolving restaurant in Fernsehturm, Berlin. <https://event.tv-turm.de/en/premises/restaurant/>
- 4.36 OMA, MPavilion 2017. <http://oma.eu/projects/mpavilion>
- 4.37 Theo Jansen, Strandbeest Animaris Adulari. Exploratorium. (2016). Strandbeest: The Dream Machines of Theo Jansen with photography by Lena Herzog. Retrieved April 7, 2018, from [www.exploratorium.edu/strandbeest](http://www.exploratorium.edu/strandbeest)
- 4.38 AL\_A, MPavilion 2015.
- 4.39 Wacoal-Riccar Pavilion. Wacoal et Riccar Pavilion, Osaka. (1969). Architecture d'Aujourd'hui, 142, XXV.

- 4.40 Cantoni Crescenti, Solo. Photo Cantoni Crescenti. <https://www.cantoni-crescenti.com.br/solo/>
- 4.41 Wacoal-Riccar Pavilion. Nihon Bankoku Hakurankai Ky kai. (1972). Japan World Exposition, Osaka, 1970, official report (Vol. 1). Osaka: Commemorative Association for the Japan World Exposition (1970).
- 4.42 Maison à Bordeaux. By Hans Werlemann / Copyright OMA. <http://oma.eu/projects/maison-a-bordeaux>
- 4.43 Maison à Bordeaux. Copyright OMA. <http://oma.eu/projects/maison-a-bordeaux>
- 4.44 Maison à Bordeaux. By Hans Werlemann / Copyright OMA. <http://oma.eu/projects/maison-a-bordeaux>
- 4.45 Maison à Bordeaux. By Hans Werlemann / Copyright OMA. <http://oma.eu/projects/maison-a-bordeaux>
- 4.46 Maison à Bordeaux. By Hans Werlemann / Copyright OMA. <http://oma.eu/projects/maison-a-bordeaux>
- 4.47 Maison à Bordeaux. By Hans Werlemann / Copyright OMA. <http://oma.eu/projects/maison-a-bordeaux>
- 4.48 Vladimír Karfík, Bata Elevator Office. <http://world.bata.com/news/2014/truly-one-kind-batas-elevator-office/>
- 4.49 Maison à Bordeaux. By Hans Werlemann / Copyright OMA. <http://oma.eu/projects/maison-a-bordeaux>
- 4.50 OMA, Prada Transformer. Prada Transformer/OMA. <http://oma.eu/projects/prada-transformer>
- 4.51 OMA, Prada Transformer. Prada Transformer/OMA. <http://oma.eu/projects/prada-transformer>
- 4.52 OMA, Fondation d'Entreprise Galeries Lafayette. Copyright OMA. <http://oma.eu/projects/fondation-entreprise-galeries-lafayette>
- 4.53 OMA, Kunsthall. Copyright OMA. <http://oma.eu/projects/kunsthall>
- 4.54 Blur Building. Photo Beat Widmer. <https://dsrny.com/project/blur-building>
- 4.55 Blur Building. By Diller Scofidio + Renfro. <https://dsrny.com/project/blur-building>
- 4.56 Blur Building. By Diller Scofidio + Renfro. <https://dsrny.com/project/blur-building>
- 4.57 Blur Building. Photo Beat Widmer. <https://dsrny.com/project/blur-building>
- 4.58 Blur Building. Photo Beat Widmer. <https://dsrny.com/project/blur-building>
- 4.59 Blur Building. Photo Beat Widmer. <https://dsrny.com/project/blur-building>

- 4.60 High-pressure nozzle in test setup. Photo Beat Widmer. <https://dsrny.com/project/blur-building>
- 4.61 Blur Building. Photo Beat Widmer. <https://dsrny.com/project/blur-building>
- 4.62 Iguazu Falls.
- 4.63 Pepsi Pavilion. Schumacher, S. (2014). The 1970 Pepsi Pavilion in Osaka. Retrieved August 7, 2017, from <http://www.uncubemagazine.com/blog/13753251>
- 4.64 Blur Building. Photo Beat Widmer. <https://dsrny.com/project/blur-building>
- 4.65 Institut du Monde Arabe.
- 4.66 Central diaphragm closing. Bony, P. (1987). Les Diaphragmes de L'I.M.A. [documentary film]. Gresh Productions.
- 4.67 Institut du Monde Arabe.
- 4.68 Institut du Monde Arabe. Concours Pour L'Institut Du Monde Arabe, Paris. (1982). Concours Pour L'Institut Du Monde Arabe, Paris. Architecture d'Aujourd'hui, 219, 87.
- 4.69 Institut du Monde Arabe. Bony, P. (1987). Les Diaphragmes de L'I.M.A. [documentary film]. Gresh Productions.
- 4.70 Institut du Monde Arabe.
- 4.71 Institut du Monde Arabe.
- 4.72 Aedas, Al-Bahr Towers. Photo Arup / John Lyle.
- 4.73 Aedas, Al-Bahr Towers. Photo Arup.
- 4.74 Spazio elastico. Photo Peter Cox. Van Abbemuseum Eindhoven.
- 4.75 Gianni Colombo, Strutturazione pulsante. <http://www.archiviogiannicolombo.org/en/portfolio/strutturazione-pulsante/>
- 4.76 Gianni Colombo, Strutturazione pulsante. Museo del Novecento - restauratori e restauri in museo. (2014). Retrieved October 7, 2017, from <http://www.rrmusei.it/en/musei-e-opere/museo-del-novecento/>
- 4.77 Spazio elastico. Ehrmann, W. (Ed.). (1975). Gianni Colombo: Kinetische Objekte Strukturen und Räume. Städtisches Museum Leverkussen Schloß Morsbroich.
- 4.78 Spazio elastico. Ehrmann, W. (Ed.). (1975). Gianni Colombo: Kinetische Objekte Strukturen und Räume. Städtisches Museum Leverkussen Schloß Morsbroich.
- 4.79 Spazio elastico.
- 4.80 Spazio elastico. Ehrmann, W. (Ed.). (1975). Gianni Colombo: Kinetische Objekte Strukturen und Räume. Städtisches Museum Leverkussen Schloß Morsbroich.

- 4.81 Spazio elastico. Ehrmann, W. (Ed.). (1975). Gianni Colombo: Kinetische Objekte Strukturen und Räume. Städtisches Museum Leverkusen Schloß Morsbroich.
- 4.82 RV (Room Vehicle) House Prototype.
- 4.83 European Extremely Large Telescope (E-ELT). Photo ESO/L. Calçada. <https://www.eso.org/public/images/eso1225a/>
- 4.84 RV (Room Vehicle) House Prototype. Greg Lynn Form. The work in its physical and digital forms was acquired by SFMoMA in 2016. <http://glform.com/room-vehicle/>
- 4.85 RV (Room Vehicle) House Prototype. Greg Lynn Form. The work in its physical and digital forms was acquired by SFMoMA in 2016. <http://glform.com/room-vehicle/>
- 4.86 RV (Room Vehicle) House Prototype.
- 4.87 RV (Room Vehicle) House Prototype. Greg Lynn Form. The work in its physical and digital forms was acquired by SFMoMA in 2016. <http://glform.com/room-vehicle/>
- 4.88 Envir()nment.
- 4.89 Envir()nment.
- 4.90 Envir()nment.
- 4.91 Envir()nment.
- 4.92 Envir()nment.
- 4.93 Envir()nment.
- 4.94 Envir()nment.
- 4.95 Envir()nment.
- 4.96 Modes of coupling.
- 4.97 West 8, Schouwburgplein. Photo Jeroen Musch. [http://www.west8.com/projects/civic\\_spaces/schouwburgplein/](http://www.west8.com/projects/civic_spaces/schouwburgplein/)
- 4.98 Envir()nment.
- 4.99 Gerrit Rietveld, Rietveld Schröder House. Photo Ton van der Wal. <http://rijksmonumenten.nl/monument/18329/rietveld-schraderhuis/utrecht/>
- 5.1 Richard Serra, Railroad Turnbridge. Krauss, R. E. (1985). The Originality of the Avant-garde and Other Modernist Myths. MIT Press. p.271.
- 5.2 Greg Lynn, Room Vehicle.
- 5.3 Pascal Bony, Les Diaphragmes de L'I.M.A. Bony, P. (1987). Les Diaphragmes de L'I.M.A. [documentary film]. Gresh Productions.
- 5.4 Mediated coupling in field of agency.

# Acknowledgements

Directly after the defence of my master's thesis in Delft, my supervisor suggested to do a PhD with him. Because I had already started a job at Arup, I had to decline the offer. Even though working for Arup had been a dream come true, a sense of regret about turning down the PhD never went away. When I ran into Kjell at the Smartgeometry conference of 2013, the possibility of doing a PhD became real. He knew a way to make it work. In the same year, Imke and I moved to Copenhagen.

The support from Arup, both financially and organisationally, was a crucial factor. Thanks go out to Tristram Carfrae, Peter Young, John Lyle, Jan Wurm, Chris Gibbons, and more recently David Gerber.

Thank you to all the interviewees for their time and insights, and Alexander Dimai at Dottikon ES for the warm welcome during my visit.

I would also like to thank my midway evaluation panelists Kasper Støy and Emilie Møllenbach for their critical questions and advice. With sadness I learned of the death of Johan Verbeke in 2017. Johan was one of the protagonists of research in design and arts, and was part of my midway evaluation panel.

At ITU I want to thank the PhD school for their support, FM for their constructive attitude, and the IT department for assistance. Especially Hassan, who helped me out when my laptop crashed two weeks before hand-in.

Thanks go out further to Ole Kristensen, who led the Intermedia Lab with an intelligent nonchalance that made it such a wonderful place to work. Cameline, my direct PhD colleague, for the discussions we had, especially at the beginning of our journeys, and for alignment later in the process. Jonas, for being such a wonderful and forgiving office mate and for the wonderful job of translating the abstract. Helen Dyrbye for your humour, patience, and of course for all your suggestions.

And of course Kjell, for taking me on this exciting journey and for your relentless questioning.





